

K A P P A<sup>®</sup>

100.9w

120.9w

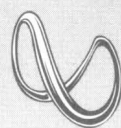

Infinity

# K A P P A

**THANK YOU** for choosing an Infinity® Kappa® Series 100.9w or 120.9w subwoofer. These Kappa subwoofers are designed to suit a broad range of car audio applications and can be used in a wide variety of enclosure types to produce extended, powerful bass in a limited amount of vehicle space. To get the most performance from your new subwoofer, it is strongly recommended that you have a qualified professional install your 100.9w or 120.9w subwoofer. Although this manual does provide general instructions about installing these Kappa Series subwoofers, it does not include enclosure construction details or exact installation methods for any particular vehicle. If you do not feel that you have the necessary experience, do not attempt the installation yourself, but instead ask your authorized Infinity dealer about professional installation options.

Remember to keep your sales receipt in a safe place, along with this manual, so that both are available for future reference.

## BOX CONTENTS

- (1) 100.9w or 120.9w subwoofer
- (1) Foam mounting gasket
- (1) 3mm hex wrench
- (1) Owner's manual
- (1) Technical data sheet

## WARNING

Playing loud music in a vehicle can hinder your ability to hear traffic and permanently damage your hearing. The maximum volume levels achievable by Infinity speakers when combined with high-power amplification may exceed safe levels for extended listening. Using low volume levels is recommended when driving. Infinity Systems accepts no liability for hearing loss, bodily injury, or property damage as a result of use or misuse of this product.

## REPRODUCING BASS IN VEHICLES

Depending on the size of your vehicle's interior listening space, reproduced bass frequencies below 80Hz will be boosted by nearly 12dB per octave as frequency decreases. This phenomenon, known as the vehicle's transfer function (or cabin gain), plays an important role in shaping the subwoofer's frequency response in your vehicle. The enclosed technical data sheet includes frequency response graphs that show both the subwoofer's "in-car" response (which factors in this vehicle transfer function) and its "out-of-car" response (which does not).

## SUBWOOFER ENCLOSURE TYPES

Kappa 100.9w and 120.9w subwoofers are designed to perform best in moderately sized sealed enclosures, vented enclosures and prefabricated band-pass enclosures. Infinite-baffle mounting is possible, but the subwoofer's mechanical power handling will be reduced because there will be no volume of air to stiffen the subwoofer's suspension and prevent overexcursion. If you choose infinite-baffle mounting, consider the RMS and peak power-handling ratings to be half of what is listed in the specifications in this manual.

You should choose an enclosure type based on the amount of cargo space you can devote to the enclosure, the amount of power you will use to drive your subwoofer(s), and your listening habits.

## SEALED ENCLOSURES

The air trapped inside a sealed enclosure is compressed when the subwoofer moves rearward and is rarefied when the subwoofer moves forward. In both cases, the air inside and outside the box will seek equilibrium by pushing and pulling on the subwoofer cone. The result is a stiffer suspension when compared to the subwoofer operating in free air. This means that the subwoofer's cone will be harder to move at low frequencies, a condition which protects the subwoofer from physical overexcursion, but requires more power than other designs to achieve a given acoustic output.



See accompanying data sheet for specific enclosure dimension requirements.

## SEALED-ENCLOSURE PERFORMANCE ADVANTAGES

- The in-vehicle performance will have the flattest overall frequency response.
- The in-vehicle response will have the widest bandwidth. (Usable low-frequency response inside the vehicle will be below 20Hz.)
- An optimum sealed enclosure will always be smaller than an optimum enclosure of another type.

## SEALED-ENCLOSURE PERFORMANCE TRADE-OFFS

- An optimum sealed enclosure will have lower overall efficiency than an optimum enclosure of another type.
- A 100.9w or 120.9w subwoofer in an optimum sealed enclosure will require more amplifier power to achieve a given acoustic output than in an optimum enclosure of another type.

## SEALED-ENCLOSURE CONSTRUCTION

Sealed-enclosure construction is straightforward and forgiving of errors in volume calculation, but air leaks should be avoided. Use medium-density fiberboard (MDF), glue and screws to construct the enclosure, and seal all joints with silicone caulk.

## THE INFINITY RECOMMENDATION

100.9w and 120.9w subwoofers in sealed enclosures are recommended for enthusiasts who prefer accurate music reproduction and flat frequency response, for those who have a smaller space to devote to a subwoofer enclosure, and for those who have plenty of amplifier power devoted to driving the subwoofer. The sealed-enclosure design indicated on the technical data sheet accompanying this manual represents the best compromise between low-frequency extension and flat response.

## VENTED ENCLOSURES

A vented enclosure acts like a sealed enclosure at frequencies above its tuned (resonance) frequency. At resonance (which is defined by the vent), the vent produces the majority of sound – the subwoofer cone is nearly stationary while the air inside the vent vibrates. This provides greater mechanical power handling at and above resonance, but reduced mechanical power handling below resonance. Since the subwoofer cone and voice coil don't move much at resonance, airflow across the voice coil is minimized and thermal power handling is reduced slightly at resonance.

Vented enclosures provide better efficiency in the 40Hz – 60Hz range, at the expense of sound output in the lowest octave (below 40Hz). The use of an infrasonic filter is recommended with vented enclosures. An optimum vented enclosure for a Kappa Series subwoofer is larger than an optimum sealed enclosure.



See accompanying data sheet for specific enclosure dimension requirements.

## VENTED-ENCLOSURE PERFORMANCE ADVANTAGES

- An optimum vented enclosure has greater efficiency and higher output in the 40Hz – 60Hz range than an optimum sealed enclosure.
- An optimum vented enclosure provides a greater sensation of bass than an optimum sealed enclosure.
- A 100.9w or 120.9w subwoofer in an optimum vented enclosure will require less amplifier power to achieve a given acoustic output (down to the enclosure's resonance frequency) than in an optimum sealed enclosure.

## VENTED-ENCLOSURE PERFORMANCE TRADE-OFFS

- Reduced output in the lowest octave (below 40Hz).
- Reduced mechanical power handling below the enclosure's resonance frequency. The use of an electronic infrasonic filter is strongly recommended, to reduce the chance of overdriving the subwoofer below the enclosure's resonance frequency.
- An optimum vented enclosure will always be larger than an optimum sealed enclosure.

## VENTED-ENCLOSURE CONSTRUCTION

Vented-enclosure construction is more difficult than the construction of a sealed enclosure. The enclosure volume and port dimensions have a specific relationship with the physical and electromechanical characteristics of the subwoofer, requiring that the recommended enclosure volume and port characteristics be strictly observed. As with sealed enclosures, use medium-density fiberboard (MDF), glue and screws to construct the enclosure, and seal all joints with silicone caulk.

## THE INFINITY RECOMMENDATION

100.9w and 120.9w subwoofers in vented enclosures are recommended for enthusiasts who prefer accentuated bass response, for those who have plenty of cargo space to devote to a subwoofer enclosure and for those who will use a less powerful amplifier to drive their subwoofer. The volume and port dimensions indicated on the included technical data sheet must be followed precisely to ensure optimum performance.

## BAND-PASS ENCLOSURES

Band-pass enclosures can provide the most output from any amplifier and subwoofer combination over a limited band of frequencies, but that additional output comes at the expense of sonic accuracy. Band-pass enclosures combine a sealed or vented enclosure that houses the subwoofer along with a vented chamber into which the subwoofer outputs its sound. The vented chamber acts as an acoustic low-pass filter which attenuates high frequencies in the subwoofer's output. That attenuation of high frequencies can make it very difficult to hear amplifier and speaker distortion; consequently, you may not be able to determine when the subwoofer is in danger of being damaged.

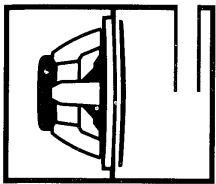

See accompanying data sheet for specific enclosure dimension requirements.

## BAND-PASS-ENCLOSURE PERFORMANCE ADVANTAGES

- An optimum band-pass enclosure provides higher output over a limited bandwidth than an optimum enclosure of any other type.

## BAND-PASS-ENCLOSURE PERFORMANCE TRADE-OFFS

- Band-pass enclosures achieve high output at the expense of sonic accuracy.
- An optimum band-pass enclosure has a more limited bandwidth than an optimum enclosure of any other type.
- The enclosure's low-pass filter characteristics can make it difficult to hear if the subwoofer is in danger of being damaged.
- An optimum band-pass enclosure is usually larger than an optimum vented enclosure.

## BAND-PASS-ENCLOSURE CONSTRUCTION

Band-pass-enclosure construction is more difficult than vented-box construction and, as with vented enclosures, the design parameters for the vented section must be followed carefully. (The sealed section is more forgiving of small design and construction variations.) Fortunately, there are many prefabricated band-pass enclosures that are designed to extract the most output possible from nearly any subwoofer. Prefabricated band-pass enclosures are strongly recommended if you must have a band-pass enclosure. If you choose to build your own band-pass enclosure, use medium-density fiberboard (MDF), glue and screws to construct the enclosure, and be sure to seal all joints with silicone caulk.

## THE INFINITY RECOMMENDATION

Band-pass enclosures are recommended only for enthusiasts who want high sound-pressure levels (SPL) without regard for sonic accuracy. If high SPL AND great-sounding bass are your goals, choosing a vented enclosure is recommended instead.

# K A P F A

## MOUNTING THE SUBWOOFER

The 100.9w and 120.9w subwoofers can be mounted from the outside of the enclosure or from the inside of the enclosure. Whichever way you mount the subwoofer, use the included foam mounting gasket to ensure a leak-free seal between the subwoofer frame and the enclosure.

## CONNECTING THE SUBWOOFER

### SETTING THE IMPEDANCE

The 100.9w and 120.9w subwoofers both feature the Selectable Smart Impedance™ (SSI) switch. This exclusive feature lets you set the subwoofer's impedance to either 2 ohms or 4 ohms with the flip of a switch (see illustrations to the right). This allows you to extract the most from your subwoofer amplifier in any situation.

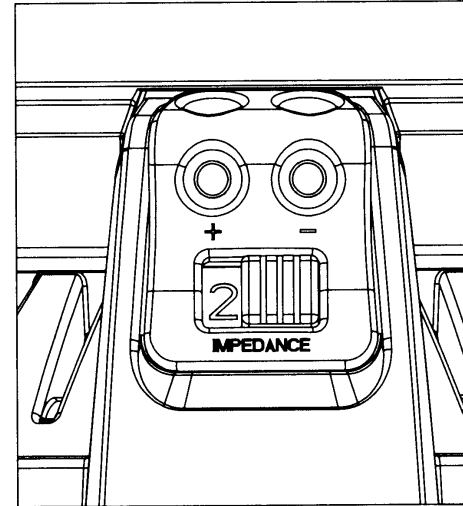

2-Ohm Setting

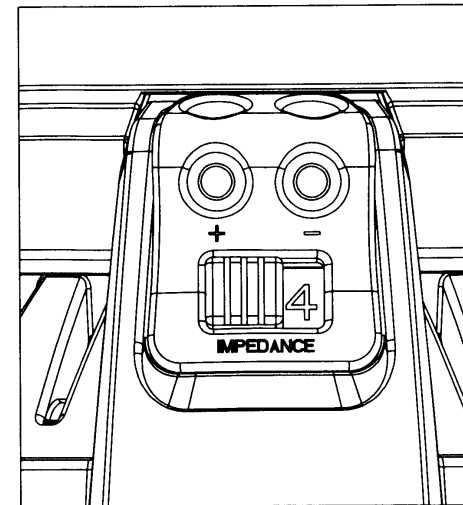

4-Ohm Setting

The SSI 2-ohm setting increases the subwoofer's output over the 4-ohm setting by up to 3dB, depending on the amplifier. Performance is identical in all other respects. If the connected amplifier is rated for 2-ohm operation and its 2-ohm power ratings are within the subwoofer's power-handling specifications, setting the SSI switch in the 2-ohm position will achieve maximum output.

**IMPORTANT:** Make sure the subwoofer amplifier is turned OFF before setting the SSI switch. Do not change the switch position while the subwoofer amplifier is operating. Doing so could damage the amplifier.

## CONNECTING THE AMPLIFIER

The Kappa 100.9w and 120.9w subwoofer connectors are compatible with bare wire up to 8 AWG (tinned or untinned) and wire that is terminated with pin connectors. Although single banana connectors will fit into the connector openings, the connection may not be secure.

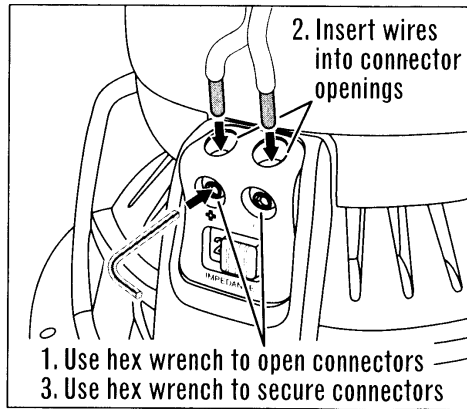

1. Use the included 3mm hex wrench to open the connectors, as shown in the illustration to the left.

2. Insert the wire ends into the connector openings, as shown in the illustration to the left.

**NOTE:** If using untinned bare wire, be sure that no stray “+” and “-” strands touch each other. Touching strands can cause a short-circuit, which can damage your amplifier.

3. Use the hex wrench to secure the wires in the connectors, as shown in the illustration to the left.

## SPECIFICATIONS

	100.9w 10" (250mm) SSI Automotive Subwoofer	120.9w 12" (300mm) SSI Automotive Subwoofer
Power Handling (RMS):	350W	350W
Power Handling (Peak):	1400W	1400W
Sensitivity @ 2.83V/1m:	89dB	91dB
Frequency Response:	25Hz – 400Hz	23Hz – 400Hz
Impedance:	2 or 4 ohms (selectable)	2 or 4 ohms (selectable)
Voice-Coil Diameter:	2" (50mm)	2" (50mm)
Mounting Depth:	5-15/16" (150mm)	6-5/16" (160mm)
Overall Diameter:	10-3/4" (273mm)	12-5/8" (320mm)
Cutout Diameter:	9-1/4" (234mm)	11-3/16" (283mm)

A valid serial number is required for warranty coverage.

Features, specifications and appearance are subject to change without notice.

These products are designed for mobile applications and are not intended for connection to the mains.

Harman Consumer Group, Inc., 8500 Balboa Blvd., Northridge, CA 91329 USA

[www.infinitysystems.com](http://www.infinitysystems.com)

© 2009 Harman International Industries, Incorporated. All rights reserved. • Part No. REF100.9 120.9SUBOM 3 09  
Infinity and Kappa are trademarks of Harman International Industries, Incorporated, registered in the United States and/or other countries.

**H** Harman International



### Declaration of Conformity



We, Harman Consumer Group, Inc.  
2, route de Tours  
72500 Château du Loir  
France

declare in own responsibility that the products described  
in this owner's manual are in compliance with technical  
standards:

EN 61000-6-3:2001

EN 61000-6-1:2001

Klaus Lebherz  
Harman Consumer Group, Inc.  
Château du Loir, France 3/09





# KAPPA® 100.9W 10" WOOFER — TECHNICAL DATA



## THIELE-SMALL PARAMETERS

	2Ω	4Ω
VOICE-COIL DC RESISTANCE:	$R_{EVC}$ (OHMS) . . . . . 2.00	4.20
VOICE-COIL INDUCTANCE @ 1kHz:	$L_{EVC}$ (MH) . . . . . 1.17	1.17
DRIVER RADIATING AREA:	$S_D$ (IN <sup>2</sup> ) . . . . . 51.20	51.20
	$S_D$ (M <sup>2</sup> ) . . . . . 330.00	330.00
MOTOR FORCE FACTOR:	$BL$ (TM) . . . . . 12.47	17.72
COMPLIANCE VOLUME:	$V_{AS}$ (FT <sup>3</sup> ) . . . . . 0.64	0.64
	$V_{AS}$ (LITERS) . . . . . 18.05	18.05
SUSPENSION COMPLIANCE:	$C_{MS}$ (µM/N) . . . . . 118.00	118.00
MOVING MASS, AIR LOAD:	$M_{MS}$ (GRAMS) . . . . . 188.00	188.00
FREE-AIR RESONANCE:	$F_S$ (Hz) . . . . . 33.80	33.80
MECHANICAL Q:	$Q_{MS}$ . . . . . 4.18	2.43
ELECTRICAL Q:	$Q_{ES}$ . . . . . 0.51	0.53
TOTAL Q:	$Q_{TS}$ . . . . . 0.46	0.44
MAGNETIC-GAP HEIGHT:	$H_{AG}$ (IN) . . . . . 0.39	0.39
	$H_{AG}$ (MM) . . . . . 10.00	10.00
VOICE-COIL HEIGHT:	$H_{VC}$ (IN) . . . . . 1.57	1.57
	$H_{VC}$ (MM) . . . . . 40.00	40.00
MAXIMUM EXCURSION:	$X_{MAX}$ (IN) . . . . . 0.68	0.68
	$X_{MAX}$ (MM) . . . . . 17.50	17.50

## SPECIFICATIONS

DIAMETER:	10" (254mm)
SENSITIVITY (2.83V @ 1m):	89dB
POWER HANDLING:	350W <sub>RMS</sub> (1400W <sub>PEAK</sub> )
FREQUENCY RESPONSE:	25Hz ~ 400Hz
NOMINAL IMPEDANCE:	2 OR 4 OHMS
VOICE-COIL DIAMETER:	2" (51mm)
DIMENSIONS:	

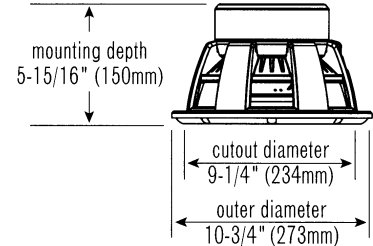

## SEALED-BOX VOLUME (INCLUDES DRIVER DISPLACEMENT)

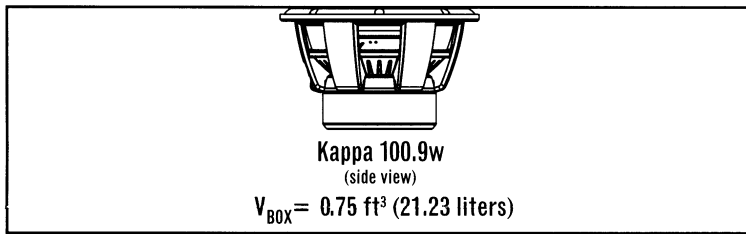

## SEALED ENCLOSURE (FREQUENCY RESPONSE @ 2.83V)

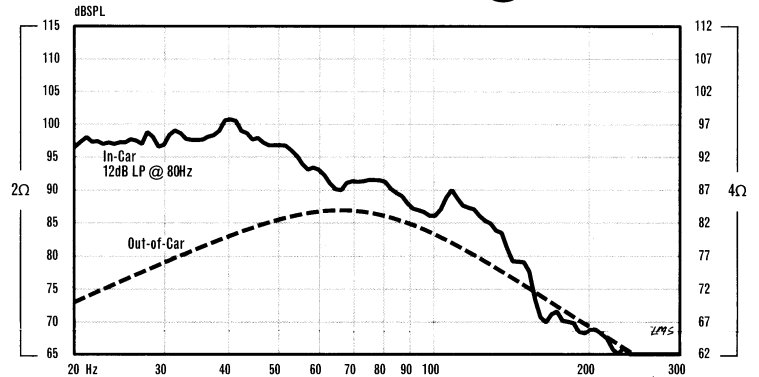

## VENTED-BOX VOLUME (INCLUDES DRIVER/PORT DISPLACEMENTS)

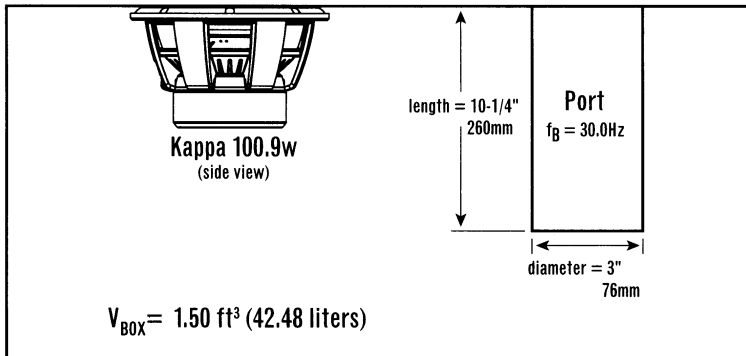

## VENTED ENCLOSURE (FREQUENCY RESPONSE @ 2.83V)

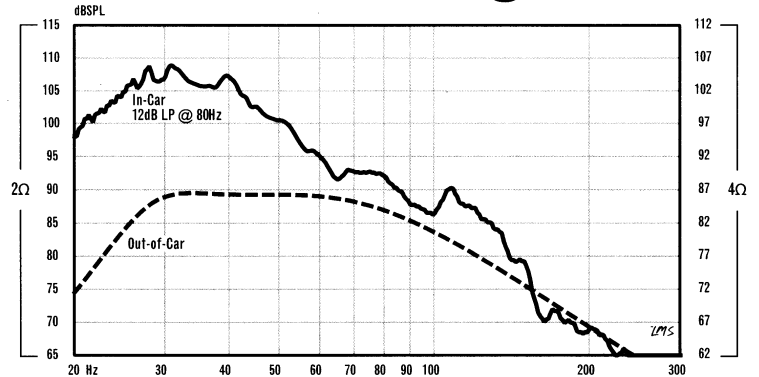

## BAND-PASS-BOX VOLUME (INCLUDES DRIVER/PORT DISPLACEMENTS)

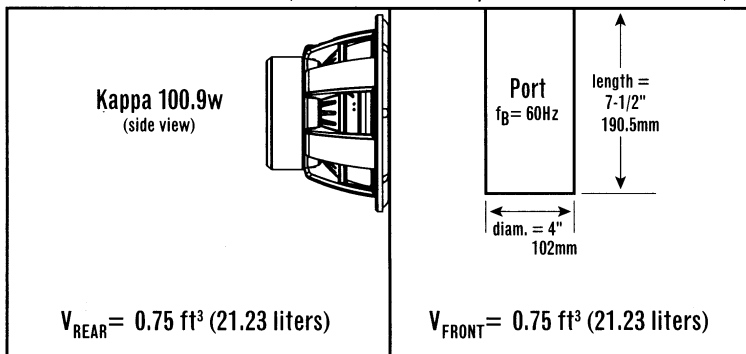

## BAND-PASS ENCLOSURE (FREQUENCY RESPONSE @ 2.83V)

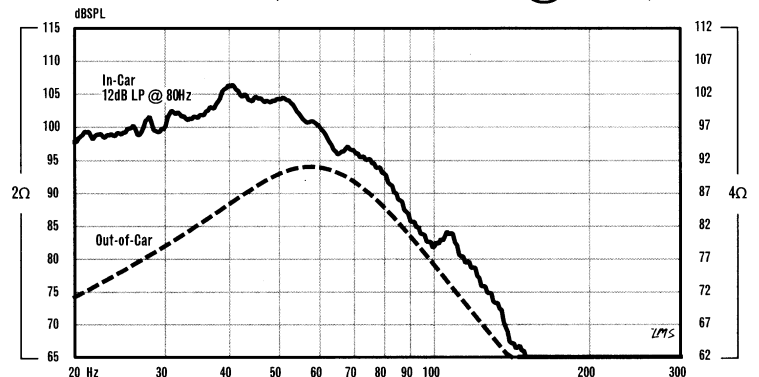

# KAPPA® 120.9W 12" WOOFER — TECHNICAL DATA



## THIELE-SMALL PARAMETERS

	2Ω	4Ω
VOICE-COIL DC RESISTANCE:	$R_{EVC}$ (OHMS) . . . . . 2.10 . . . . . 4.30	
VOICE-COIL INDUCTANCE @ 1kHz:	$L_{EVC}$ (MH) . . . . . 1.18 . . . . . 1.18	
DRIVER RADIATING AREA:	$S_D$ (IN <sup>2</sup> ) . . . . . 80.40 . . . . . 80.40	
	$S_D$ (M <sup>2</sup> ) . . . . . 518.80 . . . . . 518.80	
MOTOR FORCE FACTOR:	$BL$ (TM) . . . . . 12.87 . . . . . 18.37	
COMPLIANCE VOLUME:	$V_{AS}$ (FT <sup>3</sup> ) . . . . . 1.92 . . . . . 1.92	
	$V_{AS}$ (LITERS) . . . . . 54.43 . . . . . 54.43	
SUSPENSION COMPLIANCE:	$C_{MS}$ (μM/N) . . . . . 144.00 . . . . . 144.00	
MOVING MASS, AIR LOAD:	$M_{MS}$ (GRAMS) . . . . . 237.00 . . . . . 237.00	
FREE-AIR RESONANCE:	$F_S$ (Hz) . . . . . 27.20 . . . . . 27.20	
MECHANICAL Q:	$Q_{MS}$ . . . . . 4.38 . . . . . 2.47	
ELECTRICAL Q:	$Q_{ES}$ . . . . . 0.51 . . . . . 0.52	
TOTAL Q:	$Q_{TS}$ . . . . . 0.46 . . . . . 0.43	
MAGNETIC-GAP HEIGHT:	$H_{AG}$ (IN) . . . . . 0.39 . . . . . 0.39	
	$H_{AG}$ (MM) . . . . . 10.00 . . . . . 10.00	
VOICE-COIL HEIGHT:	$H_{VC}$ (IN) . . . . . 1.57 . . . . . 1.57	
	$H_{VC}$ (MM) . . . . . 40.00 . . . . . 40.00	
MAXIMUM EXCURSION:	$X_{MAX}$ (IN) . . . . . 0.68 . . . . . 0.68	
	$X_{MAX}$ (MM) . . . . . 17.50 . . . . . 17.50	

## SPECIFICATIONS

DIAMETER:	12" (305mm)
SENSITIVITY (2.83V @ 1m):	91dB
POWER HANDLING:	350W <sub>RMS</sub> (1400W <sub>PEAK</sub> )
FREQUENCY RESPONSE:	23Hz ~ 400Hz
NOMINAL IMPEDANCE:	2 OR 4 OHMS
VOICE-COIL DIAMETER:	2" (51mm)

### DIMENSIONS:

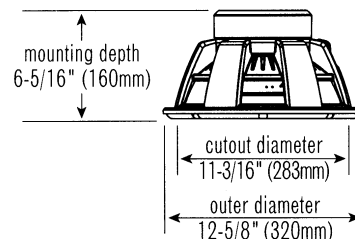

## SEALED-BOX VOLUME (INCLUDES DRIVER DISPLACEMENT)

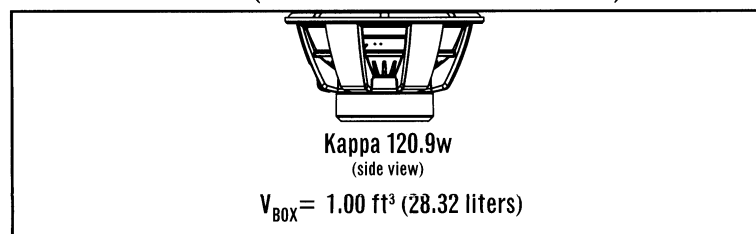

## SEALED ENCLOSURE (FREQUENCY RESPONSE @ 2.83V)

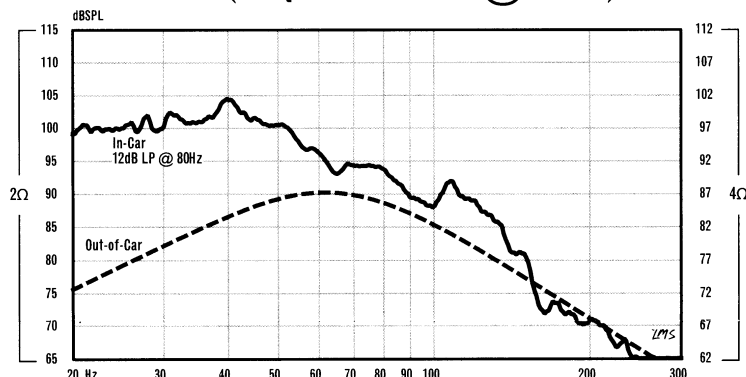

## VENTED-BOX VOLUME (INCLUDES DRIVER/PORT DISPLACEMENTS)

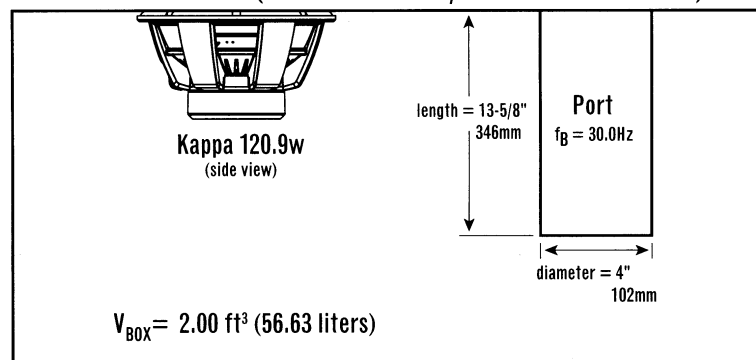

## VENTED ENCLOSURE (FREQUENCY RESPONSE @ 2.83V)

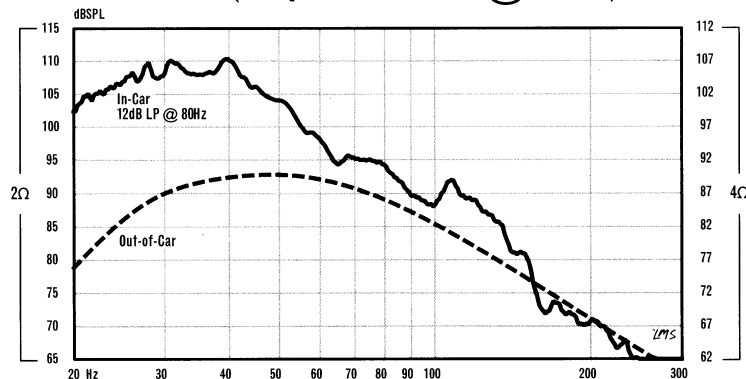

## BAND-PASS-BOX VOLUME (INCLUDES DRIVER/PORT DISPLACEMENTS)

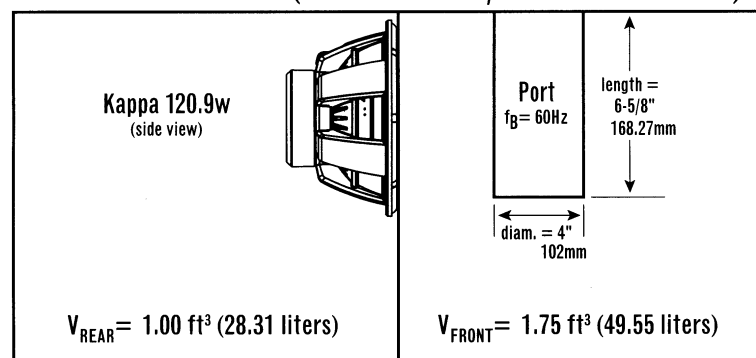

## BAND-PASS ENCLOSURE (FREQUENCY RESPONSE @ 2.83V)

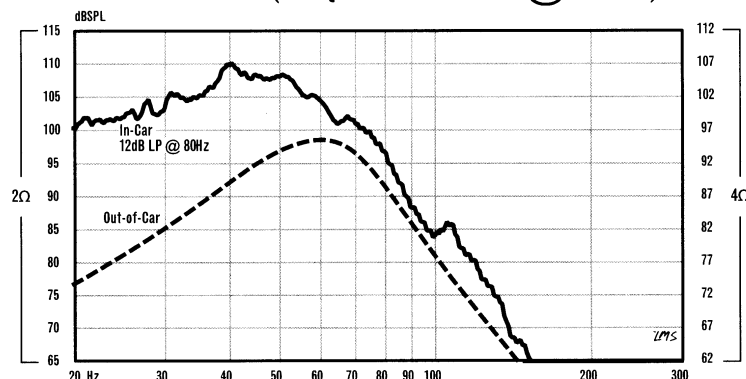

# We need to hear from you!

- Warranty Service
- Confirmation of Ownership

In the world of high fidelity, technology is all too often viewed as the end product. At Infinity®, we have a different viewpoint: technology is only the means to an end. The end result must be enjoyment of the programs and music you hear.



**Thanks for choosing Infinity**

Register your purchase via the Internet at:

<http://www.infinitysystems.com>

Click on "Product Support"

Click on "Owner's Registration"

# LIMITED THREE-YEAR WARRANTY

## Infinity Kappa® and Kappa Perfect (applies to USA only)

### A valid serial number is required for warranty coverage.

#### WHO IS PROTECTED BY THIS WARRANTY?

Your Infinity warranty protects the original owner and all subsequent owners for a period of three (3) years (parts and labor) for all loudspeaker and/or electronic components from any failure as a result of an original manufacturing defect so long as: (1) your Infinity product was originally purchased within the fifty United States or by military personnel from an authorized military outlet, (2) the dealer from whom the product was purchased was authorized by Infinity to sell such products at the time of original purchase and (3) the original, dated Bill of Sale is presented whenever service is required during the warranty period. This warranty is only valid for service within the United States and does not apply to products purchased elsewhere; other purchasers should contact their local Infinity distributor for warranty information.

#### WHAT DOES THE INFINITY WARRANTY COVER?

Except as specified below, this warranty covers all defects in original materials and workmanship. The following are not covered: damage caused by accident, misuse, abuse, neglect, product modification; damage occurring during shipment; damage caused by failure to follow instructions in the owner's guide, including failure to perform recommended periodic or routine maintenance; damage resulting from repairs by someone not authorized by Infinity; units used for other than car use; units not used for their intended purpose; claims based upon any misrepresentations by the seller; and any Infinity product on which the serial number has been altered, defaced or removed.

**NOTE:** Repair of our products must be done by an authorized dealer or service center. **Unauthorized repair will void the warranty and is done at the risk of the consumer.**

#### WHO PAYS FOR WHAT?

During the period of this warranty, subject to the above conditions, Infinity will pay all of the labor and material expenses to repair a warrantable defect.

#### HOW CAN WARRANTY SERVICE BE OBTAINED?

In the event that your Infinity product(s) should require service, you should first contact either the Infinity dealer from whom the product was purchased or an authorized service center. For the name of an Infinity service center, visit our Web site at [www.infinitysystems.com](http://www.infinitysystems.com), write us directly at Infinity (ATTN: Customer Service), 250 Crossways Park Drive,

Woodbury, NY 11797, or call 516.674.4INF (4463). We may direct you to an authorized service center for Infinity products or ask you to send the product to us for repair. In either case, you will have to present your original Bill of Sale to establish warranty coverage. Do not send your product to us without prior authorization from our Customer Service Department. You are responsible for transporting your product to either Infinity or an authorized service center and for payment of all shipping charges; however, Infinity will pay the return shipping charges (in the event you return the product to us) if the repairs are covered by warranty. If you experience difficulty in transporting your product or are in need of packing materials, please advise us and we may be able to suggest alternative procedures and/or provide adequate packing materials.

**LIMITATION OF IMPLIED WARRANTIES:** All implied warranties, including fitness for a particular purpose and merchantability, are limited in duration and length to the warranty period for your product.

**LIMITATION OF INCIDENTAL OR CONSEQUENTIAL DAMAGES:** Infinity is not responsible for incidental or consequential damage of any kind. Our liability is limited to the repair or replacement, at our option, of a defective product.

Some states do not allow limitations on how long an implied warranty lasts and/or do not allow the exclusion of incidental or consequential damages, so the above limitations or exclusions may not apply to you. This warranty gives you specific legal rights and you may also have other rights, which vary, from state to state.

**NOTE:** In the event that there is a difference between this warranty and the provisions in any advertisements, product brochure or packaging cartons, the terms of this warranty will prevail.

Infinity continually strives to update and improve existing products, as well as create new ones. The specifications and construction details in this and related Infinity publications are, therefore, subject to change without notice.

© 2003 Harman International Industries, Incorporated. P/N: KAP3-YRWTY REV. 9/03  
Infinity Systems, 250 Crossways Park Drive, Woodbury, NY 11797 USA 516.674.4INF (4463)

**H** A Harman International Company

Infinity is a registered trademark of Harman International Industries, Incorporated.

#### PLEASE MAKE NOTE OF THE FOLLOWING INFORMATION AND RETAIN FOR YOUR RECORDS

Product Name: \_\_\_\_\_ Model Number: \_\_\_\_\_

Store Name: \_\_\_\_\_ Date of Purchase: \_\_\_\_\_