



- Indian Railways
Whistling Ahead

Story of Growth & Modernisation



Electrical Department

CONTENTS

| | | |
|--------------------|---|----|
| Chapter - 1 | Rail History - Indian Railways - Way of Life | 01 |
| Chapter - 2 | Rail Electrification | 04 |
| Chapter - 3 | Locomotives & EMUs | 15 |
| Chapter - 4 | Efficient use of Energy in Indian Railways and its Energy Conservation Initiatives | 47 |
| Chapter - 5 | The New Paradigm of Electric Power Procurement | 59 |
| Chapter - 6 | Decarbonization of IR's Energy Needs - Power through Wind & Solar Plants | 66 |
| Chapter - 7 | Future Initiative | 72 |

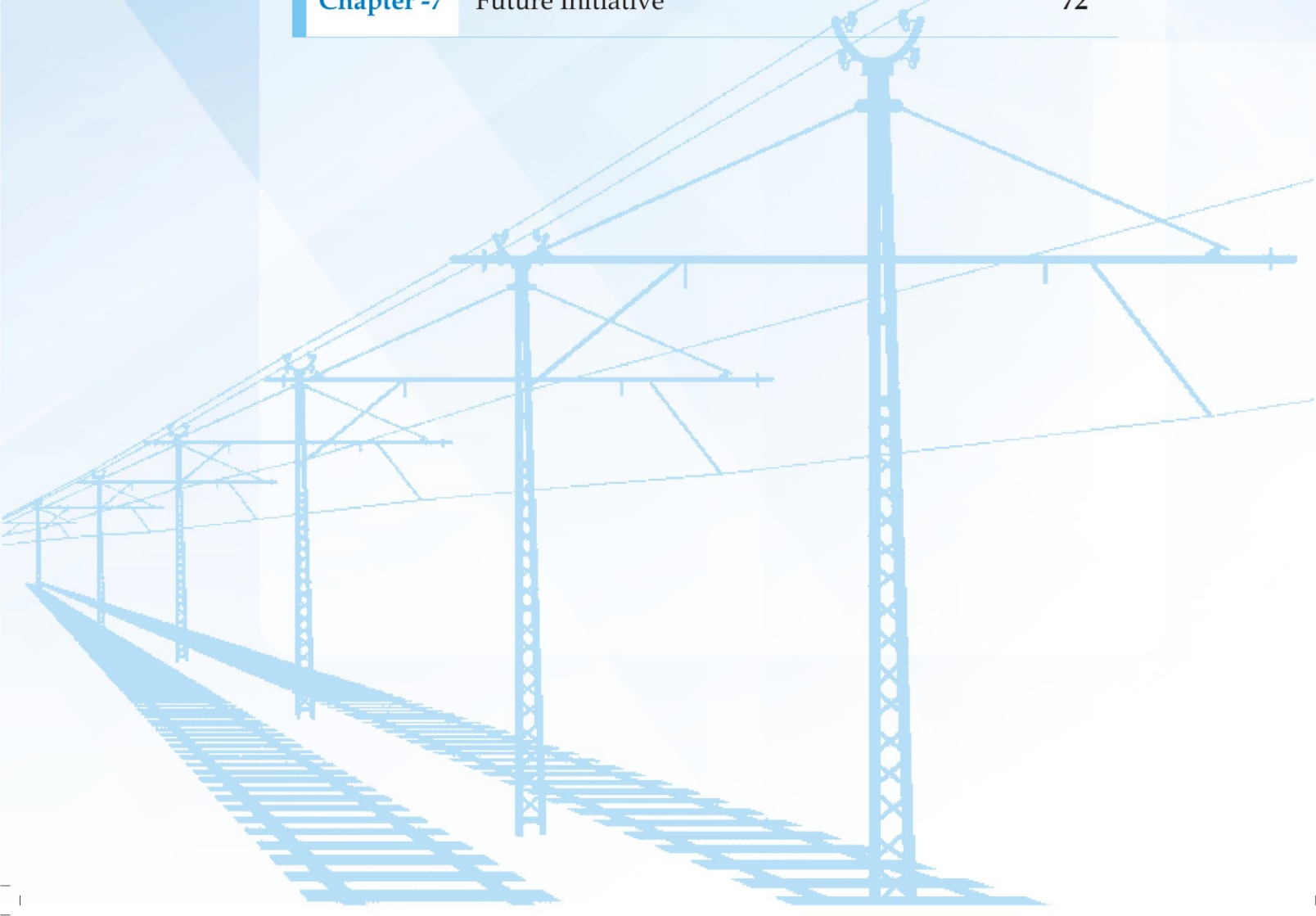



Rail History

Indian Railways - Way of Life (Story of - Electrification / Modernization)



First Passenger Train

First railway service in India started on 16th Apr. 1853 when the first train was flagged off from **Bombay** (Mumbai) to **Thane**, to cover a distance of 34 kms with **14 coaches** and 400 passengers.



The First Steam Loco

India put first step towards new age when it took manufacturing of steam locomotives in India. The **first steam loco** No. F-734 was built in 1895 by the **Ajmer workshop** of the Rajputana Malwa Railway.



By 1880 the Indian Railway system had a route length of about 14400 kms.

Old Railway Board Building, Shimla

Looking at the growing need, **Railway Board** was formed in 1901.

Indian Railways in Independent India



Rail Bhawan



Kolkata Metro

Kolkata became the first Indian city to get a **metro rail system** in **1984**, followed by the **Delhi Metro** in **2002**.

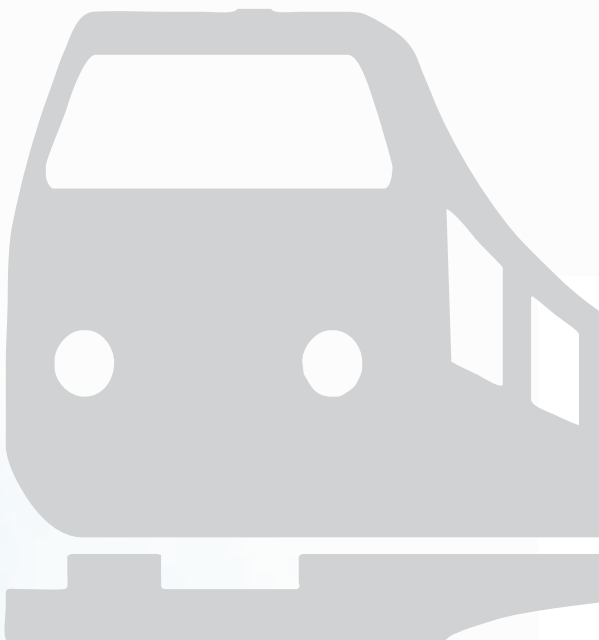

India inherited rail network after independence which needed substantial improvement. In order to connect important cities many lines were re-routed and new line were constructed. Indian Railways was formed by amalgamation of **42 railways** owned by the former Indian **princely states**. The network stood at **55,000 kms** after independence in 1947.

In 1952, the existing rail networks were divided into **six Zones** for administrative purpose. Further with prospering of the economy Indian Railway made all railway production indigenous. **1985** onwards **steam locomotives** were **phased out** and electric and diesel locomotives took their place.

2

Rail Electrification



2.1 Electrification Map

Railway
Electrification
Path Towards
Development



2.2 Brief History of Railway Electrification in Indian Railways



Inaugural Train at Victoria Terminus, Bombay



First Train on electric traction started on **1500 V DC System** from **Bombay Victoria Terminus** to **Kurla Harbour** on **3rd Feb. 1925**. This was the turning point in development of Railways and growth of sub-urban transport system for Mumbai City as also for other metropolitan cities. **Madras** was second metro city to get electric traction in Southern Railway on **11th May 1931**. Upto Independence, India had only **388 rkm of electrified tracks**.

Post-independence electrification of the **Howrah-Burdwan** section was carried out at **3000 V DC**. **EMU services** were started in Howrah-Sheoraphuli section by Pandit Jawahar Lal Nehru on **14th Dec. 1957**.



Production of **Electric locomotives** was simultaneously taken up indigenously at Chittaranjan Loco-motive Works (**CLW**) in **1960** and first **1500 V DC** electric locomotive for Bombay Area **Lokmanya** was flagged off on **14th Oct. 1961** by Pt. Jawahar Lal Nehru, the first Prime Minister of India.



25000 V (25 kV AC) Alternating Current traction System: Keeping in line with international standards for electric traction **25 kV AC** system was adopted in IR in **1961**. French National Railways (SNCF) provided initial technical assistance and consultancy.



In wake of industrial development in Eastern region and growth in freight traffic which could not be managed by steam traction, **electrification** was introduced in early 1960s from **Raj Kharswan to Dongoaposi on South Eastern Railway**. With a view to provide continuity of traction system, **Howrah - Burdwan** section of Eastern Railway and **Madras Beach - Tambaram** section of Southern Railway were converted to **25 kV AC** system by **1968**.

On recommendation of **J. Raj Committee report in 1978**, a number of electrification works were taken up in IR. A dedicated and specialised organisation for execution of Railway Electrification projects was created. Thus, **Central Organisation for Railway Electrification (CORE)** came into being at Nagpur, which was later shifted to Allahabad. A regular General Manager was posted in **CORE** from **July 1987** onwards.



2.3 Policy Objectives

In order to control spiralling fuel bill, reduce dependence on imported fossil oil, increase energy security of nation, reduce pollution, improve operational efficiency and operating ratio of IR, it is imperative that electrification is accorded priority in Railways.

Benefits of Electrification:

- **Electrification of Indian Railways as a powerful measure to achieve cost effectiveness.**
- **Traction Economy-Reduction in Operating Cost**

In terms of Line Haul Cost (Summary of End Results 2015-'16), electric traction is **cheaper** by about **47% for freight traffic & 50% cheaper for coaching traffic**, as compared to diesel traction. This is evident from table given below:-

| Line Haul cost per thousand GTKM (in Rs.) (as per Summary of End Results 2014-'15) | | | |
|---|----------|----------|----------|
| Freight | | Coaching | |
| Diesel | Electric | Diesel | Electric |
| 265.09 | 139.65 | 373.51 | 186.08 |

- **64.8% of freight traffic and 51.3% of passenger traffic** is hauled on **42.4% of electrified network** presently. **Fuel expense** on electric traction is only **37.03% of total fuel bill** of IR.
- Electric traction is more economical and plays a vital role in improving Operating Ratio.

System Capacity Enhancement

- Electric traction **improves throughput** and section capacity by about 15%, as it enables haulage of heavier freight and longer passenger trains at higher speed.

Green & Clean Energy

- Electrical traction can use alternate and non-conventional sources of clean energy, such as solar and wind energy sources.
- Regenerative energy produced in Three-Phase Electrical rolling stock during braking of trains, results in saving in energy consumption by **about 30%**.
- Contribution of electric traction of currently electrified tracks towards reduction in green house gas (GHG) emission is **3.36 million tonne carbon equivalents** per year.
- Environmental cost of electric traction, based on cost of abatement of green house gas emissions, is 0.015 Re./ton-km for electric traction and 0.051 Re./ton-km for diesel traction.
- In a study conducted by TERI, electric traction is found to be about three times more energy efficient than diesel traction.

Railway Electrification at a Glance as on 31st Mar.'15

| | |
|---|---|
| Total Route kilometers (rkm) on Indian Railways | 65808 km |
| rkm electrified | 26269 km (39.92%) |
| Goods traffic hauled by electric traction | 65.40% |
| Coaching traffic hauled by electric traction | 51.20% |
| Total traction fuel bill (RE 2014-'15)(diesel + Electric) | ₹ 30195 crore |
| Fuel expenses on electric traction (RE 2014-'15) (goods + coaching) | ₹ 10968 crore (36.32% of total IR fuel bill) |

As on 1st Apr.'16, **27999 rkm** energised which is **42.40%** of total route kilometers over Indian Railway.

2.4 ACHIEVEMENT IN LAST ONE YEAR

INFRASTRUCTURE:

1. Record electrification in a year in Indian Railways:

During 2015-'16, all time record of electrification of **1730 rkm** has been achieved, against target of **1600 rkm** set for the year by Prime Minister's Office. This is 25.81% higher than

previous record electrification of 1375 rkm achieved during 2014-'15. A target for electrification of **2,000 rkm** has been set for achievement during 2016-'17.

| Actual Achievement (in RKM) | | | |
|-----------------------------|----------|----------|----------|
| 2012-'13 | 2013-'14 | 2014-'15 | 2015-'16 |
| 1317 | 1350 | 1375 | 1730 |

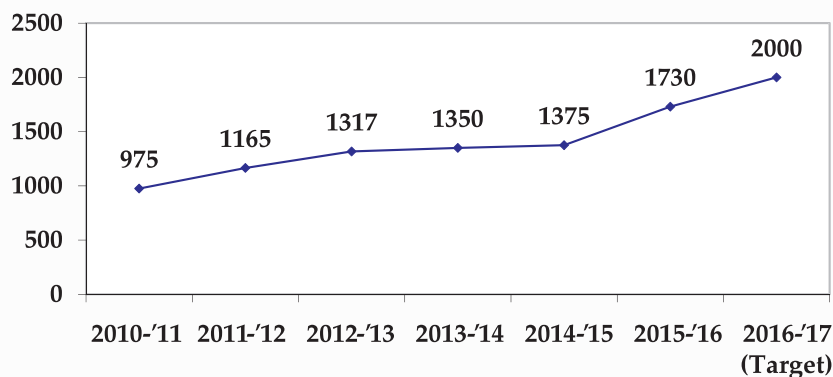

Figure: Railway Electrification Trends

2. Higher thrust on Railway Electrification:

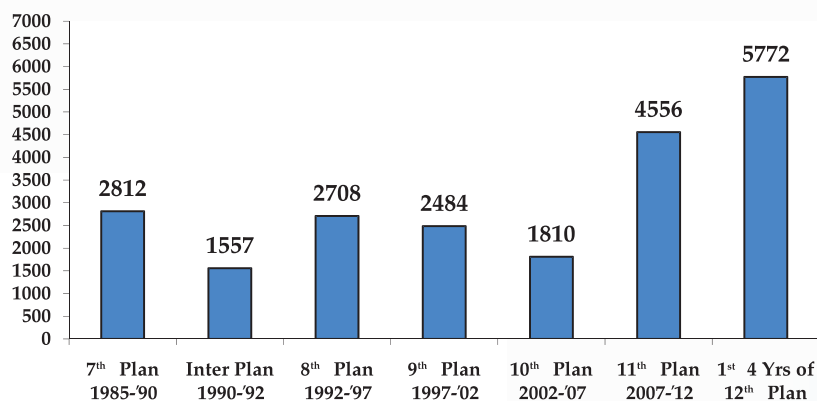

Figure: Plan wise Progress of Electrification

With a view to achieve cost economy in fuel economy and enhance transportation capacity, Ministry of Railways have decided to increase pace of electrification in the country. Accordingly, an **Action Plan for Electrification** has been approved by **Hon'ble MR**. To increase

pace of electrification; it is proposed to assign works to other Railway PSUs like **IRCON & RITES** including **PGCIL** (PSU of Ministry of Power). Electrification of balance BG tracks of **24,400 rkm** has to be executed as under:-

| AGENCY | | 2017-'18 | 2018-'19 | 2019-'20 | 2020-'21 |
|--------------------|-------------|-------------|-------------|-------------|-------------|
| CORE | 1500 | 2000 | 2000 | 2100 | 2100 |
| Rlys. PSUs | 500 | 1200 | 2000 | 2100 | 2100 |
| PGCIL (PSU of MOP) | - | 800 | 2000 | 2000 | 2000 |
| Total | 2000 | 4000 | 6000 | 6200 | 6200 |

- **28 new electrification projects** consisting of **6608 rkm** at estimated cost of **Rs. 6746 crore** was included in Railway Budget 2015-'16.
- **18 new electrification projects** consisting of **2569 rkm** at estimated cost of **Rs. 2741 crore** was included in Railway Budget 2016-'17.

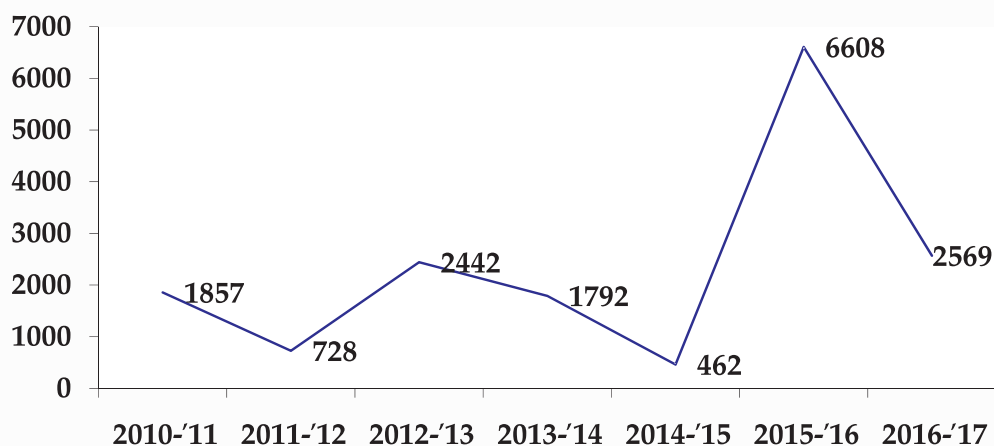
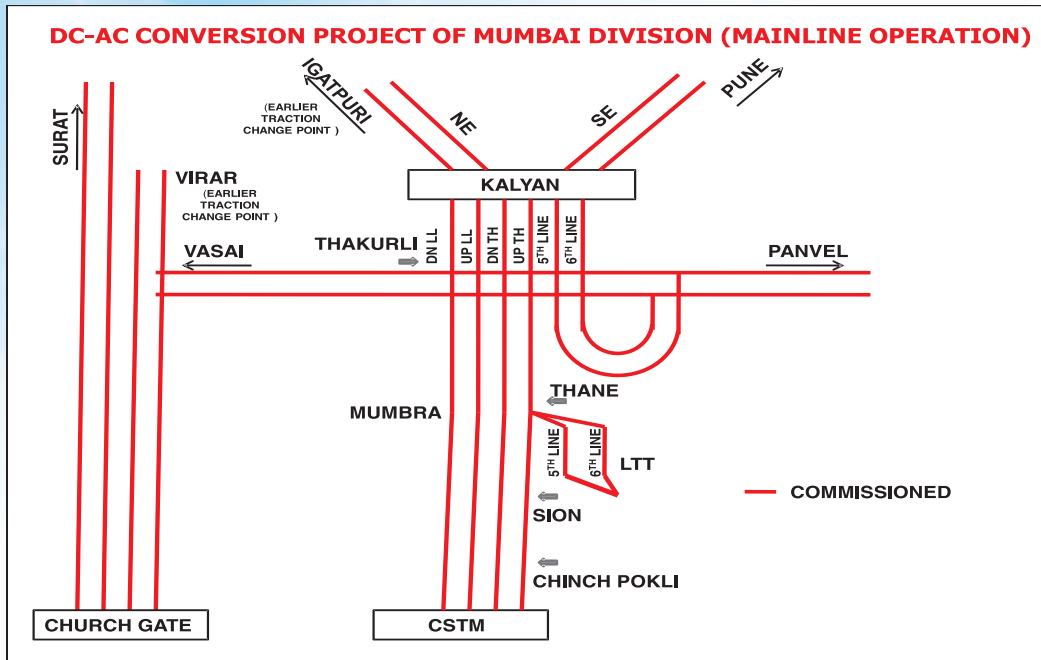

Figure : Railway Electrification Projects sanction Trends

3. DC to AC conversion in Central Railway:

One of most challenging railway projects for conversion of **1500 V DC to 25000 V AC** traction systems has been successfully completed over **entire Mumbai division** of Central Railway. This work of very complex nature has been carried out on busiest network of Indian Railways without any disruption to

sensitive commuter traffic. This will substantially improve traffic throughput and result in a cumulative **saving of Rs. 100-120 crore per annum**, apart from introducing State-of-Art train services for Mumbai suburban passengers with better passenger amenities, reduction in journey time and operating cost of Railways.



4. Development of High Rise Overhead Equipment:

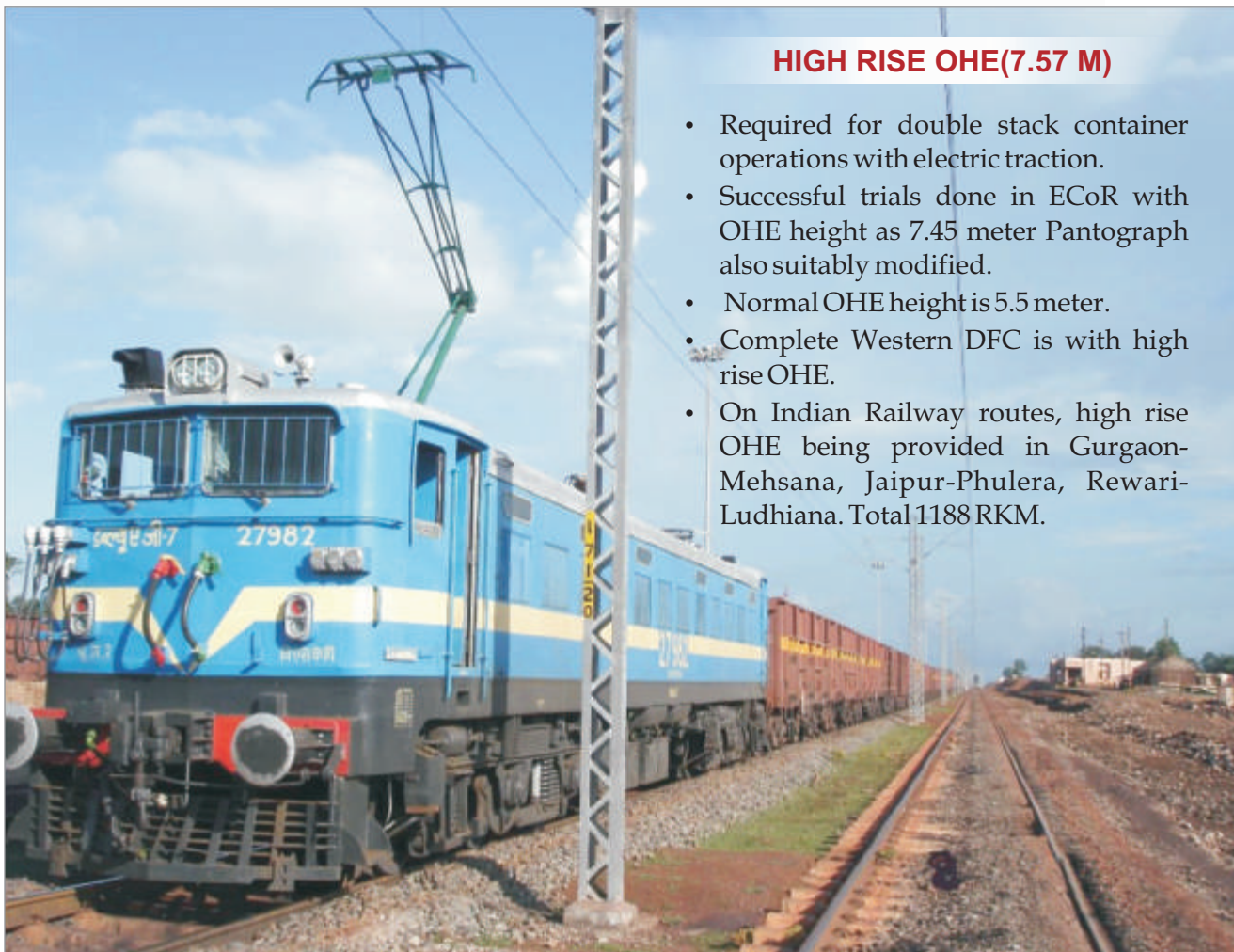

Photograph of actual trial in Jakhapura-Daitari section of ECoR

For operation of **Double Stack Container (DSC) Trains**, a major part of **Delhi-Ahmedabad route** including port connectivity routes in Gujarat will be constructed with **High Rise OHE**. This is first occasion when high rise OHE will be introduced in Indian Railways for operation of **7.1 metre high Double Stack Container trains**. Contact Wire height of High Rise OHE will be **7.57 metre against 5.55 metre** for normal OHE, which is a completely new design concept.

TOWARDS BETTER EFFICIENCY:

1. EPC Mode of Contract for RE Projects:

Engineering Procurement and Construction (EPC) mode of contract execution has been introduced in Railway Electrification for first time. It has been decided to award maximum number of future tenders on EPC mode.

2. Delegation of power to Zonal Railways:

Ministry of Railways has delegated power of acceptance of tenders and award of contracts, for all values, to Zonal Railways, except Railway Board purchase items. Further, full power has been delegated to General Managers for sanction of Estimates,

including variations and material modifications to certain percentage values over original cost. Further, power has been delegated to Chief Electrical Engineer, CORE for acceptance of tender value upto 300 crore. This will facilitate faster delivery of projects.

3. Re-designation of field officers of CORE:

In order to give more importance to field officers of CORE, designation of CEE (Chief Electrical Engineer) has been re-designated as **CAO, RE** (Chief Administration Officer) & **CPM** (Chief Project Manager) as **CPD** (Chief Project Director)

MORDERNISATION:

1. Mechanisation of execution:

For faster execution of Railway Electrification projects, emphasis has been put on mechanized execution of OHE construction works. It has been planned to introduce **Self Propelled type Wiring Trains** for faster and efficient wiring of both catenary and contact wires, within a much shorter block period, for which Technical Specification has been finalized and tender for pilot project has been opened and is under finalization.

For simultaneous stringing of catenary & contact wire. Will increase the pace of electrification



Self-Propelled Wiring Train

On similar lines, **Self Propelled type Multi Utility-cum Mast Erection Vehicles (MUMVs)** have been developed for faster mechanized mast erection within shorter block periods, and tenders have been invited for their procurement.



Self Propelled Mast Erection Vehicle

2. Directed preventive maintenance:

For measurement and recording of vital OHE parameters like contact wire height, stagger, implantation, gradient etc.

Likely failure locations identified and timely corrective action taken.



Tower Car with Measuring & Recording Instrumentation
(for predictive maintenance)

Measuring and recording Instruments, with IT based Analytical Tools will be fitted in 8-Wheeler Tower Cars, so as to enable more effective preventive maintenance of OHE with lesser amount of power and traffic block. Technical Specification for this purpose has been finalised and tender for procurement of **30 numbers of 8-Wheeler Tower Wagons with Measuring and Recording Instruments** has been invited.

3. Introduction of 8-wheeler DETC tower wagon:

Indian Railway for first time finalized purchase order for 8-wheeler Diesel Electric

Tower Car. In this regard, PO has been **issued** for **45 nos.** of 8-wheeler DETC tower wagon to **M/s Phooltas & M/s BEML**. Another tender for **53 nos** 8-wheeler DETC tower wagon has been opened and is under finalization.

4. New Technological Developments in Electric Traction

2x25 kV OHE system against 25 kV OHE on Eastern and Western DFC to reduce number of TSS and increase number of trains in section.

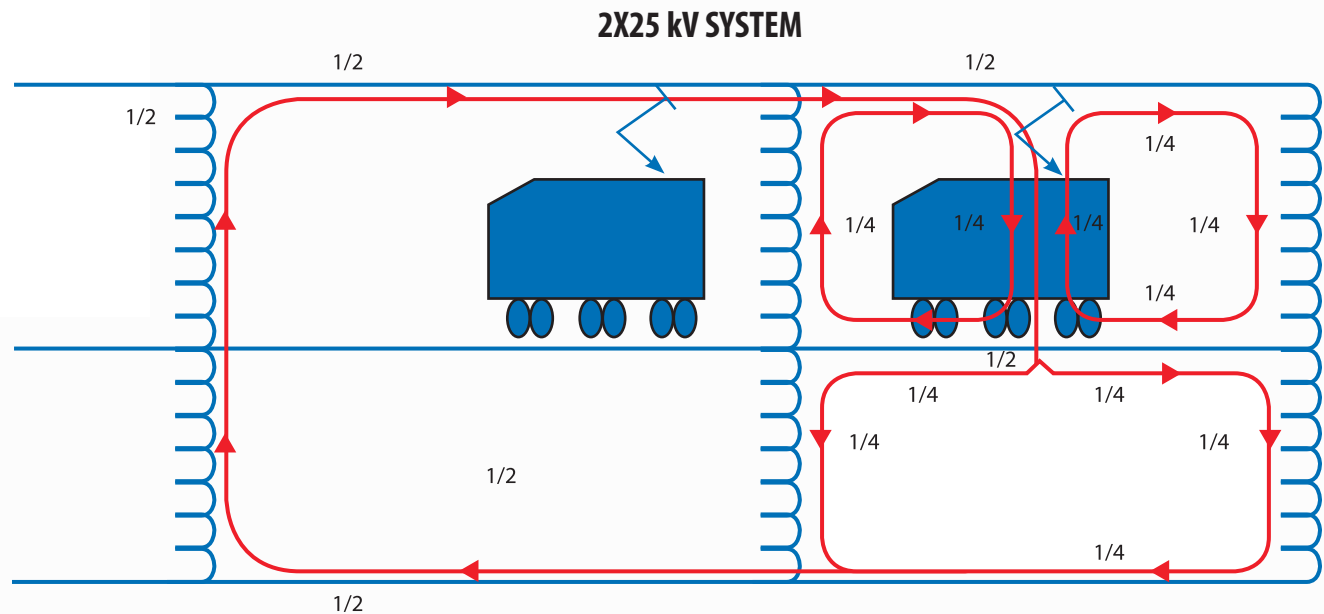

MAJOR OPERATIONAL ADVANTAGES OF 2x25kV SYSTEM

- Higher hauling capacity
- Increased Traction Substation spacing at 60-80 km apart against existing spacing of 40 km.
- Higher OHE current carrying capacity due to doubling of voltage (50 kV).
- Improved voltage regulation and reduced transmission line losses
- Seamless running of locomotives from 1x25 kV to 2x25 kV system

OPENING OF MAJOR ROUTES ON ELECTRIC TRACTION

1. With introduction of electric traction on **Ghaziabad-Meerut-Saharanpur** section in **2015-'16**, trains will run seamlessly from Delhi to Amritsar, Katra and Haridwar.
2. With introduction of electric traction on **Yelahanka-Dharmavaram** section in **Jul.'16**, route from Bangalore to Gooty was opened on electric traction and passenger and goods trains will run seamlessly from Bangalore to Gooty.
3. With introduction of electric traction on **Gonda-Domingarh** (Gorakhpur) section, Lucknow to Barauni is now opened on electric traction and passenger and goods trains will run seamlessly from Delhi, Katra & Mumbai to Gorakhpur.
4. With introduction of electric traction upto **Katra** in **Aug.'16**, IR has successfully introduced seamless end-to-end operation of electric trains from Katra to Kanniyakumari, integrating India as one nation.
5. Introduction of electric traction on **Varanasi - Phaphamau - Unchahar** including Phaphamu-Prayag-Allahabad is an important milestone in electric traction history of the country in connecting Varanasi and Allahabad seamlessly on electric traction.
6. With introduction of electric traction on **Pune-Daund** section in **Sep.'16**, route from Pune to Howrah & Pune to Katra will open on electric traction passenger and goods trains will run seamlessly.

3 Locomotives & EMUs



ELECTRIC LOCOMOTIVES

Story of Locomotives and EMUs on IR

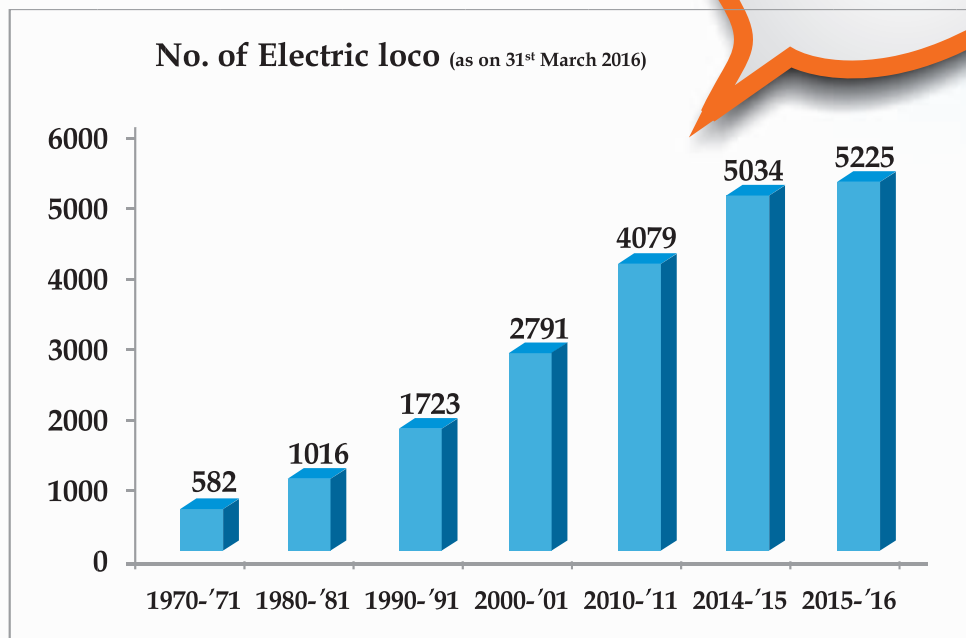

- As of 31st Mar.'16 there are 5225 electric locomotive. As part of modernization plan, Indian Railways imported thirty three **6,000 horsepower GTO** locomotives with 3-Phase drive technology based on GTO propulsion, along with transfer of technology. Over the years improvements in 3-Phase loco technology were made in terms of adoption of IGBT propulsion & other upgraded equipment designs to enhance reliability and operational performance. Three variants of 3-Phase locomotives namely **WAP₅**, **WAP₇**, and **WAG_{9H}** are now produced at Chittaranjan Locomotive Works (CLW) with **IGBT** traction propulsion.
- With continuous effort towards indigenization, **import content** of three phase Electric locomotives, which was initially 100% at time of its import from ABB Transportation (Switzerland) under ToT contract, has been reduced to only **2.47%**.
- Reliability of Electric locos has been improved consistently and percentage share of trains **lost punctuality** on account of Electric locomotives & Electric loco running staff is generally **1.2-1.4%** in total trains lost punctuality over Indian Railways.



After reaching a power level of 5000 hp, there was no further scope for up-gradation in the dc drive locomotives, as the capacity of equipment in the traction chain was fully utilised. During late 80's, development took place towards three

phase induction motor based drives for traction. There is 15-18% reduction in the energy consumption on account of regenerative braking.

Three Phase Technology



WAP₅ MU with Power through HV Cable

On 23rd July 1993 Indian Railways signed a contract with **ABB Transportation** (Switzerland) for importing freight and passenger class of locomotives together with transfer of technology agreement for indigenous manufacture.



Both WAP₅ and WAG₉ class have GTO based traction converters and microprocessor based control. This was the first time that CLW handled such high technology locomotives, and it needed a paradigm shift in the management of this technology.

WAP₅ loco has been **tested** successfully up to **180 kmph** and cleared for working up to **160 kmph** speed on Indian track conditions.



Six freight locomotives of WAG₉ class received in 1996 in fully assembled and tested condition. This had a rating of **6000 hp** with maximum

service speed of 100 kmph, capable of delivering **460 kN** starting tractive effort.



During the year 2000, after mastering vehicle application software by CLW engineers, a new variant WAP₇ was built by adapting the original WAG₉ design. WAP₇ is intended for passenger operation for service speeds up to

140 kmph, which is the maximum speed of Rajdhani and Shatabdi trains today. WAP₇ addresses the high-speed segment very well now.



A variant WAG_{9H} with an adhesive weight of **132 tonnes** was also developed capable of delivering nearly **52 tonnes** starting tractive

effort for operation (under good adhesion conditions) targeting 1 in 150 graded sections.

Advantages of three phase locos:

- Better reliability and availability of three phase locos
- It regenerates energy about 15-18%, a moving power house.
- Maintenance cost of a 3-phase locomotive is less due to absence of brush-gear/commutator in the traction motors and switchgears in the power circuit.
- 3-phase locomotive operates at near unity power factor throughout the speed range.

IGBT based propulsion technology

Insulated Gate Bipolar Transistors (**IGBTs**) are today's state-of-the-art power electronics for the traction system of electric locomotives. They replace the previous generation of GTO (gate turn-off thyristors). In contrast to conventional transistors, IGBTs operate at very high currents (> 1000 A) which were not as efficient. The principle benefit of IGBTs over GTOs is a much (3 to 4 times) higher switching frequency. This reduces the current required and therefore the heat generated, giving smaller and lighter units. The high switching frequencies also smoothens

the acceleration process and reduce the traction noise. The IGBT itself is integrated in a complex power module which includes besides the transistor the circuits and the cooling etc. These "peripherals" offer even more potential for future optimisation than the IGBT itself.

Benefits

- Reduced switching losses (compared to GTO)
- Less cooling required (no organic coolants required)

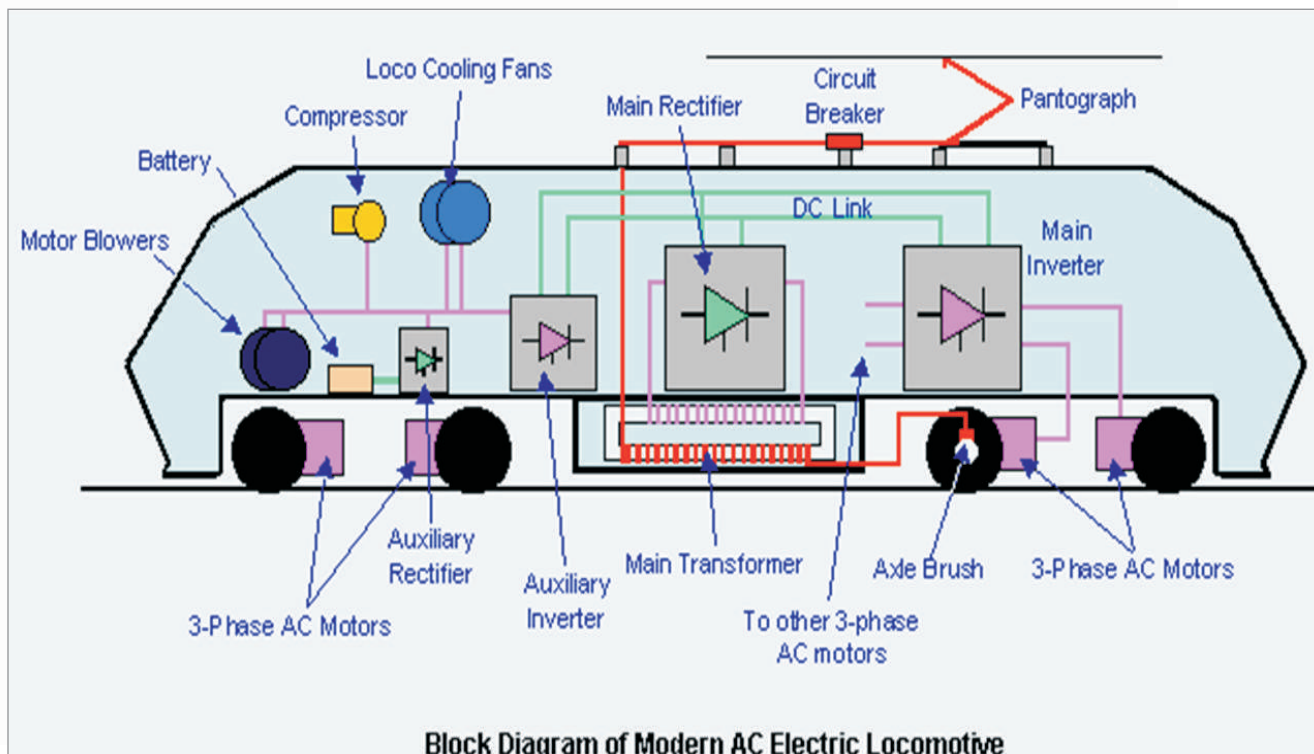

Types of Locos on IR

| SNo | Class of Loco | Year of Manufacturing | Horse Power | Technology |
|-----------------------|-------------------|-----------------------|----------------------|---------------------|
| DC Locomotives | | | | |
| 1 | WCM ₁ | 1954 | 3170 | English Electric |
| 2 | WCM ₂ | 1956 | 2810 | English Electric |
| 3 | WCM ₃ | 1957 | 2460 | English Electric |
| 4 | WCM ₄ | 1960 | 3290 | Hitachi |
| 5 | WCM ₅ | 1961 | 3700 | CLW |
| 6 | WCM ₆ | 1996 | 5000 | CLW |
| 7 | WCG ₁ | 1925 | 2400 | Swiss Loco works |
| 8 | WCG ₂ | 1970 | 1640 | CLW |
| AC/DC Locos | | | | |
| 9 | WCAM ₁ | 1975 | 3640(AC) 2930(DC) | CLW |
| 10 | WCAM ₂ | 1995 | 4720(AC) 3780(DC) | BHEL |
| 11 | WCAM ₃ | 1997 | 5000(AC) 4600(DC) | BHEL |
| AC Locos | | | | |
| 12 | WAM ₁ | 1959 | 2870 | KM-KRUPP-SFAC |
| 13 | WAM ₂ | 1960 | 2790 | Mitsubishi |
| 14 | WAM ₃ | 1964 | 2790 | Mitsubishi |
| 15 | WAM ₄ | 1970 | 3640 | Mitsubishi |
| 16 | WAP ₁ | 1980 | 3760 | CLW |
| 17 | WAP ₃ | 1987 | 3760 | CLW |
| 18 | WAP ₄ | 1994 | 5000 | CLW |
| 19 | WAP ₅ | 1993 | 6000 | ABB |
| 20 | WAP ₆ | 1998 | 5000 | CLW |
| 21 | WAP ₇ | 2000 | 6350 | CLW |
| 22 | WAG ₁ | 1963 | 2900 | SNCF |
| 23 | WAG ₂ | 1964 | 3180 | Hitachi/ Mitsubishi |
| 24 | WAG ₃ | 1965 | 3150 | Europe |
| 25 | WAG ₄ | 1966 | 3150 | CLW |
| 26 | WAG ₅ | 1984 | 3900 | CLW/BHEL |
| 27 | WAG ₆ | 1987 | 6000 | ASEA |
| 28 | WAG ₇ | 1992 | 5000 | CLW/BHEL |
| 29 | WAG ₉ | 1996 | 6000 | ABB/CLW |

Electric loco holding (As on 1st Apr. '16)

| Loco Type | 2016 | 2015 | 2014 | 2013 | 2012 | 2011 | 2010 | 2009 | 2008 | 2007 | 2006 | 2005 | 2004 | 2003 | 2002 | 2001 |
|-------------------|-------------|-------------|-------------|-------------|-------------|-------------|-------------|-------------|-------------|-------------|-------------|-------------|-------------|-------------|-------------|-------------|
| WAG4 | - | - | - | - | - | - | - | - | - | - | - | - | - | - | 7 | 79 |
| WAM ₄ | 149 | 208 | 239 | 281 | 311 | 349 | 375 | 399 | 402 | 453 | 471 | 470 | 471 | 471 | 472 | 473 |
| WAP ₁ | 64 | 64 | 64 | 64 | 64 | 64 | 64 | 64 | 64 | 64 | 64 | 64 | 64 | 65 | 65 | 67 |
| WAP ₄ | 774 | 735 | 705 | 678 | 642 | 593 | 557 | 514 | 471 | 412 | 372 | 328 | 297 | 266 | 246 | 195 |
| WAP ₅ | 90 | 81 | 75 | 58 | 50 | 35 | 25 | 20 | 18 | 17 | 16 | 14 | 14 | 13 | 12 | 10 |
| WAP ₆ | - | - | - | - | - | - | - | - | - | 4 | 12 | 13 | 14 | 15 | 15 | 15 |
| WAP ₇ | 253 | 212 | 176 | 144 | 109 | 90 | 70 | 47 | 33 | 33 | 32 | 22 | 12 | 8 | 4 | - |
| WAG _{5A} | 622 | 684 | 642 | 650 | 637 | 678 | 635 | 635 | 636 | 647 | 653 | 640 | 640 | 644 | 646 | 646 |
| WAG _{5H} | 532 | 473 | 517 | 509 | 524 | 484 | 528 | 528 | 531 | 521 | 515 | 532 | 537 | 528 | 528 | 529 |
| WAG ₆ | 11 | 11 | 15 | 15 | 15 | 15 | 15 | 16 | 16 | 18 | 18 | 18 | 18 | 18 | 18 | 18 |
| WAG ₇ | 1959 | 1919 | 1839 | 1691 | 1518 | 1333 | 1179 | 1056 | 954 | 849 | 777 | 712 | 676 | 648 | 624 | 578 |
| WAG ₉ | 684 | 557 | 468 | 385 | 332 | 287 | 237 | 204 | 158 | 119 | 86 | 71 | 61 | 53 | 46 | 34 |
| WCAM ₁ | - | 3 | 14 | 35 | 58 | 46 | 47 | 47 | 47 | 47 | 47 | 47 | 52 | 52 | 52 | 52 |
| WCAM ₂ | 20 | 20 | 20 | 20 | 20 | 20 | 20 | 20 | 20 | 20 | 20 | 20 | 20 | 20 | 20 | 20 |
| WCAM ₃ | 53 | 53 | 53 | 53 | 53 | 53 | 53 | 53 | 53 | 53 | 53 | 53 | 53 | 53 | 53 | 53 |
| WCAG ₁ | 12 | 12 | 12 | 12 | 12 | 12 | 12 | 12 | 12 | 12 | 12 | 12 | 12 | 12 | 12 | 12 |
| WCG ₂ | - | - | - | - | 8 | 18 | 30 | 42 | 44 | 51 | 57 | 57 | 57 | 57 | 57 | 57 |
| WCM ₆ | 2 | 2 | 2 | 2 | 2 | 2 | 2 | 2 | 2 | 2 | 2 | 2 | 2 | 2 | 2 | 2 |
| YAM ₁ | - | - | - | - | - | - | - | - | - | - | - | 18 | 18 | 18 | 19 | 20 |
| TOTAL | 5225 | 5034 | 4841 | 4597 | 4355 | 4079 | 3849 | 3659 | 3461 | 3322 | 3207 | 3093 | 3018 | 2943 | 2898 | 2860 |

Front Runners



WCM₁ (DC) - Manufactured by English Electric/Vulcan Foundry. First electric loco of 3700 hp with speed potential of 105-110 kmph used in India.



WCAM₁ (AC/DC) - Introduced in 1975 having hp of 2930 DC/3640 AC & max. speed 110 kmph. This class of loco was generally found only in Bombay Central - Ahmedabad section.



WCAM₂₃ (AC/DC) - From BHEL, including passenger - specific WCAM_{2p}, is rated 2900 hp in DC mode and 4700 hp in AC mode (max. speed 120 kmph). These are used by WR for fast trains, running at up to 120kmph on Virar-Godhra AC section.



WAM₄ - First indigenously designed and built electric loco (first units delivered by CLW in 1970-'71). They were produced until 1997. With 3640 hp & max. speed 105/110 kmph, these locos were backbone of passenger services IR in past.



WAG₅ - A very successful class introduced in 1984 primarily meant for freight traffic with 3850 hp & max speed up to 105 kmph, fulfilled ever growing coaching demands too. Last loco delivered by CLW in 1998.



WAP₄ - Indigenously designed, higher power (5000 hp) passenger loco able to run at 140 kmph. A 24-coach (1430 t) passenger rake can be accelerated to 110 kmph in 338 seconds (over 6.9 km) by a WAP₄; to 120kmph in 455 sec. (10.5 km); and to 130 kmph in 741 sec. (20.5 km).



WAG₇ - Built by CLW, these represent next indigenous design step up from WAG₅ locos. Used primarily for goods haulage, these locos have a high-adhesion bogies and Hitachi motors providing 5000 hp with maximum speed of 100 kmph.



WAP₅ - Imported from ABB/AdTranz in 1995 along with ToT, these are equipped with state-of-art GTO converters and 3-Ph motors including regenerative braking. With max. speed of 160 kmph, these locos are being deployed to haul prestigious Rajdhani/Shatabdi trains. CLW is producing these locos since 2000.



WAG₉ - First few locomotives were imported from ABB. Since Nov'98, CLW started producing these high horse power (6000 hp) locomotives with indigenous components. They have also GTO converters and 3-Phase propulsion initially and later upgraded in-house with IGBT technology.



WAP₇ - Identical to WAG₉ with modified gear ratio (72:20) and application software. 140 kmph top speed. 6125 hp max. power; 6000 hp continuous at wheel rim. Intended to haul heavier, 26-coach passenger trains.

Major Technical Initiatives



To cater to proposed semi high speed train up to **200 kmph**, **up gradation** in **driving gear system** of one WAP₅ locomotive has been done in CLW.



To run **24 coach trains up to 160 kmph**, WAP₅ locos have been fitted with High Voltage MU couplers to work in **Multi formation** with single pantograph.



To run heavier and longer train with amalgamation of two or more trains, **Distributed Power Wireless Control** systems are provided on Electric freight locomotives so that two or more locos can be provided anywhere in the train formation and can be controlled from leading loco. In future once technology is stabilized, crew can also be saved with this system.

Achievement in last one year

Electrical (Traction Rolling Stock) Directorate is mainly responsible for providing electric locomotives and crew to support train operation.

- As on 1st Nov.'16, electric locomotive fleet consists of 5327 locomotives as per details given below:

| Three-phase | | Conventional | | | Total |
|-------------|---------|--------------|---------|--------------|-------|
| Passenger | Freight | Passenger | Freight | Mixed (WCAM) | |
| 392 | 775 | 951 | 3134 | 75 | 5327 |

2. Production Units:

Chittaranjan Locomotive Works:

- Chittaranjan Locomotive Works located in West Bengal was set up in **1950** and turned out **first steam locomotive** in **Nov. 1950**. CLW now produces electric locomotives and is one of largest Electric Locomotive manufacturers in world.

- CLW started manufacturing **electric locomotives** in **1961-'62** by producing **five WCM**, electric locomotives. CLW has manufactured 5833 electric locomotives so far. During **2015-'16**, CLW achieved highest ever out turn of **280** locomotives.
- CLW has completely switched over to production of IGBT based High Horse Power three-phase locomotives from 2016-'17.
- CLW has produced 148 three-phase electric locomotives upto 31st Oct.'16 against target of **298** locos for **2016-'17**.
- Electric Loco Assembly and Ancillary unit (ELAAU) of CLW has been set up at Dankuni to assemble electric locos and augment CLW's capacity to manufacture electric locos. **ELAAU/Dankuni** has been given target of assembling 24 three-phase freight electric locomotives during 2017-'18 which will increase progressively.

- Production targets for CLW for 2017-'18 have been revised to produce **300** three-phase electric locomotives with **115** coaching and **185** freight locomotives.
- CLW is producing **WAP₅** locos which is suitable to run trains at **160 kmph** and is being used to haul **Gatiman Express** between New Delhi and Agra which is the fastest train in India.

3. Workshops :

- Six workshops located at Bhusawal/CR, Kharagpur/SER, Perambur/SR, Dahod/WR, Charbagh/NR and Kancharapara/ER

undertake unscheduled repair works and periodic maintenance of electric locomotives. These workshops undertake maintenance of more than **400** electric locomotives annually.

- Traction Motor Workshop at Nasik Road/CR and Kanpur/NCR undertake rewinding, reshafting and unscheduled repairs of traction motors.

4. Crew Position (Electric traction) on IR as on 1st Apr.'16:

Crew management and training is vital for safety and train operation. Vacancy position of crew as on 1st Apr.'16 is given below:

| | LP(M) | LP(P) | Motormen | LP(G) | LP (Shunting) | ALP | Total | % Vac. |
|--------------|--------------|--------------|--------------|--------------|---------------|--------------|--------------|--------|
| SS | 3701 | 4597 | 1066 | 20159 | 4343 | 25831 | 59697 | 21.51 |
| OR | 2852 | 3765 | 855 | 14472 | 3153 | 21760 | 46857 | |
| Vac. | 849 | 832 | 211 | 5687 | 1190 | 4071 | 12840 | |
| Vac.% | 22.94 | 18.10 | 19.79 | 28.21 | 27.40 | 15.76 | 21.51 | |

5. Electric Loco Sheds :

Electric locomotives are being maintained in **30** electric loco sheds located on Indian Railways network. 5327 electric locos are being maintained in these 30 loco sheds against sanctioned capacity of 4065 locos. Out of 30 Electric Loco Sheds, **16 sheds** are homing **more than 200 locos** and except six smaller sheds at SRC, RPM, BKSC, HWH, ASN and a new shed under commissioning at KJGY, others are homing nearly 200 locos.

In most of Railways, there is acute shortage of maintenance staff in Electric Loco Sheds as creation of posts for new sheds and for new locos being inducted is not being done.

6. Development Initiatives :

- CLW has been advised to provide **Water Closets** in five WAP₅/WAP₇ locos during current financial year.

- All locos to be turned out from CLW shall be fitted with **cab air conditioners**. CLW has placed order for supply of 798 AC units for fitment on electric locos. 24 units (12 locos) have been fitted on electric locomotives. Regular fitment of **cab ACs** will be done by CLW w.e.f. Nov.'16.

- So far, CLW has manufactured **33 WAP₇** locomotives fitted with **Hotel Load Converters (HOG)**. All WAP₇ locos to be turned out by CLW should be fitted with Hotel Load Converters. HOG power supply will do away with requirement of diesel power car for feeding electric supply to coaches for train lighting and air conditioning, thereby carrying extra passenger coach. We save around **3000 litres of diesel in one round trip** between NDLS-Mumbai by Rajdhani Express with HOG and reduce noise pollution.

- The **Mission Raftar** envisages doubling of average speed of freight trains from **25 kmph** to **50 kmph** over next **five** years by providing **right powering** (close to **two hp per tonne** of trailing load) of locomotives which can haul freight trains at higher speed. In order to achieve this, initiatives have been taken for **right powering** of locomotives by replacing single WAG₇ locomotives with **multi WAG₇** locomotives. Three groups have been identified comprising of ECoR, SER, SECR; SCR, CR and ER, ECR, NCR. This requires an addition of 640 locos. This will substantially increase speed of freight trains.
- Trials for Distributed Power Wireless Control System (**DPWCS**) are going on in SCR (six), SER (three), ECoR (three) and SECR (one), total 13 pairs of WAG₇ (11) and WAG₉ (two). Plans have been drawn to provide the same on all WAG₉ locos manufactured by CLW. This year, 75 sets are planned to be provided by CLW.
- Progressive electrification of Railways will also bring down **Line Haul Cost**. For electric coaching line haul cost is ₹ 123.5/1000 GTKM and for diesel coaching it is ₹ 213/ 1000 GTKM, making electric traction cheaper by ₹ 89.5/ 1000 GTKM.
- Electrification works are in full swing on Northern, North Eastern and Northeast Frontier Railways. Electrification of Gonda - Basti - Gorakhpur route of NER has already been completed. With above electrification, trains from NDLS to BJU via Gonda - Basti - Gorakhpur have been taken over on Electric traction. On completion of RE works in various sections, around **130 trains** have been taken on electric traction **over last 4/6 weeks** resulting in an annual saving of diesel fuel of ₹ 280 Crore.
- It is planned to upgrade existing **6000 hp WAG₉** locos to **9000 hp** to improve hauling speeds of freight trains.
- It is also planned to acquire passenger coaches capable of hauling at 200 kmph on routes identified for semi high speed operation (160-200 kmph).

HOG System over Indian Railways



Head On Generation (**HOG**) technology, transfers electric power from loco's pantograph to coaches instead of 'End on Generation' in which Power Cars equipped with diesel generator are provided at both end of trains.

Commercial service of HOG scheme involving one 3 phase electric, loco and 12 passenger coaches and two power cars have been started in India from 21st Feb.'11 between New Delhi-Kalka and back in train No.12005/06 New Delhi-Kalka Shatabdi Express.

Advantages:

- Pollution free and cheaper power from OHE as compared to EOG system and SG system
- Highest reliability as compared to SG and EOG system due to reduced number of generating equipments
- No additional irritating noise or smoke if power is taken from Electric/Diesel locomotive
- Low maintenance requirement
- Reduced dead weight as compared to SG & EOG system

Presently **eight trains are working on HOG system** providing saving 8926075 litres of diesel cost about **Rs. 50 crores** per annum.

Future plan: Work in progress for three rakes of SDAH Rajdhani (12313/14), two rakes of Patna Rajdhani (12309/10), two rakes of Ranchi Rajdhani (12453/54), one rake of 12243/44 (CBE-MAS) STB and three rakes of train (12269/70, 12007/08, 22625/26).

Electrical Multiple Units (EMUs)

Brief History of EMUs in Indian Railways

Electric Traction on the G.I.P. Railway, India



His Excellency The Governor of Bombay Speaking



Inaugural Train at Victoria Terminus, Bombay

IR has electric multiple units in operation in several suburban sections (Mumbai, Chennai, Kolkata, Bandel-Katwa, Hyderabad, Bangalore, Delhi -NCR etc.).

First electrified suburban train ran between Victoria Terminus-Kurla on 3rd Feb.1925 providing 150 services in **four car rakes** formation. Electrical equipments were supplied by M/s English Electric Company (E.E.Co.) and

Mechanical equipments by M/s Metropolitan Vickers England. These were 10 feet wide cars with cement flooring and teak wood panelling. It was 1500V DC stock with resistance control and vacuum brake system.



In 1951 for the first time **12 feet** wide EMU stock with **electro-pneumatic** brake system was introduced in Mumbai area. This stock was imported from M/s E.E. Co., England. Afterwards on **14th Dec. 1957** **3000V DC** EMU introduced on Howrah Division of Eastern Railway between Howrah-Seoaphuli. These were imported from M/s S.I.G., Switzerland, (Electrics were supplied by M/s B.B.C., Baden & M/s Secheron) and M/s Jessops, England (Electrics were supplied by M/s A.E.I., England).

In **1958**, 12 feet wide **1500V DC** EMU stock of same design as E.E.Co., was imported from Japan (N.S.S.K./Toshiba/Hitachi).

In **1963-'64**, **BG 25kV AC** EMUs introduced for the first time in Sealdah Division in Calcutta area. Electrics were imported from M/s Hitachi, Japan and M/s AEI, England whereas coaches were manufactured by ICF, Madras (25 kV, DC Motors, Tap changer control).



In 1965-'66, ICF manufactured M.G. AC EMUs. Electrics were imported from M/s Nichimen, Japan thereafter from 1968-'69 ICF Madras and M/s Jessops Co., Calcutta started manufacturing EMU coaches with M/s HEIL Traction equipments (Both 1500V DC and 25 kV AC).

In 1989-'90 ICF manufactured Thyristor control 25 kV MG EMUs for Chennai area. Electrics were supplied by M/s GEC, England and in 1993 introduced Chopper Control on 20 Nos. BG DC EMU motor coaches in Association with BARC.

In a major technological leap Indian Railway adopted 3 phase Traction Drives Equipments suitable for dual voltage 1500V DC/25 kV AC system with regenerative braking features for use in Mumbai area.

In 1981-'82 ICF, Chennai manufactured Metro coaches with M/s BHEL & M/s NGEF traction equipments (750 V DC with 3rd Rail - Resistance control)

In 2012-'13 ICF, Chennai manufactured 13 Air conditioned rakes with M/s BHEL traction equipments for Kolkata Metro.



Railway has taken decision to introduce energy efficient state of the art rakes with 3 phase propulsion system with regenerative braking in Kolkata Metro. In this regard, an order for procurement of 14 fully furnished rakes for Kolkata Metro with IGBT based propulsion system and regenerative braking system has been placed on M/s Dalian, China.

Further two rakes with indigenous development of 3 phase propulsion system with regenerative braking are under manufacturing at ICF.





116 energy efficient AC/DC rakes with 3 Phase IGBT propulsion systems have already been introduced in Mumbai Suburban area with regenerative braking features since 2007. In Western Railway the total energy regeneration of 64 EMU rakes with regenerative braking is 82.6 million kWh per Annum and the total saving is approx. ₹ 65.39 crore per Annum. In Central Railway the total energy regeneration of 52 EMU rakes with regenerative braking is 66.7 million kWh per Annum and the total saving is approx. ₹ 53.35 crore per Annum.

72 energy efficient AC rakes are under manufacturing at ICF with 3 phase Insulated Gate Bipolar Transistor (IGBT) based propulsion system and regenerative braking system. Out of which 58 rakes have been commissioned in Mumbai area since Jan.'15. These rakes will first replace energy inefficient over-aged DC EMU rakes and will be used later for augmentation/additional services.



BEML, Bangalore had manufactured and supplied Stainless Steel EMU rakes with DC propulsion system against the order placed on them. All the six rakes have already been inducted in passenger services in Southern Railway, Eastern Railway and South Eastern Railway.



2 Rakes manufactured with indigenous Insulated Gate Bipolar Transistor (IGBT) based 3 Phase propulsion system by ICF for Mumbai.



Air Conditioned EMU rake for Mumbai Suburban area with BHEL Electrics has been manufactured and delivered to Mumbai which is under testing.

The Main-line EMU (MEMU) have a width of 10'8" to allows operations in main line. Earlier versions of MEMUs had a top speed of 60kmph. RDSO improved on these by increasing the horsepower of the traction motors and providing a weak-field arrangement in them for higher speeds.

All new MEMUs have toilet facility. Railways have also planned to manufacture MEMUs with Insulated Gate Bipolar Transistor (IGBT) based 3 Phase propulsion system having speed potential of 110 kmph.



GPS based Passenger Announcement System in EMU rakes in Mumbai Suburban area, also planned for other than Mumbai area.



Train Lighting/Air Conditioning (TL/AC)

Lighting in passenger coaches was introduced starting around 1897. **Jodhpur Railway** was first to make electric lighting standard on all its coaches, in **1902**. A long time ago, steam locos used to have 24V turbine generators to provide power for lighting and other appliances in coaches. In general, only 'first' and 'second' class coaches had lights and fans for every compartment, 'inter' class had only lights, and third class coaches had just two lights, one at each end near door. Provision of lights and fans as standard equipment in all compartments was legislated in 1952.

Individual coaches are powered by axle-driven generators which charge storage batteries that power lights, fans and other electrical fittings. Older coaches have 24V (less often 48V) circuitry and have dynamos connected to axles by belts. Newer coaches have 110 V circuitry and use belt-driven 4.5 kW, 110 V alternators. Both systems use banks of 24V batteries (mostly lead-acid batteries of an 800 Ah capacity) for back-up power. LHB stock uses 4.5 kW alternators (6 kW for air-conditioned stock). In 1990s, there was a big push to convert all old stock with 24V systems to 110 V system.

In older stock, for powering air-conditioning equipment, an inverter was used to convert DC output of a set of batteries to 415 V AC. For some time now, however, groups of 110V alternators delivering 18-22 kW each have been used to power air-conditioning equipment (voltage is stepped up to 415 V). Most recently, RDSO has developed a newer 25 kW 110 V alternator with better power circuitry.

Many air-conditioned coaches are not self-contained with regard to power supply. For such coaches, a 'mid-on generator' (MOG) is used; this is a 415 V 3-phase alternator (either in one of coaches or in a separate 'power-car'),

output from which is used both for air-conditioning, and (stepped down to 110 V) for lights & fans. Some 'end-on generators' (EOG) also generate 415 V 3-phase AC.

Prior to 1930's, various arrangements for cooling interiors of passenger coaches existed, mostly for first-class coaches. North-Western Railway introduced air-conditioned stock in late 1930's (earliest was probably Frontier Mail in 1936 or 1937). BCCI Railways also experimented with air-conditioning at about same time. By early 1950's, air-conditioning was available on several long-distance trains. For example, in 1952-'53 there were air-conditioned services between Bombay and Howrah, Delhi and Madras (Grand Trunk Exp.), Bombay and Delhi, Bombay-Amritsar (Frontier Mail), Bombay-Virangam (Saurashtra Mail), and Bombay-Ahmedabad (Gujarat Mail). These all used AC units that were mounted beneath coach body (under-slung), interconnected by pipes. Self-contained roof-mounted units appeared in year 1980.

First **fully air-conditioned** train was introduced in **1956** between **Howrah** and **Delhi**. Popularly known as **AC Express**, it ran on Grand Chord; later there were two, one running on Grand Chord and other on Main Line. Another train popularly known as AC Express was Dakshin Exp. between Madras and New Delhi in 1960s.

AC Chair Car stock was introduced around **1955**. Until about 1979, air-conditioning was available only in AC Chair Car and in AC First Class. Around **1979 two-tier AC** coaches were introduced. **3-tier AC** coaches were introduced in **1993** (RCF) and used on **Howrah Rajdhani** via Patna. (first such coach was ER 2301 A, later changed to ER 94101 A.) First 60 three-tier AC coaches had 67 berths each, while all later ones have 64 berths.

NEW DEVELOPMENTS

- **Provision of Thermal sensation index controller in LHB AC coaches.**

Temperature inside air condition coaches should be maintained in such a manner that there should not be any need of blanket, only woollen lohi should be sufficient.

A thermal sensation index based controller was developed by IIT Delhi. This controller would save energy and also improve passenger comfort. NR has provided this controller in two coaches 04066/WGACCW & 15636/WACCN on 25th Dec.'14 & 11th Jan.'15 respectively. On satisfactory performance and good passenger feedback NR & WR were advised to provide same in 25 coaches each for extended trial.

- **Provision of solar panels in coaches.**

Hon'ble MR has announced for green energy during 2011-'12, in response to that

NR has provided Solar lighting based train lighting system in four narrow gauge coaches plying on Pathankot-Jogindernagar Route in Kangra Valley section and fourteen narrow gauge coach plying on Kalka-Shimla section on trial basis since 2011. N.Rly. has also provided one BG GS coach no. 20022 GS NR with Solar PV units for technology demonstration in Dec'14. This coach is running in DLI- Rewari train no. 54085/86. WCR has also provided solar panel on roof of BG coach no. 94408 GS on dated 18th May'15 for charging batteries & for electrical load on trial basis running in intercity Exp (Rewa-JBP). Further, as a part of green initiative on Rail coaches and to have extended trials for one year in all weather conditions and understand all practical issues. It has been decided that one number of day running intercity express train each in NR and SR may be provided with solar panel modules on roof top of alternate coaches for one year trial in



all weather condition as per scheme and fifty percent of narrow gauge coach holding of PTK-JDNX section & KLK-SHM section

should be provided with solar panels for extended trial.



Provision of capacitor bank for power factor improvement in LHB EOG coaches

Hon'ble MR has pronounced during budget speech 2015-'16 "More berths will be made available through increase in number of coaches to meet growing demand for confirmed seats on trains". It is also desired by CRB that running of 24 LHB coaches in Rajdhani/Shatabdi trains with End on generation (EOG) System & Head On generation (HOG) system should be expedited.

There is continuous demand for augmenting Rajdhani/Duronto LHB EOG rakes to run with 20 to 24 coaches. To overcome the problem of voltage drop & limitation in current carrying capacity, electrical capacitors are being provided in each coach of LHB rakes.

Zonal Railways have been advised to provide capacitors in existing EOG coaches. So far, Zonal Railways have provided capacitor bank in 2075 EOG coaches out of 3501 EOG coaches. (59.3%).

Achievement in last one year

1. Toilet onboard 4500 HP WDG_{4D} Diesel Electric Locomotive

Hon'ble MR inaugurated First WDG_{4D} 4500 HHP locomotive no. WDG_{4D} 70486 fitted with **vacuum based toilet and biodigester system** on 6th May'16. Indian Railways has designed

and manufactured a HHP Diesel Electric Freight Locomotive at DLW fitted with Vacuum type toilet having microprocessor based controls and inbuilt safety interlocks on board. It is equipped with environment friendly and self sustaining bio-digester technology for onboard sewage treatment.



WDG_{4D}-70486 homed at TKD Diesel Loco Shed

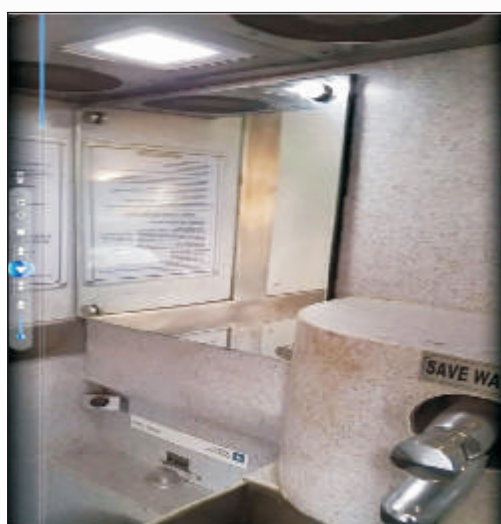

2. **First Air Conditioned (AC) DEMU** manufactured by Integrated Coach Factory, Chennai



3. **Bio diesel:** 5% Blending of Bio Diesel started from 5th Jun.'15 (i.e. World Environment Day) on Indian Railways.



Brief:

Mechanical Engineering (Traction) dte. is mainly responsible for providing diesel locomotive and crew to support train operation.

1. **Diesel Locomotive Fleet** as on 1st Oct.'16 is as under:

| BG | MG | NG | Total |
|--|-----|-----|-------------|
| 5704 (5343 Mainline + 361 Shunting) | 258 | 149 | 6111 |

2. **Diesel Loco Sheds:** Diesel Locomotives are maintained at 44 BG, 8 MG and 12 NG Sheds located on IR network.

3. **Production Units** - Production Units engaged in production of Diesel Locomotives and parts are as under:

a) **Diesel Locomotive Works (DLW):** manufactures diesel-electric locomotives and its spare parts. DLW locomotives have power outputs ranging from 2,600 hp (1,900 kW) to 5,500 hp (4,100 kW). Currently DLW is producing EMD GT46MAC and EMD GT46PAC locomotives under license from Electro-Motive Diesels (formerly GM-EMD) for Indian Railways. Some of its EMD locomotive products are WDP_{4r}, WDP_{4Dr}, WDG_{4Dr}, WDG₅ and others.

b) **Diesel Loco Modernization Works (DMW):** DMW manufactures various diesel components/sub-assemblies along with manufacturing/rebuilding of diesel electric locomotives and power packs.

- Manufacture and supply of high quality components and sub-assemblies as spares.
- Manufacture of Components hitherto imported achieving import substitution and timely availability
- Remanufacture of critical assemblies for unit exchange system of Diesel Locomotives maintenance system of Railways.
- Rebuilding Locomotives and power packs and turning them out in state-of-art condition. Retrofitting the locomotives with systems incorporating latest technological development in this process.

4. **Workshops** - Workshops set up for diesel locomotives for repair, maintenance and manufacturing of rolling stock and related components, which are located at 06 places on IR. (Parel/CR, Jamalpur/ER, Charbagh/NR, Ajmer/NWR, Goldenrock/ SR, Kharagpur/SER).

5. **Diesel Electric Multiple Units (DEMUs)** :- holding of DEMUs as on 31st Mar.'16 is as under:

| Type | DPC | DTC | TC | Total |
|--------------|------------|-----------|-------------|-------------|
| 700 HP | 78 | 65 | 131 | 274 |
| 1400 HP | 347 | 9 | 1038 | 1394 |
| 1600 HP | 10 | 0 | 40 | 50 |
| Total | 435 | 74 | 1209 | 1718 |

6. **HSD Fuel:** -There are 259 Railway Consumer Depot /Railway Diesel Installation on Indian Railways for supply of High Speed Diesel Fuel for Diesel Locomotives.

7. **Crew Position (Diesel Traction) on IR:-** Crew management and training is vital for Safety and train operation. Vacancy position of crew is as under:

| DSL Running Staff Position on IR as on 01.04.2016 | | | | | | | | |
|--|--------------|--------------|-----------------|--------------|--------------|--------------|--------------|---------------|
| | LP(M) | LP(P) | Motorman | LP(G) | LPS | ALP | Total | % Vac. |
| SS | 3623 | 4582 | 37 | 14359 | 4366 | 21777 | 48744 | -24.9 |
| OR | 2857 | 3184 | 30 | 11006 | 2514 | 17040 | 36631 | |
| Vac. | -766 | -1398 | -7 | -3353 | -1852 | -4737 | -12113 | |
| % Vac. | -21.1 | -30.5 | -18.9 | -23.4 | -42.4 | -21.8 | -24.9 | |



Efficient use of Energy in Indian Railways and its Energy Conservation Initiatives



*"Yesterday I was clever so I wanted to change the world.
Today I am wise, so I am changing myself"*

---Rumi

Energy Scenario

Indian Railways (IR) has one of world's largest railway network spread over 117,000 track kilometers (66,030 route km) connecting 8,073 stations and serving people of this glorious nation since 1853. In 2014-'15, Indian Railways transported 8.39 billion passengers to their destinations, i.e. more than 23 million passengers a day. In addition, it transported around one billion tons of freight across length and breadth of country. IR acts as a vehicle of inclusive growth connecting regions, communities, ports; and centers of industry, commerce, tourism and pilgrimage across country.

Indian Railways, along with national highways and ports, is backbone of India's transport infrastructure. Currently, more than 33% of total freight traffic (in terms of ton-kilometers) of country moves on rail. Further, share of Railways in certain core infrastructure sectors such as coal, power, steel, cement and in other critical sectors like fertilizer is as high as 70%. The reach and access of its services are continuously expanding with continuous improvement in its services through its dedicated team of 1.32 million and by use of cutting-edge technologies.

Efficient utilization of energy

Indian Railways have been very conscious about saving energy by its efficient use. It is said that "energy saved is energy generated". From efficient energy utilization perspective Electric traction offers a unique feature of 'regenerative braking', where kinetic energy of train is re-converted into electrical energy and is fed back to the electric grid. This feature is successfully incorporated in **WAG₉** and **WAP₅** class of locomotives capable of saving upto **20%** and on all new electrical multiple units (EMU) having potential of saving **30%**. While this feature saves energy it also increases life of wheels and improves availability of locomotive for running trains and thereby makes electric traction more economical.

Over last five years Railways have been able to improve upon Specific Energy Consumption (SEC) by about **18.9%** through various energy conservation initiatives. This in effect means a saving of about **₹ 2,656 crores**. As per BEE assessment for 2014-'15, **an improvement of 3.3%** was achieved over previous year in use of energy in traction application. Indian Railways has also bagged **87** energy conservation awards in last few years. Some of major initiatives on traction side are:

Electric Locomotives

- All new Locomotives will be produced with three phase IGBT technology having regeneration capability
- High efficiency IGBT based **12000 hp** new generation Locomotives will be produced
- Regular counselling of Loco Pilots for resorting to **maximum coasting** and use of **regenerative braking**.
- Electric loco idling in sheds and yards are kept to minimum
- Regular counselling of Loco Pilots for switching 'OFF' blower in case yard detention is more than 15 minute.
- Switching 'OFF' trailing loco in case of multi units (MU) carrying light load.
- Benchmarking of energy consumption through use of Microprocessor based Energy Meters provided in all-Electric Locomotives

EMU and AC coaches

- All new EMUs will be produced with three phase technology having regeneration capability
- Provision of coasting boards and power boards on routes.
- **About 175** energy efficient rakes with 3 Phase IGBT propulsion system have

already been introduced in Mumbai Suburban area with regenerative braking feature since 2008.

- These rakes have saved about **230 million units** of energy per annum giving a saving of about ₹ **175 crore** per annum over Central & Western Railways.
- Capacitor banks have been provided for improvement of power factor and to reduce feeder current in LHB EOG AC coaches and Power cars.
- Energy efficient LED lights are being provided in all Railway coaches/EMU.



EMU fitted with LED lighting

Traction Sub-stations

- Over **0.95 Power Factor** is to be maintained in traction sub-stations.
- Switching off of standby transformer which saves **about 0.3-0.5%** of total annual traction energy consumption.
- Regular energy audit of traction sub-station and its implementation.

Head on Generation (HOG)

Railways have planned to introduce energy efficient **Head on Generation (HOG) scheme**.

In this scheme, complete electric power for Air-Conditioning, Lighting etc of Rail coaches is received from the Locomotive. This will replace power from diesel generator.

Vision for Non-Traction Energy

Indian Railways consume around 2.5 Billion Units of electricity for non-traction usage, spending about ₹ 1,700 cr. per annum. Consumption of non-traction energy has largely been static especially from 2008 onwards, which is an indication of efficacy of energy conservation efforts of Indian Railway.

Consumption of non-traction electrical energy and bill paid

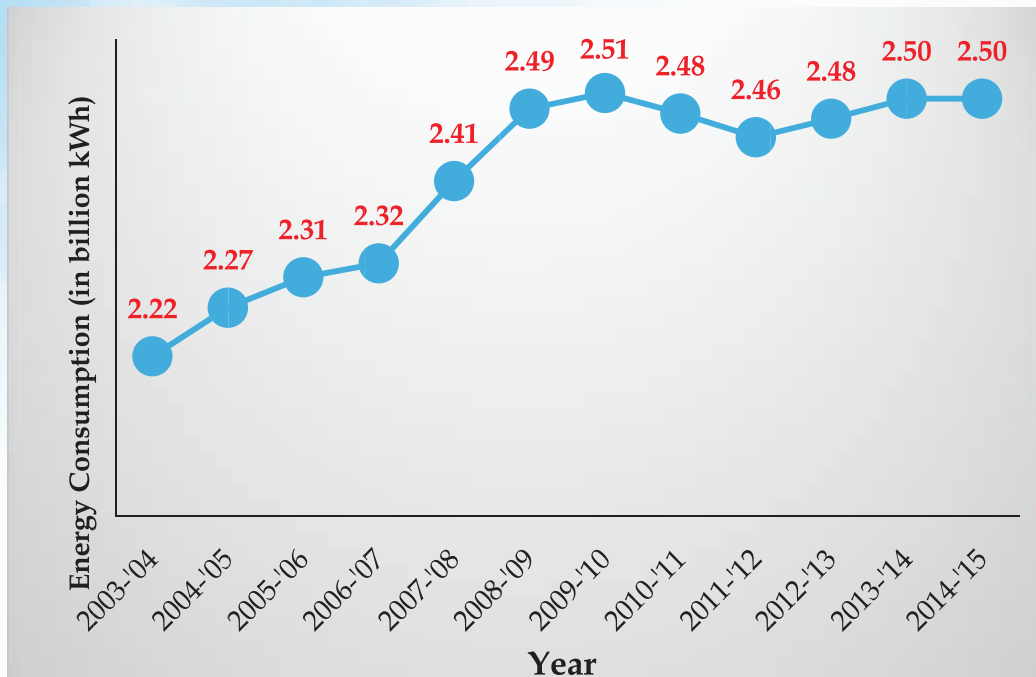

This energy feeds the manufacturing workshops, maintenance depots, Colonies, Station area, Platforms. As can be seen from above figure, demand is largely static over last 10 years, reflecting impact of energy efficiency measures.

Economy in end use has a key focus point with progressive deployment of LED based lighting and energy efficient machines.

A SCADA system will add to savings by optimal utilization of man & electric power. To further improve upon energy efficiency in non-traction field following are been taken up:

- Energy audits of large load centres, to assess demand profile and actual end use to map energy consumption pattern,
- cost efficient energy sourcing strategies, to reduce cost of procurement of electricity,
- implementation of utility SCADA, for better supervision and control of utility grid,

- Creation of a viable funding model whereby improvements are cost neutral to IR.
- Introduction of Smart grid technologies
- Building Automation and Control System
- Introduction of Smart Metering for accountal

However, considering energy efficiency opportunities available and upcoming expansion, it is felt that there is immense scope to further improve upon this by adopting and use of innovative energy efficiency technologies, solutions and best international practices.

Energy Conservation Initiatives in IR

Indian Railways started energy conservation journey much earlier and at every stage took benefit of best available technology, whether it was **replacement of T-8 FTL by energy efficient T-5 & CFL fittings**, provision of LED lights, energy efficient ceiling fans, occupancy sensors, use of star rated equipments etc. These

are resulting into a saving of about average 3% of electricity as per assessment made by Bureau of Energy Efficiency for non-traction application during last three years despite about 5% increase in connected load. These efforts have been regularly recognized at national level and several prestigious awards were given to IR.

As a part of energy conservation drive, Indian railways has carried out energy audit of 448 facilities till Mar.'15 and additionally, energy



Signing Ceremony of MoU between Ministry of Railways, Ministry of Power & Ministries of Renewable Energy for co-operation in Power for Railways & harnessing of Renewable Energy on 12th Aug.'15.

Signing ceremony of MoU

audits of 195 facilities has been carried out during 2015-'16. For moving ahead on energy conservation, IR has signed Memorandum of Understanding (MoU) with Ministry of Power and BEE for co-operation to improve Energy Conservation in IR in presence of **Sh. Suresh Prabhakar Prabhu, Minister of Railways and Sh. Piyush Goyal, Minister of State Independent Charge for Power, Coal and New & Renewable Energy**. Additionally, an MOU between Railway Energy Management Company Limited and Energy Efficiency Services Limited for implementation of Energy Conservation projects over Railways was also signed with an aim to provide a frame work for promoting future solutions and facilitate Railways to bring a change in its energy mix.



Inauguration of International Summit

As part of capacity building of railways staff on energy efficiency, "International Summit on Energy Efficient Technologies in Railways" was held on 6th Nov.'15 at Taj Palace, New Delhi to share several energy efficient technologies adopted by railways across other countries and also to emphasize on energy management system in zonal railways and IGREENRI portal has been developed by Centre for Railway Information Systems (CRIS) to disseminate green initiatives adopted across Railways.



Railway Board has issued directives to Zonal Railways to utilize LED tube light fittings and under Domestic Efficient Lighting Programme (DELP) Scheme, more than **10 lakh LED bulbs**

have been distributed to railway staff till Sept.'16. In addition, **1.68 lakh LED bulbs** were installed by Zonal Railways in railway stations and service buildings till now.



Facade LED lighting at Mumbai CST station



LED lights installed at Railway stations

Some other measures implemented on non-traction side for energy conservation are:

- 1) Replacement of tube lights with LED tube lights.
- 2) Replacement of 90 W ceiling fans with 60 W ceiling fans.
- 3) Automation of Pumps with GSM based techniques.
- 4) Use of energy efficient pumps
- 5) Micro-controller based Automatic Platform
- 6) Lighting Management System with segregation of 70% / 30% circuits
- 7) Use of 3 stars and above labelled electrical products and equipment
- 8) Solar based LED lighting system for level crossing gates
- 9) Use of solar water heater in place of electric geyser
- 10) Provide occupancy sensors in offices.

- 10) To takeup this goal of energy efficiency, IR have become a part of PAT scheme of BEE. Under this 22 Designated Consumers has been declared (16 Zonal Railways and six production units).
- 11) Policy issued for use of LED lighting for all Railway applications.

Energy consumption in Traction & Non-traction

Improvement of **specific energy consumption in traction segment in last six years** of Indian Railways and energy consumption in **non-traction in last five years** is given below.

SEC (in kWh/ 000 GTKMs) in last six years

| S.No. | Year | Specific Energy Consumption (in kWh/ 000 GTKMs) | | | |
|--------------------------------------|----------|---|-------------|-------|--------------|
| | | Passenger | % Reduction | Goods | % Reduction |
| 1 | 2009-'10 | 19.6 | | 7.29 | |
| 2 | 2010-'11 | 19.4 | 1.02 | 6.79 | 6.85 |
| 3 | 2011-'12 | 19.0 | 2.06 | 6.43 | 5.30 |
| 4 | 2012-'13 | 18.9 | 0.52 | 6.13 | 4.66 |
| 5 | 2013-'14 | 18.8 | 0.53 | 6.08 | 2.12 |
| 6 | 2014-'15 | 18.9 | 0 | 6.86 | 0 |
| Improvement in last six years | | | 3.6% | | 18.9% |

Energy consumption of Non-traction in last five years

| Year | Energy consumed in million kWh |
|----------|--------------------------------|
| 2010-'11 | 2483 |
| 2011-'12 | 2458 |
| 2012-'13 | 2478 |
| 2013-'14 | 2492 |
| 2014-'15 | 2503 |

Energy consumption of Non-traction in last five years

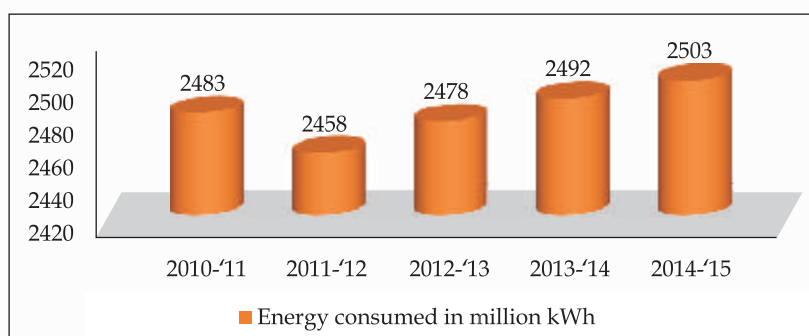

IR-UNDP-GEF Project

This UNDP supported GEF financed project aims to-

- Develop a long-term energy efficiency and conservation programme to reduce energy consumption and emission of greenhouse gases in Indian Railways
- Develop institutional capacities and support technical training to enable adoption of energy-efficient technologies
- Implement proven energy-efficient technologies and measures
- Pilot demonstration of energy-efficient technologies and measures to build capacity and confidence on energy efficiency

- Enable greater knowledge sharing and learning on cost-effective technologies that can reduce GHG emissions

Developments so far

- Strengthened the institutional capacity of Indian Railways by creating a **Centre of Excellence (COE) on energy efficiency technologies** and solutions at Indian Railway Institute of Electrical Engineering (IREEN), Nasik, Maharashtra. Under this project, IRIEEN has set up training & testing

facilities of pump, motor, Solar cum wind hybrid system, HVAC performance, Compressor systems & Energy Auditing instruments lab and also developed Computer Based Training (CBT) module on improving energy efficiency of electrical appliances/equipments. The testing facilities will be used for energy efficiency courses of one week duration for practical energy performance training and CBT module is used for providing one week training on improving energy efficiency of appliances.

Motor & Pump training facility at IRIEEN, Nasik



- Under the institutional capacities and technical training component, 791 Railway officers/supervisors were provided training on Computer Based Training (CBT) module and practical training on improving energy efficiency of electrical appliances/equipments at Indian Railway Institute of Electrical Engineering (IREEN), Nasik, Maharashtra and at National Academy of Indian Railways (NAIR), Vadodara, Gujarat.
- Developed energy audit guidelines, manuals, and procedures for most of railways energy intensive operations (e.g. production units, traction substations, workshops, production units, maintenance depots and buildings etc.).
- Conducted Energy auditing of 15 facilities which includes Railway stations, workshops, hospitals & building across Indian Railways systems to improve energy efficiency & for energy conservation.
- Gap analysis was carried out for Indian Railways for identifying opportunities for improving energy efficiency and also to define areas for implementation of energy efficient technologies and measures.
- Set up Technology Information Resource and Facilitation Desk (TIRFAD) at Research Design & Standards Organization (RDSO), Lucknow Uttar Pradesh.
- Across India, electrical lights in 150 compartments in passenger trains, have been

replaced with energy efficient LED lights. Maintenance costs have declined, lighting quality is much better and it's expected that this measure will save over 4 million kilowatt hours.

- As sun sets on Dadar railway station, located in India's financial hub of Mumbai, platform 5 is distinct. Entire platform is lit with LED lights. Platform and reservation bookings areas are visibly brighter. On average, an LED light provides 50,000 burning hours compared to 5,000-8,000 from conventional lighting systems.
- The demonstration at Dadar, which witnesses amongst highest passenger traffic in the state, is part of a new energy efficient, building management system implemented earlier this year. Intelligent building management system is a real-time, online monitoring tool that allows railway officials to know immediately when there is a problem in electrical power usage, monitoring consumption patterns, and allowing engineers to immediately take action.
- As railways embarks on ambitious growth plans, it's supported also by an online platform railsaver.gov.in developed by Centre for Railway Information Systems (CRIS) which provides updated energy data across 16 zones of Indian railways. Information and analysis gathered through this platform will inform Railways future strategies.
- CRIS has also designed & developed IRGREENERI website to disseminate information regarding green initiatives taken by Indian Railways which was launched by Minister of Railways. The website will act as a knowledge sharing platform on green initiatives and best practices.
- Till Aug.'16, 47 Railway officials have been visited U.K., Australia, Germany & Spain's "Centre of Excellence" for understanding latest technologies/measures adopted on energy efficiency so that this measures can be replicated for Indian Railways.
- For embarking effective usage of online platform i.e., railsaver.gov.in (portal), Centre for Railway Information Systems (CRIS) has developed "Railsaver Mobile App", which shall be used providing updated energy consumption data of 16 zones of Indian railways. This Railsaver mobile app were official inaugurated by Hon'ble Minister of Railways on International Conference of "Decarbonization of IR -Mission Electrification" on 3rd Nov.'16, in New Delhi.

Launch of Railsaver Mobile App at International Conference



- To increase confidence of Indian Railways staff in application of various energy efficient technologies and solutions, new technologies and measures are being demonstrated to prove their applicability in Indian environment.
- Details of various pilot projects have been adopted in Indian Railways are as follows:
 - i. Optimal light control system over Delhi division
 - ii. Smart sense & smart grid system at Baroda house, New Delhi
 - iii. Provision of automatic light & fan control for New Delhi Railway station
 - iv. Implementation of SCADA on New Delhi Railway station
 - v. Supply, fixing, testing & commissioning of retro-fitment of led lights in 150 non ac sleeper class coaches (GSCN) of TL depot in Delhi Division
 - vi. Provision of building management system for stations & Railway offices for implementing energy efficiency measures at Dadar station, Central railway
 - vii. Automation of pumping arrangement at Ghaziabad, Northern Railways
 - viii. Bay lighting in workshops & loco sheds in Northern Railways
 - ix. Provision of 200 super energy efficient fans in Delhi Division
 - x. Installation of VVVF (variable voltage variable frequency) drives for lifts
 - xi. Provision of solar pumps over Delhi Division
 - xii. Automation of pumping arrangement at Jaipur Division, Northern western Railways.
 - xiii. Demonstration of Energy Efficient Technology on IT platform through 500 AMR meters covering Delhi division, Northern Railway.

Measures to improve efficiency of Diesel Locomotives

(a) Operational improvements

Rationalization of Fuelling pattern: An analysis of Railway Consumer Depots (RCD) wise fuel price has been conducted and following points have been implemented to reduce fuel bill. Maximum fuelling from RCDs which are cheaper and lesser from RCDs which are costlier. Each Railway has made a set of 4-5 RCDs which are cheaper and maximum fuelling is being done from these RCDs. Analysis of RCDs at on freight circuits has been done and full tank fuelling is being done at RCDs having lowest price along the route of train.

Diesel Electric Multiple Unit: DEMU Diesel power cars (DPCs) have smaller engines in comparison to a Diesel Locomotive and consume less fuel. Replacing short distance Passenger trains (having 5-10 coaches) with DEMUs will give fuel saving of approximate 10%.

(b) Technological Improvements

Locomotives have been steadily upgraded with various fuel saving technologies like fuel efficient kit, Auxiliary Power Unit (APU), multi-grade engine oil, Low idle feature etc. This has resulted into steady improvement in specific fuel consumption. Various projects currently being undertaken for improving fuel efficiency are:

Multi-Genset Locomotive: It has been developed by RDSO and DMW in collaboration with NREC of USA. In a Multi-Genset locomotive, single large engine is replaced by three smaller engines. An on-board computer monitors power requirement and shuts down/starts engines as per load demands, which

makes it more fuel-efficient. Two such locomotives have been turned out by DMW/PTA. Trials have shown saving up to 17% fuel in passenger operations. Besides fuel saving, there is a reduction of 85%-90% in NOx and particulate emissions compared to uncontrolled locomotive emissions.

Auxiliary Power unit (APU): In order to save fuel during idling Indian Railways is providing a system called Auxiliary Power Unit (APU) in Diesel Locomotives. APU is a self-contained unit containing a small diesel engine coupled to a compressor and alternator for battery charging. It has its own set of controls, accessories and is integrated to existing microprocessor control system of locomotive. In APU System Main Engine shuts down and small 25 HP Engine starts, and charges batteries and air brakes pipes, when loco idles for more than 10 min. Diesel engine of APU consumes only three litres of diesel per hour in comparison to 25 litres by the main engine. Besides fuel saving, there would be a reduction in lubricating oil consumption and wear and tear of main engine. Use of APU also results in lower CO₂ emission and other pollutants like HC, NOx, CO etc. Expected savings per loco fitted with APU is Rs. Nine lakhs/year on account of saving in fuel oil alone. Its cost is about Rs. 10 lakhs on a new and 10-20 lakhs on existing locomotives depending on scope of modification required for fitment. Payback period is one-two years. Indian Railways plan to fit APU on 100% of new Locomotives.

Common Rail Electronic Direct Injection (CReDI): A first on large diesel engines, IR plans to introduce CReDI gradually on its fleet of locos. CReDI provides accurate metering of fuel, complete combustion, reduction in emission and optimizing power output while reducing fuel

consumption. Expected fuel saving 3-5%. This is being developed for diesel locos by RDSO.

Guidance for Optimised Loco Driving (GOLD): This is a GPS based driver guidance system, which assists loco pilot in optimizing fuel consumption with an eye on terrain ahead. It advises loco pilot to lower throttle if there is a down gradient ahead or to throttle up if there is a climb ahead. It also warns crew of signals, stations, and level crossing gates ahead. Successful trials have been conducted and this system will be proliferated on locomotives. Fuel saving to the tune of 12% has been realised.

Miller cycle turbocharger: Miller Cycle turbocharger increases power density of engine without exceeding thermal and mechanical limits. Miller Cycle turbocharger is designed to provide high boost pressure (> 3.5 bar) and is used with a modified cam shaft to suit Miller cycle timings. It gives a reduction in fuel consumption of around 2%, NOx emissions by around 20% and exhaust gas temperature up to 50°C.

(c) Alternate fuels

Bio-Diesel: Railway started 5% blending of Bio-diesel in High Speed Diesel (HSD) for traction purpose from 5th Jun.'15, the World Environment Day. Progressively orders are being placed and coverage of bio-diesel is being increased.

Indian Railways used 4986.8 kilolitres (KLs) of Bio-diesel during financial year 2015-'16. Second phase procurement of Bio-diesel has commenced. A total of 51 RCDs have been identified for implementation of 5% Bio-diesel during second phase. This will take total number of RCDs, using Bio-diesel to 87 during next six months.

Compressed Natural Gas: IR has already started running CNG based DEMUs on Northern Railway and have a plan to convert about 100 more DEMUs to run on dual fuel i.e. CNG and diesel.

Liquefied Natural Gas: IR is working to develop locomotives which can run on LNG.

Conclusion

To improve Indian Railways financial viability, reversing fuel bill trend was an important goal, as it constituted about 30% of ordinary working expenses. To take

forward the mission of efficient utilization of energy budget 2016-'17 had pronounced to cover all Railway Stations with LED luminaries in next two to three years and to obtain star rating for various Railway installations. As part of this about 251 Railway stations have already been provided with 100% LED lighting. Under this program 4000 more stations are planned to be taken up. To take ahead provision of LED lights at all stations, ESCO mode is being pursued. A Policy directive in this reference is being formulated and will be issued soon by Railway Board.



The New Paradigm of Electric Power Procurement

Reducing Cost of
Power Procurement
in IR



*"Everyone here has the sense that right now is one of those moments
when we are influencing the future"*

---Steve Jobs

Background

Although Indian Railway (IR) is a bulk consumer, it pays extremely high charges for traction power. Being a national resource and dominant national bulk carrier, IR has to find ways and means to source energy through most economical means and to encourage meeting national objectives of decarbonising the transport sector.

The Electricity Act, 2003 saved Railway Act and thereby provided deemed distribution licensee status to Railways, leading to it being treated at par with Discoms. Thus, IR can directly buy content (energy) from generators and after paying for haulage (wheeling) charges over central and state transmission system, consume it over its network. Availability of deemed licensee status to Indian Railways under Electricity Act, 2003, opened this opportunity. Realizing the potential of saving in traction power bill through open access Hon'ble Minister of Railways Sh. Suresh Prabhu took up the challenge for operationalization of deemed distribution licensee status for Railways. With his long background of Power sector, he pursued this issue with vigour (it is providential that the architect of Electricity Act, 2003, now leads Ministry of Railways).

Having done exhaustive background work, the promise and enthusiasm was shared by the Hon'ble Minister of Railway in Budget Speech of 2015 as under:

"It is proposed to procure power through bidding process at economical tariff from generating companies, power exchanges, and bilateral arrangements. This initiative is likely to result in substantial savings of at least ₹ 3,000 crore in next few years".

Despite apprehensions, under able guidance of Sh. Suresh P Prabhu, Hon'ble Minister of Railways, a strategy was worked out and a

power purchase agreement with Gujarat generation companies for consumption of power in Maharashtra was entered. To invoke Indian Railways status of deemed licensee status (as duly clarified by Ministry of Power in May'14) under provisions of Indian Electricity Act an application for issuing NOC was made to State Load Dispatch Centre (SLDC) in Maharashtra in Jan.'15. However, Maharashtra raised certain issues regarding distribution licensee status of Railways. Based on further guidance from Hon'ble Minister of Railway Sh. Suresh Prabhu, Railways approached Central Electricity Regulatory Commission (CERC) to get these issues clarified. In a historic order CERC on 5th Nov.'15, after duly taking into account all existing orders including the Hon'ble Supreme court order in cases between Ministry of Railway, and looking at the fact that Railways Act has been duly saved in Electricity Act, clarified that Ministry of Railways have status of deemed licensee and can arrange power for its own use as distribution company.

Indian Railways simultaneously contracted for about 500 MW power from Ratnagiri Gas Power Private limited (RGPPL) for consuming it in states of Maharashtra, Gujarat, M.P. & Jharkhand. On basis of this order, fresh NOC application was made to state of Maharashtra for drawing about 200 MW power at 47 Traction sub stations, covering Central and Western Railways. With flow of this power from 26th Nov.'15, Indian Railway's long cherished dream to avail power as Deemed Licensee saw light of day. This became possible due to vision, direction & guidance by Hon'ble Minister of Railway Sh. Suresh P. Prabhu. This is first time that Railways have started drawing power under open access as deemed licensee using State transmission network. This 200 MW power in Maharashtra is resulting in saving of about ₹ 600 crore per

annum (saving @ about ₹ 3.5 per unit for about 1.8 Billion units = about ₹ 630 crore). After success in Maharashtra, NOC applications were made in other three states i.e., MP, Gujarat and Jharkhand. After vigorously pursuing the matter in these three states, NOCs were extended by SLDCs of these states. Based on these NOCs 200 MW power in MP, 90 MW in Gujarat and 80MW in Jharkhand started flowing in all these states since 22th Jan.'16.

With this an important Rail Budget 2015-'16 commitment, to reduce input cost to railways by ₹ 3,000 crore through procuring power at economical tariff was realized.

Challenges faced

For IR, to get connected as Deemed Distribution Licensee, it was a real challenge as process of getting No-Objection Certificates was not easy. However, due to collective efforts of Ministry of Power and Ministry of Railways, Government of Maharashtra, M.P., Gujarat and Jharkhand, progress could be made. Some of the challenges faced in obtaining NOC for drawing power as Distribution Licensee were:

- i. Provisioning of ABT meters (Availability based meters)
- ii. Ensuring metering CT/PT (Current transformer/Potential transformer) of correct class.
- iii. Obtaining clearances from DISCOMs
- iv. Working out with SLDC deviation settlement mechanism (DSM)
- v. Sorting out issues related to provision of backup power
- vi. Developing a reasonable accurate day ahead load forecasting mechanism looking at variable demand of Railways.
- vii. Convincing Railways that any disruption in power will not affect Railways operation as in that case power will be available from the grid.

viii. Convincing state government that in long term it is win situation.

In addition to above, Railways through its company namely REMCL (Railway Energy Management Company Limited) contracted 50 MW power through open tendering system using Ministry of Power 'case one' bidding document @ ₹ 3.69 per unit in its Central Transmission Utility (CTU) connected network from Dadri to Kanpur in U.P. This 50 MW power started flowing from 1st Dec.'15. This probably was first time that any organisation contracted power through 'case one' bidding document of Ministry of power. With these actions average cost of electric traction has come down to ₹ 4.61 per unit in these five States from earlier average of ₹ 7.70 per unit. This has started giving a saving of about ₹ 1,300 crore on annualized basis to Railways and in financial year 2015-'16, reversed the increasing trend of cost of power by bringing down traction bill to ₹ 10,406 crore (for FY 2015-'16) as against bill of ₹ 10,436 crore for 2014-'15 inspite of increase in power consumption to cater to increased traffic.

This is a classic example of co-operation between Central and State agencies, where they have worked shoulder to shoulder. This move will also benefit states in due course of time as it will lead to shift of traffic from road to rail thereby reducing pressure of State Road Network.

Implications of New Traction Power Procurement Strategy

After success of procurement of power through open access in 2015-'16, Hon'ble Minister of Railways in Budget Speech 2016 announced:

"In my Budget Speech last year, I had promised annualized savings of ₹ 3,000 crore to be achieved by the third year. It is about 30% of total traction supply cost. I am happy to announce that the target will be achieved in the next financial year itself, a year earlier than envisaged. For the first time, IR has leveraged provisions of Electricity Act to

procure power directly at competitive rates, using its status as Deemed Distribution Licensee. Power Procurement Contracts already signed and implemented will mean an annualized saving of ₹ 1,300 crore. Further actions to source power, already initiated, will deliver annualized savings of ₹ 1,700 crore during the coming year, taking the total to ₹ 3,000 crore. In addition, the saving of ₹ 3,000 crore is being targeted through demand side management and energy efficiency measures".

Paraphrasing JFK when he announced intent to go on the moon, setting a ten year target- "We want to do it, not because it is easy, but because it is difficult. The target was beaten".

Operationalisation of deemed licensee status has given unprecedented opportunity to Railways to reduce its high rate of traction power cost, which is a key variable cost. Its reduction has wide implications on financial viability of Railways. After successfully taking

traction power through open access mechanism in states of Maharashtra, Gujarat, M.P., Jharkhand and U.P., it has been established that there is potential of substantial savings through this route., Indian Railways, accordingly, through its company REMCL, tied-up about 585 MW power through open tender from Jindal India Thermal Power Ltd. (JITPL) for states of Orissa, Bihar, U.P., Punjab, Haryana, Delhi, Rajasthan and Chhattisgarh at an average rate of around ₹ 4.00 per unit at consumption point (traction sub-station-TSS). In addition 50 MW power has been tied up in West Bengal for short term from DVC till such time power is available from Railways captive power plant at Nabinagar (BRBCL) at rate ₹ 3.69 per unit at CTU point. Further to it for Southern States (TN, AP, Telangana & Karnataka) about 400 MW power has been tied up by REMCL at an average rate of about ₹ 5.00 per unit. Comparison of rates because of each of these initiations in indicated below.

Savings achieved in contracts already negotiated indicate savings possible

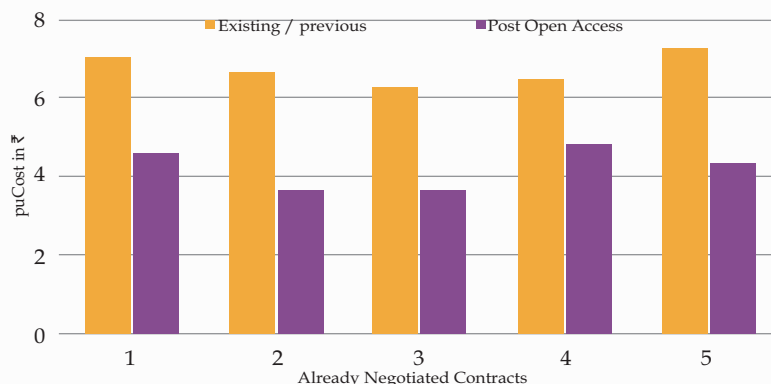

Captive power Generation

In addition Railways own captive power plant at Nabinagar being developed by BRBCL (Bhartia Rail Bijil Company Limited) is also now taking shape with its first unit getting commissioned on 30th Mar.'16. This first unit of 1000 MW plant is expected to provide 'firm power' from Sep.'16. Railways will be availing 90% power from this plant and 10% will be available to Bihar State.

All these initiatives are likely to provide a saving of about ₹ 3,000 crore per annum in traction bill. In the BAU mode traction tariff would have continued to grow @ about 5% per annum and whereas because of adoption of market driven strategies along with availing Deemed Licensees status the cost has come down substantially. Accordingly, total saving will works out to ₹ 4,000 crore per annum against Business as Usual (BAU).

Current Status

To generate these savings in the Electric traction bill to the tune of ₹ 3,000 crore/year over 2014-'15 bills following actions have been initiated.

- ₹ 1300 crore/year savings already been achieved with **730 MW** power from **RGPPL** (above 550 MW), **Adani** (50 MW contracted through open tender), **Tata Power** (80 MW), **NTPC** (50 MW). Average rate reduced from ₹ 7.07 to ₹ 4.61/unit i.e., saving of ₹ 2.46/unit. [Covered 100% power in four states (Maharashtra, Gujarat, Madhya Pradesh and Jharkhand - 630 MW at 114 TSS) and at CTUs connected network in UP (100 MW at 14 TSS)]
- Saving of ₹ 1100 crore/year will be achieved by additional about 500 MW Power already tied up with M/s Jindal India Thermal Power (JITP) through open tender. Average rate will reduce from ₹ 6.5 to ₹ 3.7/unit i.e., saving of ₹ 2.8/unit.
- Further a tender for procuring about 400 MW for southern states has been finalized by REMC. This will save ₹ 400 crore/year. Average rate will reduce from ₹ 6.5 to ₹ 4.9/unit i.e., a saving of ₹ 1.6 per unit. This will cover 87 TSS in states of Tamil Nadu, Telangana and Andhra Pradesh.
- Nabinagar captive power plant of Railway is now ready and from its first unit is now scheduled to supply power from Sep.'16. It

will save ₹ 200 crore/year. First unit of 250 MW was commissioned on 23rd Mar.'16, and firm power expected from Sep.'16. Average rate will reduce from ₹ 7.3 to ₹ 4.4/unit i.e., saving of ₹ 2.90/unit. (first unit will cover 26 TSS in West Bengal)

With these actions it is expected that by 2017-'18 savings of ₹ 4,000 crore/year will accrue as against the business as usual mode - (Considering effect of annual tariff increase, increase in traction energy requirement etc.). Speedy electrification of existing tracks and commissioning of DFCCIL network in coming days, will add to increased saving for Railways.

Savings will also accrue due to improvement in Specific Energy Consumption (SEC), due to induction of Energy Efficient Locomotives capable of regenerative braking (converting kinetic energy of train to usable electricity).

Saving Projections

Considering drawing of electric traction power through open access with an average cost of power at ₹ 4.50/unit, an estimate of savings upto 2025 are expected to be about ₹ 35,000 crore as indicated below.

This savings has been considered against the business as usual mode (considering a tariff growth of 4.81% based on rate of growth of traction power cost of previous years). These savings are expected to increase further, on operationasation of DFCCIL.

Saving Senario

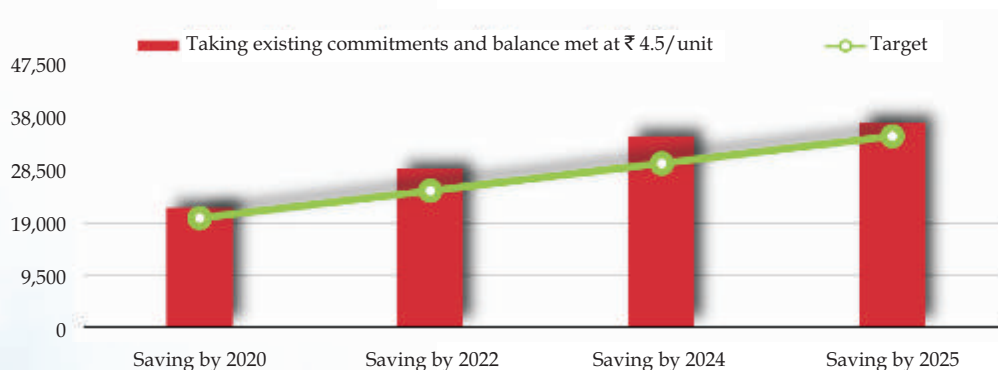

It is expected that with induction of more three phase Locomotives and EMUs, energy savings potential on account of regeneration, (which is about 20% for locomotives and about 30% for EMU stock), will further contribute to saving by 2025. These figures have taken into account expected upward pressure on thermal

electricity with new emission norms coming into force. It can safely be said that by 2025 these actions to procure power directly from the market, Railways will be able to save about ₹ 35,000 crore during 2015-'25 on cumulative basis.

Break up of cumulative saving of ₹ 35,000 crore

| Year | Payment in Business As Usual (BAU) ₹ (crore) | Payment in new Paradigm ₹ (crore) | Savings ₹ (crore) | Cumulative saving ₹ (crore) |
|----------|--|-----------------------------------|-------------------|-----------------------------|
| | 10600 | 7091.72 | 3508.28 | 3508.28 |
| 2016-'17 | 11580.25 | 7225.18 | 4355.06 | 7863.34 |
| 2017-'18 | 12137.15 | 7553.64 | 4583.51 | 12446.86 |
| 2018-'19 | 12720.85 | 8257.94 | 4462.9 | 16909.76 |
| 2019-'20 | 13332.61 | 8352.93 | 4979.68 | 21889.44 |
| 2020-'21 | 13973.79 | 10338.23 | 3635.56 | 25525.00 |
| 2021-'22 | 14645.81 | 11235.17 | 3410.64 | 28935.64 |
| 2022-'23 | 15350.15 | 12190.71 | 3159.44 | 32095.08 |
| 2023-'24 | 16088.36 | 13207.74 | 2880.62 | 34975.70 |
| 2024-'25 | 16862.07 | 14308.23 | 2553.84 | 37529.54 |
| 2025-'26 | 17672.99 | 15520.2 | 2152.79 | 39682.33 |

Key take away

Limited runs of new strategy of traction electricity procurement from market as deemed distribution licensee, though open access, has shown path towards substantially bringing down cost of Electric traction power for Indian Railways. By adopting this method of procurement of power Indian Railways have broken the business as usual mode and has entered into new era in handling its power requirement. It will open various vistas to manage this power requirement in a dynamic fashion taking benefit of low cost power available through power exchange, short term

contracts etc. This will bring in factor of innovation in power procurement in Railways and will change the way people have been working in Railways. This innovation will expose Railways to the power sector which is a dynamic world and is taking shape with change in energy mix from conventional to Renewable energy sources. It can be readily seen that deployment of WWS (Wind, Water, Solar) based electricity can't be done gainfully unless mechanism of open access is exercised, wherein, electricity is evacuated from the WWS surplus zones to other regions-this is common economic practice.

Way ahead

Having come thus far, lessons have been learnt and are being internalized.

Use of market mechanisms can be a double edged sword. To fully utilize the benefits available and to save against risks there is a need to have elaborate technology platform to give confidence to the grid operators that IR's connectivity meets all statutory requirements of Indian Electricity Grid Code-2010. A well designed system will deliver consistent and optimized savings. Accordingly, there is a need to have robust nationwide Command, Control and Forecasting system, which are highly optimized for realtime control and monitoring with energy management functionality.

Conclusion

To improve Indian Railways financial viability, reversing fuel bill trend was an important goal, as it constituted about 30% of ordinary working expenses. In this regard, realizing the potential

under deemed licensee status, available to Railways was first land mark achievement of Railways which reversed the increasing trend of electric traction bill of Indian Railways. In **2015-'16**, with these initiatives annualized **savings of ₹ 1,300 crore** was achieved and it is expected that taking forward further actions in this area will take annualized **saving** of about **₹ 3,000 crore** during **2016-'17**.

Impact of procuring power as Licensee will bring in **saving** of more than **₹ 4,000 crore per annum** against the Business as Usual (BAU) approach. Its effect on Railway finances over next 10 years will be more than **₹ 35,000 crore** and will add to making Railways a more viable mode of transport.

As a snowball effect **Diesel** procurement system is also being revamped and by **procuring crude oil directly** it will generate a saving of about **₹ 1,500 crore per annum** in coming years. All these actions will make it possible for Railways to become a modern high speed passenger friendly mode of transport.



Decarbonization of IR's Energy Needs - Power through Wind & Solar Plants



"If you are in the luckiest one percent of humanity, you owe it to the rest of humanity to think about the other ninety-nine percent"

---Warren Buffet

Why Decarbonise

Climate change mitigating action rests on reducing carbon footprint of economic activities. Recently concluded COP21 in Dec.'15, has brought together 195 countries with an objective of reducing global warming. Global warming is attributed to emissions of green house gases (GHG). Global warming is measured in terms of global warming potential (GWP) of CO₂. Hence there is an increasing pressure on all countries to reduce emissions while maintaining their levels of economic growth. Developing countries like India, increasing economic activity, create employment and at same time reducing the emissions is utmost priority.

Hence there is a need to reduce energy intensity (indicator of energy needed to support a unit of GDP), and also to reduce carbon footprint of our economic activities.

Why Electrified Transport

It is a settled fact that decarbonisation of electrical energy demand is comparatively straight forward than decarbonising non-electrified energy demand, as electrical energy is neutral to primary energy source. **Two-thirds of freight** and little over **half of passenger traffic** on IR is moved on **electric traction**. Modal share of rail vis-à-vis road being, less than a third for freight and less than 15% for passenger transport. Road transport would continue its dependence on imported liquid fuels and hence a switch cannot be easily made. Whereas, **electrified railway** offers **shortest** and most **energy efficient** route to **decarbonizes** transport.

Electrical energy demand can be decarbonized using clean power sources such as - solar, wind, hydro, and waste to energy. Decarbonized electricity is key thrust area of government, with renewables on top of Hon'ble Prime Minister's agenda in his meetings with first world leaders. Access to clean technologies is key component of Indian foreign policy.

Mechanisms can be evolved, deploying open access to apportion and create access to electricity generated from the renewable resources, thereby enabling a swift decarbonisation of IR's energy needs.

Renewables in IR

Railway operations are energy intensive and provisions of Electricity Act, 2003 give possibilities of decarbonising the energy basket. 36.5 MW of wind generation is already feeding railways' electricity requirement. In addition, 14 MW of solar is in operation and 50 MW is under different stages of commissioning. Railways are working to take this capacity to 1000 MW of solar power by 2020.

By their very nature, railway stations, maintenance facilities, office buildings, sufficient untapped space exists to implement solar generation. All this rooftop capacities will be used. Reuse of released coach batteries can be a game changer for storage solutions for smaller locations to avoid and use of Diesel Generator sets.

Decarbonization of IR

Because of volume of IR's energy consumption, prioritizing decarbonization of Indian Railways could help India achieve its 2030 emissions reduction goals as well as improve energy security by reducing fossil fuel imports. In addition, decarbonization may be a more cost-effective option for IR in the long run. To showcase potential of investment in Indian Railway to make it 100% decarbonisation with sustainable electrification, Institution of Railways Electrical Engineer (IREE) has organized an International Conference on "Decarbonization of IR -Mission Electrification" on 3rd Nov.'16, in New Delhi. This conference also aimed for giving boost to Make in India and Innovative India campaigns of Hon'ble Prime Minister. This conference will also be a small step towards accomplishing the target of **175 GW renewable energy** including **100 GW solar energy by 2022**.

International Conference on Decarbonization of IR & Mission Electrification



Solar Energy

As part of Indian Railway's Solar mission and to reduce dependence on fossil fuels, keeping in line with Budget (2015-'16) announcement of Hon'ble MR, Railways plan to set up 1000 MW solar power plant in next five years (by 2020). As part of this, IR will setup solar power plant on rooftops of Railway stations, buildings and on Railways land as under:

- **500 MW** solar plants on **roof top** of Railway buildings through developer mode with PPA by Railways, which will be used for meeting **non- traction power** supply loads.
- **500 MW** solar plants to be put up on **land based** systems with PPAs to be signed by railways with developers, primarily to meet **traction power** supply.

Indian Railways started putting up solar power plants in 2014-'15, on administrative buildings, stations & hospitals. Harnessing of solar energy was enhanced in following year taking total capacity to about **14 Mega Watt (MW)** by **2015-'16**.

This includes **one MW solar power** plant on rooftop of **Katra Railway** station. Further to it order for 6.5 MW solar power (five locations each of 500 kWp, 20 locations each of 100 kWp, 200 locations each of 10 kWp) has issued. The mechanism available under Electricity Act, 2003, this power can be consumed in railway grid-paving way to steady decarbonization of Indian Railways.

Photographs of some of solar power plants set up by zonal railways are shown below:





500 kWp Solar rooftop power plant at Varanasi Railway Station



500 kWp grid connected Solar rooftop power Plant at Secunderabad Station



Solar rooftop power plant at Jaipur Railway Station

To harness solar energy on large scale, Zonal Railways under phase-I, have been allocated installation of **50 MW** capacity. These plants will be installed by **Jun.'17**. Further to it, Zonal Railways have identified additional capacity for installing 100 MW solar power on roof top. REMCL shall invite tenders for same. For all these rooftop installation Viability Gap Fund (VGF) from Ministry of New Renewable Energy (MNRE) has been provided. Further tenders for rooftop installations will be floated in a phase manner for additional 350 MW under MNRE's incentive scheme and consultancy work is given to M/s Central Electronics Limited (CEL) for assessing capacity. Harnessing total expected capacity of about 500 MW on rooftop for Railway Buildings.

Following actions have been taken for installation of 500 MW solar plants on land systems:

1. 50 MWp is been set up for meeting Railways needs through Reva Ultra Mega solar Limited (RUMS) in M.P.
2. 40 MW will be setup through Solar Energy Corporation India (SECI) for traction load with battery backup (30 minutes) as per MNRE special scheme.
3. 150 MW solar power will be setup through SECI for meeting non traction power requirement.
4. For balance about 250 MW Railway Energy Management Company Limited (REMCL) will be working out various options.

Following graph shows plan of deployment of solar generation: As can be seen that initially rooftop projects are taken to create needed momentum for the project.

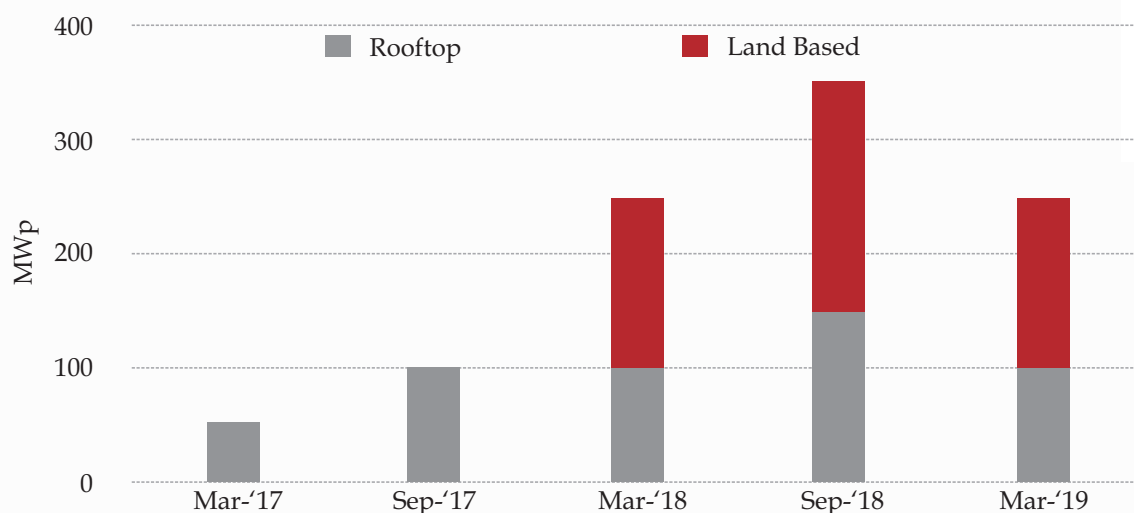

For development of different types of Renewable Energy Technology Projects on Indian Railways like (off grid/grid connected like solar panel) etc. on Railway coaches & other Rolling stock, stations, innovative use of vacant Railway spaces etc in field of Solar, Wind & Hybrid or waste to electricity or any new types of applications/installations or any other application suitable for Railways, An Memorandum of Understanding (MoU) has

been signed between Ministry of Railways and Ministry of Science & Technology on 2nd Nov.'16 at Railway Board, New Delhi for collaboration in efforts for developing & utilization of Renewable Energy Technologies like solar energy in Indian Railways as Government of India (GoI) has identified power sector as key to achieving the goals of sustainable economic growth.

MoU Signing between Ministry of Railways & Ministry of Science & Technology



Harnessing Wind power for Railways

Indian Railways has planned to set up **192.5 MW of wind mill power plants**. Out of this 10.5 MW capacity wind mill plant has already been set up in Triunelveli Distt. Tamil Nadu for meeting energy demand of Integral Coach Factory (ICF), Chennai. This mill has generated 127.69 million units till Mar.'16. Further **26 MW windmill power** plant was commissioned in **Oct.'15 in Jaisalmer, Rajasthan** through Railway Energy Management Company Limited (REMCL) and this wind mill has generated more than 60 lakh units since then. Further to it, the installation of balance capacity is planned through tariff based bidding and partly through Railways investment (through REMCL).

These capacities will be created based on requirement of non-solar RPO obligation in various states. IR is planning to install 56 MW wind mill through tariff based bidding for non-traction load in Maharashtra, Andhra Pradesh, Tamil Nadu and Madhya Pradesh states and 100 MW Wind Mill plants shall be taken by REMCL.

Conclusion

India currently stands at a moment of opportunity in which it is evident that transitioning to low-carbon systems can bring about economic growth. Falling costs of renewable energy, ambitious government plans for rapid deployment of renewable energy, and increasing financial support from international governments and investors all indicate that transition to a low-carbon economy is not only possible, but already underway. As IR is the single largest consumer of electricity in India, consuming about **18 billion kWh per year**, or roughly **2%** of country's total power generation, prioritizing decarbonization of Indian Railways could help India achieve its 2030 emissions reduction goals as well as improve energy security by reducing fossil fuel imports. Targeting 100% decarbonization of IR, is a strategic example for the transportation sector as well as to Indian industry as a whole. As part of this strategy IR has planned to set up **1000 MW solar power** plant and **192.5 MW** of wind mill power plants in next five years (by 2020) across Zonal Railways & productions units.

7

Future Initiative

Electrical Development Directorate

Policy enabling provisions made - Make in India

Following projects have potential of 'Make in India' proposition and attract FDI in Rail Sector. Update status of these projects are as under:

1. Setting up of Electric Loco Manufacturing Factory at Madhepura in Bihar (A Make in India Project):

Project was awarded to Alstom Manufacturing India Ltd on 9th Nov.'15 following a transparent International Competitive Bidding (ICB). Contract agreement was signed on 30th Nov.'15 between Ministry of Railways and Madhepura Electric Locomotive Private Limited (MELPL), a Joint Venture (JV) company of Ministry of Railways and Alstom Manufacturing India Limited. Land required for the project has been

provided to MELPL through a Land Lease Agreement signed on 8th Mar.'16. Land License Agreements for Company Depot at Saharanpur and Government Depot at Nagpur have also been signed. MELPL has started work for construction of the factory and maintenance depot.

Total 800 nos of state of art 12000 hp locomotives would be supplied to IR against long term procurement cum maintenance contract which also envisages comprehensive maintenance of a part of supplied locomotives to establish life cycle costing. These locomotives will be primarily used to haul trains on Eastern DFC. The project is also expected to bring in a paradigm shift in maintenance philosophy of locomotives in IR. Regenerative braking feature using IGBT technology is expected to reduce 500 tonnes of CO₂ emission per annum per loco.



12000 HP Electric Locomotive

(2) Rail Coach Factory at Kanchrapara/ West Bengal:

IR has taken initiative to set up Greenfield EMU/MEMU factory at Kanchrapara, for manufacturing 5000 EMU/MEMU cars over a period of 10 years. MEMU trains supplied against this project will help replace existing slow moving loco-hauled passenger trains with 3-phase IGBT based MEMU trains. Regenerative braking feature using IGBT technology is expected to reduce 600 tonnes of CO₂ emission per annum per train (12 Cars).

As part of two stage bidding process, Request for Qualification (RFQ) applications were opened on 15th Sep.'16. Bidders have been shortlisted for participation in the RFP stage.

(3) 9000 hp Electric Locomotives for DFC:

Two hundred nos. 9000 HP IGBT based locomotives have been planned for procurement primarily for hauling double stack container traffic on Western DFC.



Future 9000 HP ELECTRIC LOCOMOTIVES

4. Procurement-cum-Maintenance of EMU Tran Sets: (15 Sets-315 Cars; out of 315 Cars 40 could be imported and 275 to be Made in India).

Special Feature

- Ergonomically designed interiors
- Aircraft like comfort
- Jerk less travel due to distributed monitoring
- Noiseless
- On board infotainment system
- Multi coloured on board display system
- On board surveillance camera
- Individual AC control
- Aircraft type pantry
- Reduced journey time by 20%
- Save Energy
- Reduced noise and air pollution

Electric Trains (Interior)





5. Electric Loco Assembly & Ancillary Unit of CLW at Dankuni in West Bengal:

IR has taken initiative to set up Electric Loco Assembly and Ancillary Unit of CLW at

Dankuni. Construction of the unit has been completed and Assembly of Electric Locomotives has been started. First Electric Locomotive has been rolled out from this unit on 8th Mar.'16.





6. Upcoming Initiatives

In order to keep abreast with latest technological development and ensure energy efficient operation Indian Railways has taken initiatives to indigenously manufacture IGBT technology based state of art locos, EMUs, MEMUS and train set as listed below:

- Railways have taken decision to introduce state of art Kolkata Metro rakes with three phase propulsion system with regenerative braking. In this regard an order for procurement of 14 fully furnished rakes for Kolkata Metro with IGBT based propulsion system and regenerative braking system has been placed on M/s Dalian, China. Further two rakes with indigenous development of three phase propulsion system with regenerative braking are under manufacturing at ICF.
- Energy efficient EMUs rakes having three phase propulsion system with regenerative braking system are also planned to be

introduced in other than Mumbai area. Integral Coach Factory (ICF), Chennai has initiated the tender for procurement of propulsion system for manufacturing of 33 rakes of 12 car EMUs at ICF.

- Manufacturing of energy efficient MEMU rakes with three phase propulsion system and regenerative braking are also planned at Rail Coach Factory (RCF). Procurement of three phase propulsion system of 10 MEMU rakes is under process.

7. Green Initiative:

As part of project for Improving Energy Efficiency in Railways residential quarters, about 1.4 million incandescent bulbs were replaced by energy efficient CFLs at no additional cost to Railways under Clean Development Mechanism (CDM) of UNFCCC.

Till date total 3,15,395 nos of Certified Emission Reductions (CERs) have been issued by UNFCCC in favour of this project.



MINISTRY OF RAILWAYS
Railway Board
Rail Bhawan, New Delhi