

Automotive Air Conditioning Training Manual

**How Automotive Air Conditioning Works?
Automotive Air Conditioning Components Description
Service Equipment
Air Conditioning Performance Testing**



Theory	3
History	
Understanding Heat	
How does heat get inside a vehicle?	
What causes heat to move?	
Basic physics of air conditioning	
Evaporation	
Condensation	
Pressure & temperature relationship	
Refrigerants in Automotive Air Conditioning Systems	
How Automotive Air Conditioning Works	7
Expansion Valve System	
Orifice Tube System	
A/C Components Description	9
Compressor	
Condenser	
Evaporator	
Thermal Expansion Valves	
Orifice Tube	
Filter Drier Receiver	
Accumulator	
“O” Rings	
A/C Lines and Hoses	
Charging Ports	
Manual temperature control (MTC)	
Automatic Temperature Control (ATC)	
A/C Service Equipment	27
Refrigerant Recovery & Recycling Equipment	
Evacuation Equipment	
Charging Equipment	
All in One Unit – Automatic A/C Service Station	
A/C Flushing Equipment	
Leak Test & Detection Equipment	
Other Measuring Instruments	
Universal Automotive A/C Tools	
Universal A/C Assortments	
Compressor Oil	
Refrigerant Safety	
R134a – HFO 1234yf Handling and Service Differences	
Air Conditioning Performance Testing (General)	41
Pressure gauges	
Pressure gauges readings in normal condition	
Faulty performance of A/C system	
Troubleshooting and Solutions	

Theory

Air conditioning system in a vehicle is a part of HVAC system which allows adjusting of air temperature, humidity, and direction. It also improves the air quality, which may benefit people with certain health problems, by dehumidifying and cleaning the air as it cools it.

To be effective, the automotive air-con system must control four (4) conditions within the vehicle interior:

- It must cool the air
- It must circulate the air
- It must purify the air
- It must dehumidify the air

History

A company in New York City in the United States, first offered installation of air conditioning for cars in 1933. Most of their customers operated limousines and luxury cars.

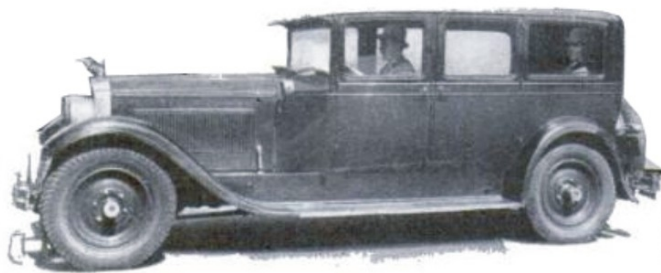

Through the grills above, fresh air enters and old air is expelled in the first air-conditioned car seen above.

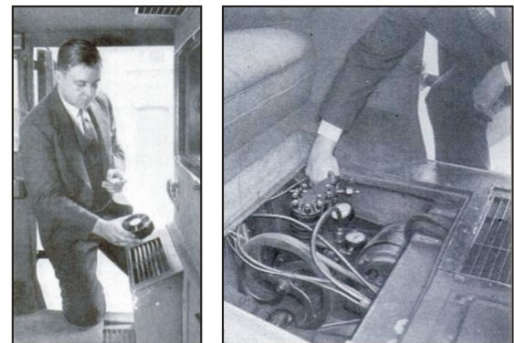

The Packard Motor Car Company was the first automobile manufacturer to build air conditioners into its cars, beginning in late 1939 (at the start of the 1940 model year). Packard ran its advertising as, "*Forget the heat this summer in the only air-conditioned car in the world*".

The 1953 Chrysler Imperial was the first production car in twelve years to actually have automobile air conditioning. It was high capacity unit available on an automobile. It was also simple to operate, with a single switch on the dashboard with low, medium, and high positions. The system was capable of cooling the car and of completely eliminating humidity, dust, pollen and tobacco smoke at the same time.

The innovation was adopted quickly, and by 1960 about 20% of all cars in the U.S. had air-conditioning, with the percentage increasing to 80% in the warm areas of the Southwest.

By 1969, 54% of the U.S. automobiles were equipped with air conditioning, with the feature needed not only for passenger comfort, but also to increase the car's resale value.

In a 1971 front-page story, the *New York Times* implicated air-conditioning in the death of the convertible, postulating that: "In the age of air-conditioning, real air has lost its value."

After the R12 refrigerant used in A/C units was blamed for depleting the ozone layer, automakers were required to switch to the less harmful R134a refrigerant by 1995.

Dual-zone automatic climate control allows for separate temperature settings for driver and passenger; some cars have additional zones for rear-seat passengers.

Volkswagen calls its automatic controlled air-conditioning system "Climatronic."

99 percent of all new cars in 2010 are air-conditioned.

First vehicles with new refrigerant HFO-1234yf developed to meet EU directives, which demand a refrigerant with a GWP of less than 150, appears on the market in 2012.

Understanding Heat

For a simple definition we may say that **heat is energy**. Meshing of gears, or turning of wheels cause friction which results in heat. Combustion (fire) gives off heat. The burning of sun radiates heat to the earth's surface. Heat in the correct amount will provide life and comfort. Heat in either extreme - extreme too much or too little - will be uncomfortable. The control of temperature means the control of comfort. Air conditioning is a method of controlling heat.

All substances contain heat. Science tells us that a measurement called "Absolute Zero" is the point at which all heat is removed from an object (approximately $-273\text{ }^{\circ}\text{C}$). Any substance above this absolute zero temperature retains some heat.

The average person requires a comfort zone of approximately 21°C to 26°C , with a relative humidity of 45 to 50%. In this temperature and humidity range, we feel most comfortable. All objects within this same range are comfortable to touch. As the temperature of anything goes above or below this range, we think of it as HOT or COLD.

How does heat get inside a vehicle?

When a car is driven or parked in the sun, heat enters the vehicle from many sources: Ambient air, Sunlight, Engine heat, Road heat, Exhaust heat...

All of these and other miscellaneous heat sources increase the air temperature within the vehicle. In a high ambient temperature situation (e.g. on a 37°C day), the interior of a vehicle left standing in the sun with windows closed could **reach $65\text{-}70^{\circ}\text{C}$** .

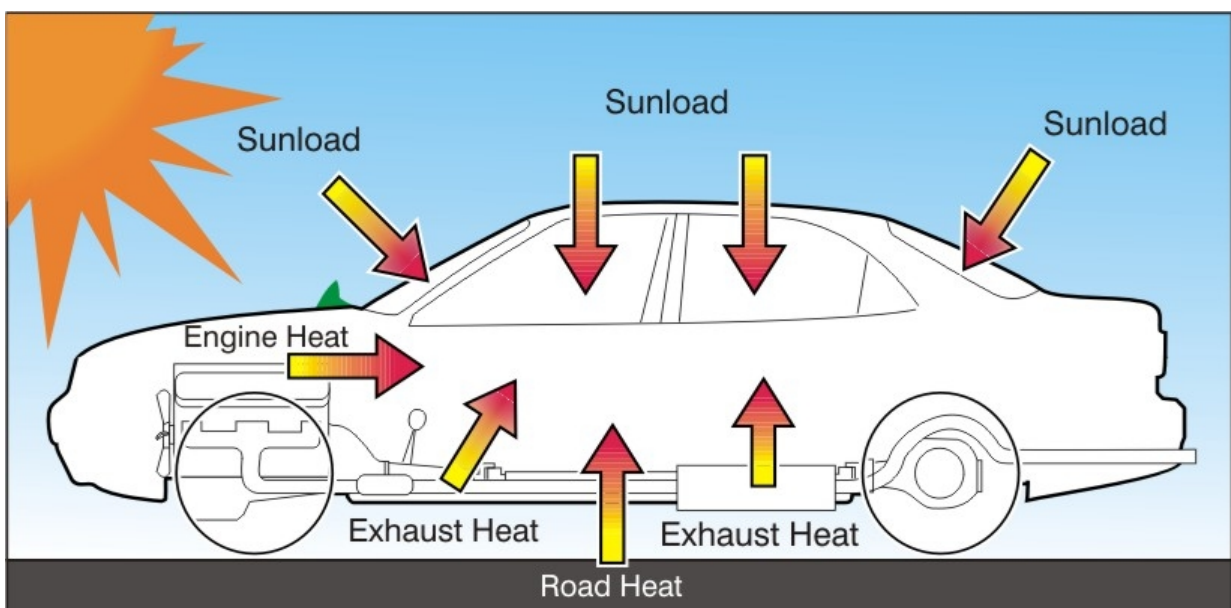

What causes heat to move?

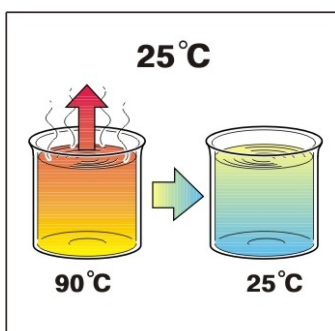

Heat always moves from the hotter objects to the colder one. Whenever there is a transfer difference between two objects, the heat energy will be transferred from the warmer object to the cooler one until both objects stabilize at the same temperature.

This is the basis of air conditioning operation. Automotive air conditioner is designed to move heat from one place (the inside of your car) to some other place (the outdoors).

When a hot cup of coffee is set aside for some time, it becomes cold. Heat moves out of the hot (90°C) coffee into the cooler (25°C) surrounding air. In time the coffee will reach the temperature of the surrounding air.

Basic physics of air conditioning

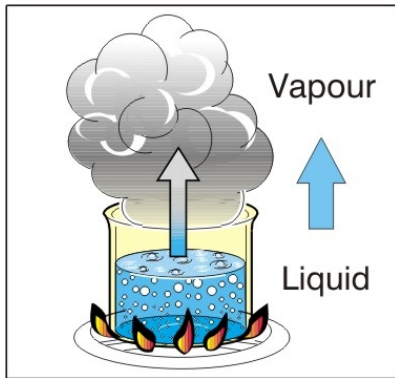

Evaporation

Is the term used when enough heat is added to a liquid substance to change it into a vapour (gas). For example, when water is boiled.

This condition occurs within the A/C system, only the refrigerant is evaporating.

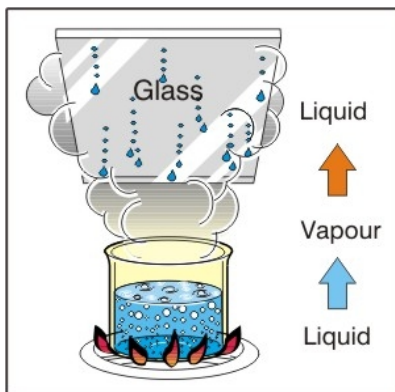

Condensation

Is the term used to describe the opposite of the evaporation process. If you take a vapour and remove enough heat from it, a change of state occurs. The vapour becomes a liquid.

The change of vapour to a liquid is called condensation.

This condition occurs within the A/C system, only the refrigerant is condensing.

Pressure & temperature relationship

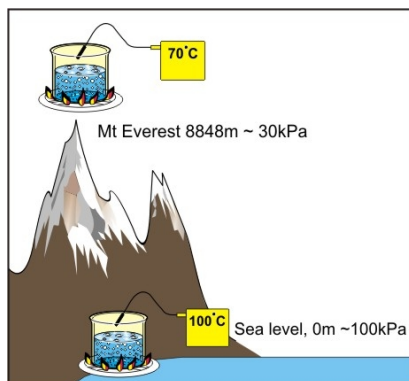

To increase or decrease the boiling point of a substance, we must alter the pressure on the substance.

**Increasing the pressure increases the boiling point.
To decrease the boiling point, decrease the pressure.**

Example:

At sea level atmospheric pressure ~ 100 kPa boiling point of water is 100°C . On Mt. Everest (~ 30 kPa) boiling point is 70°C .

Water in a vacuum will boil at 19°C .

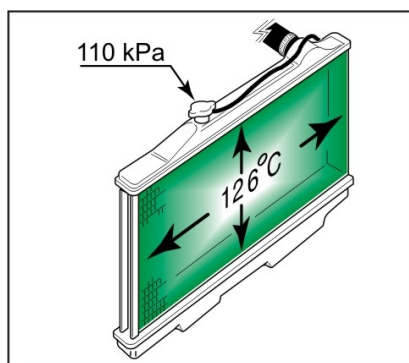

If water is put under pressure, the boiling point will rise. Good example is the automotive cooling system. The pressure cap keeps the radiator from boiling over by increasing the pressure on the coolant.

Example: 110 kPa radiator cap allows the coolant temperature to reach 126 C before boiling.

The same holds true for the refrigerants used in an air conditioning system. Under pressure the boil point is raised, when pressure is lowered the boil point is lowered.

Refrigerants in Automotive Air Conditioning Systems

Refrigerant is a fluid capable of changes of its state at low temperatures. Released on atmospheric pressure refrigerants used in automotive industry will boil at ~ 26 °C, changing its state from liquid to vapour (evaporate). In the process of evaporation they absorb large quantity of heat from surrounding (in our case the heat from inside the vehicle).

Automotive refrigerant has changed over the years from ammonia gas, to R12 (Freon), to R134a and now to 1234yf.

Since 1990's the Automotive industry has started to use a non-ozonex-depleting refrigerant **R134a (HFC)** which was selected as a replacement for old **R12 (CFC)** because is has a major effect to ozone layer depletion.

R134a lives for around 13 years in the atmosphere before breaking down. Its global warming potential (GWP) is ~1400.

HFO1234yf is a new refrigerant, developed for auto air conditioning as a replacement for R-134a. It was developed to meet EU directives, which demand a refrigerant with a GWP of less than 150. New refrigerant 1234yf breaks up in around 11 days, with GWP of 4.

HFO-1234yf has a pressure-temperature curve and other key characteristics very close to R-134a. It is thermally stable and compatible with R-134a components, and would be a near drop-in replacement for R-134a. A drop-in test by Toyota showed HFO1234yf had slightly better cooling performance than R-134a.

R134a probably will not disappear till 2025 year. Vehicles produced from 1990 to 2015 will still need R134a. What is to expect that the R134a price will go up which will prevent frivolous use.

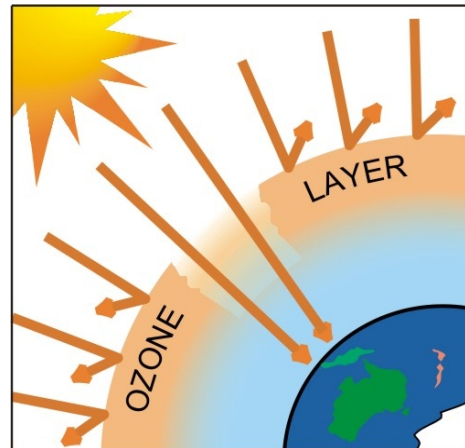

Ozone layer acts as a shield that protects the earth's surface from harmful ultra violet radiation coming from the sun. Since R12 was phased out in the holes in the ozone layer have been healing themselves.

	R12 (in use till 1990)	R134-a (in use 1990-2016)	1234yf (in use from 2012)
Chemical name	(CFC) ChloroFluoroCarbon	(HFC) HydroFluoroCarbon	HFO HydroFluoroOlefin
Ozone depleting potential (1=max)	1.0	0	0
Global warming potential (GWP)	2400	1400	4
Boiling point on atmospheric pressure	-29.6 °C	-26.3 °C	-29 °C
Flammability Risk	No	No	Low-Mid
Toxicity	Low	Low	Low

How Automotive Air Conditioning Works

An air conditioning system was first used in automobiles as early as the 1940s. Over the years, car air conditioning systems have gone through much change, although the basic concept of vehicle air conditioning remains untouched.

The basic components found in a vehicle air conditioner are the **compressor, condenser, evaporator, receiver drier and expansion valve**. All these components have a specific task. Hard tubing and flexible hoses connect all the components of the air conditioning system. Pressurized refrigerant in both states (vapour or liquid) passes around the whole system.

To understand the operation of the five major components of an automotive A/C system remember that the air-conditioning unit is divided into two sides:

- The high side of the system refers to the parts that are under high pressure and high temperature. These components are identified by smaller diameter tubing and very hot to the touch components.
- The low side of the system refers to low pressure components that are larger in diameter as far as the hoses and tubing and these components will be ice cold to the touch. This is very handy for diagnosis.

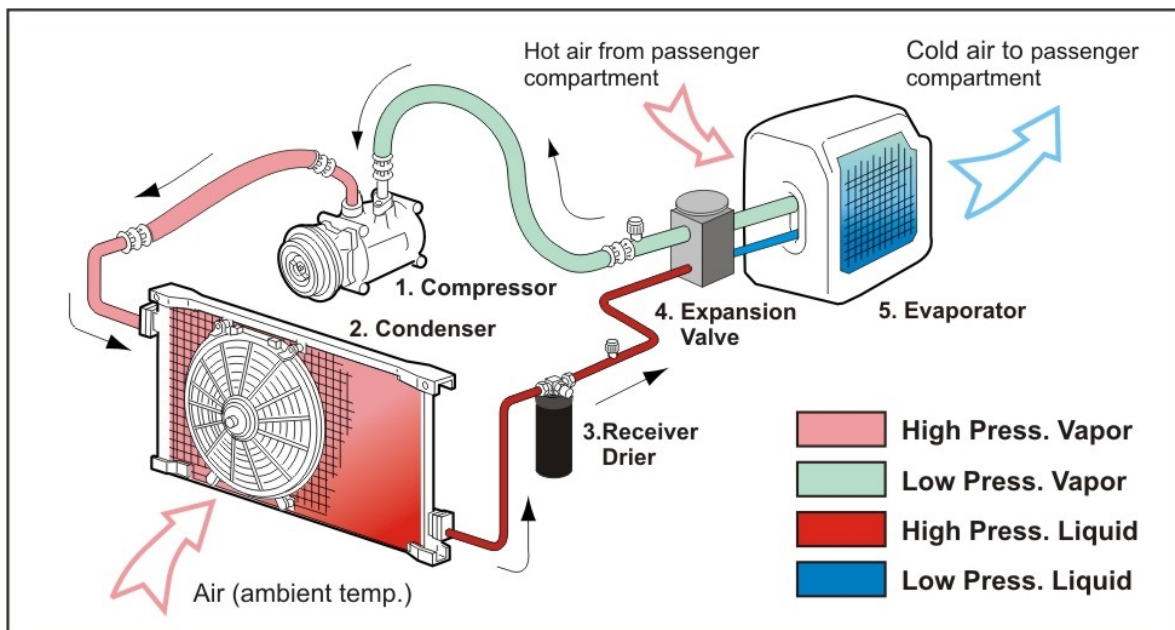

Compressor: The compressor is the work horse of the air conditioning system, powered by a drive belt connected to the crankshaft of the engine. When the air con system is turned on, the compressor pumps refrigerant vapor under high pressure to the condenser.

Condenser: The condenser is a device used to change the high-pressure refrigerant vapor to a liquid. It is mounted in front of the engine's radiator, and it looks very similar to a radiator. The vapor is condensed to a liquid because the heat is removed from the condenser by air flowing through the condenser on the outside.

Receiver-Drier: Now the liquid refrigerant moves to the receiver-dryer. This is a small reservoir vessel for the liquid refrigerant, and removes any moisture that may have leaked into the refrigerant.

Expansion Valve: The pressurized liquid refrigerant flows from the receiver-drier to the expansion valve. Expansion valve removes pressure from the liquid refrigerant.

Evaporator: The evaporator is another device that looks similar to a car radiator. It has tubes and fins and is usually mounted inside the passenger compartment. As the cold low-pressure refrigerant is passed into the evaporator, it vaporizes and absorbs heat from the air which comes from the passenger compartment. The blower fan inside the passenger compartment pushes air over the outside of the evaporator, so cold air is circulated inside the car.

Back to Compressor: The compressor then draws in the low-pressure refrigerant vapor to start another refrigeration cycle.

There are three types of automotive air conditioning systems: orifice tube, expansion valve or a combination of this two which is found in rear air conditioning systems.

Expansion Valve System

This system uses an expansion valve to meter the flow of refrigerant to the evaporator core. The expansion valve uses a temperature sensor at the evaporator core to determine the amount of refrigerant that it will allow to pass through its variable orifice.

An expansion valve system uses a receiver drier (3) which acts as a particle filter, refrigerant storage container and most importantly moisture absorber.

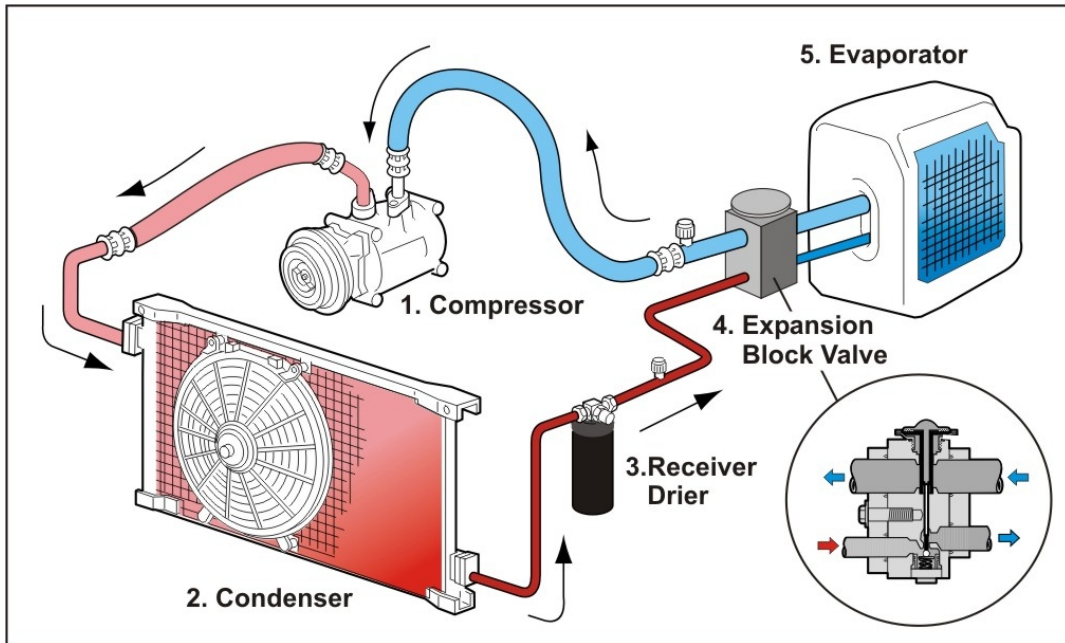

Orifice Tube System

This system uses an orifice tube to meter the flow of refrigerant to the evaporator core. The orifice tube has a brass sleeve with a fixed orifice and a screen to filter out any contamination.

An orifice tube system uses an accumulator (5) which function is to store refrigerant, filter particles, absorb moisture and separate vapor from liquid refrigerant.

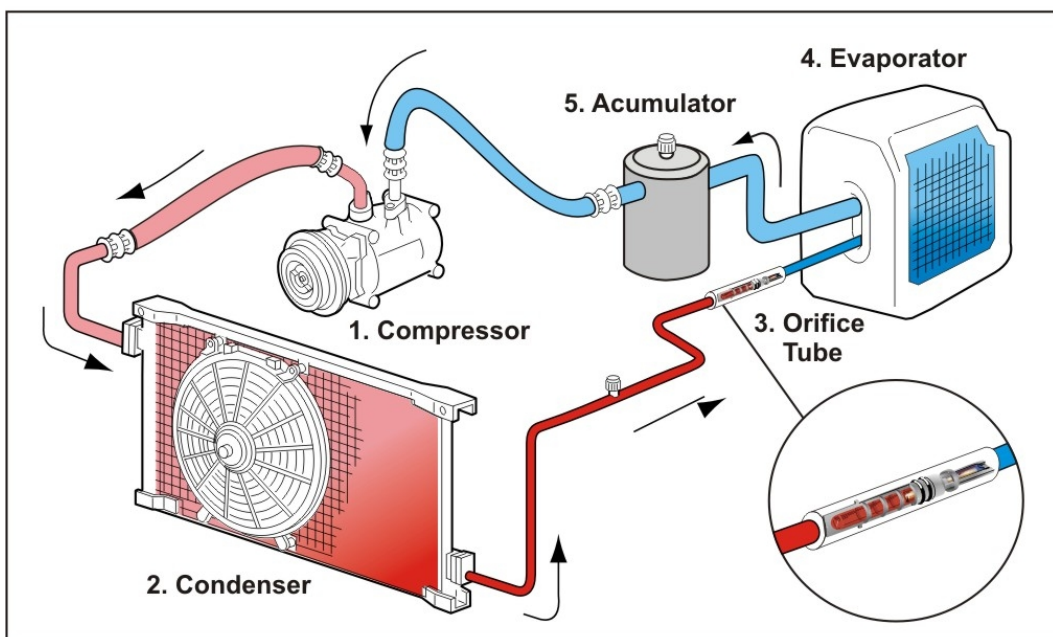

A/C Components Description

Compressor

In order for the A/C system to function, one side must be at high pressure, while the opposite side must be at a lower pressure. This pressure differential is the key to the cooling system. The compressor which is mounted between these two sides, compresses low pressure (low temperature) refrigerant gas, into high-pressure (high temperature) gas refrigerant. Inside the compressor pump, a rotor spins at high speed. The spinning rotor pulls refrigerant gas (from evaporator) into the inlet and pushes them out the other side (to the condenser).

At **mechanical compressors** the rotor inside the compressor is connected to the engine of the car using a belt. The belt connection allows the air conditioning to function when the engine is running but not when it is turned off.

New **electrical compressors** on new hybrid cars and electrical vehicles, provides air conditioning even when the engine shuts down to save fuel and emissions (not connected on engine).

There are few types of auto A/C compressors: piston-driven, scroll type, rotary vane type.

- The pistons are operated by a wobble (or swash) plate, which moves them backwards and forwards in the cylinders. As the front shaft turns the wobble plate angle changes, causing the pistons to move in and out, pulling refrigerant vapour in through the suction side, compressing it and discharging this high pressure vapour into the condenser.

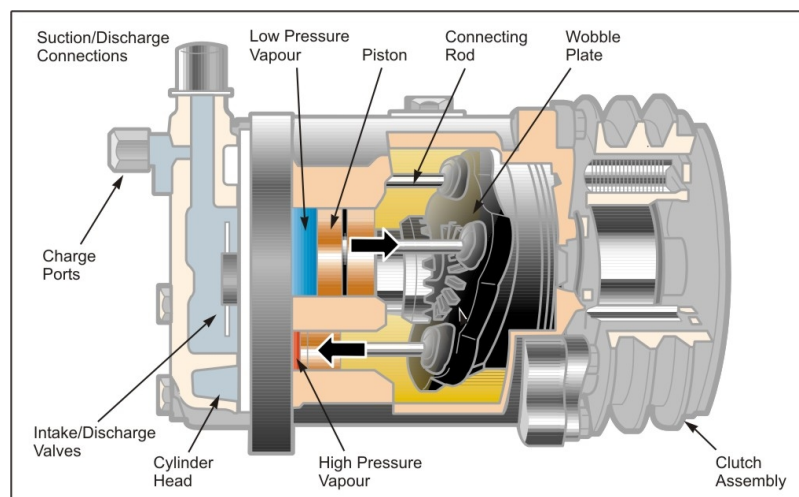

- The scroll type uses an orbiting spiral assembly to achieve pumping action. As the movable spiral oscillates within the fixed spiral, a number of pockets are formed between the spiral. As these pockets decrease in size the refrigerant is squeezed, the pressure increases and is discharged through a reed valve at the discharge port in the rear section of the compressor.

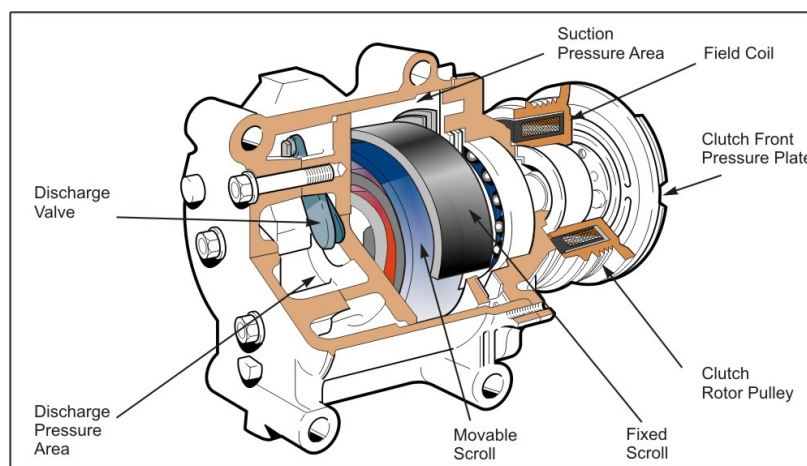

- Rotary vane compressors consist of a rotor with three or four vanes and a carefully shaped rotor housing. As the compressor shaft rotates, the vanes and housing form chambers. Refrigerant is drawn through the suction port into these chambers, which become smaller as the rotor turns. The discharge port is located at the point where the gas is fully compressed. The vanes are sealed against the rotor housing by centrifugal force and lubricating oil. The oil sump and oil pump are located on the discharge side, so that the high pressure forces oil through the oil pump and then onto the base of the vanes keeping them sealed against the rotor housing.

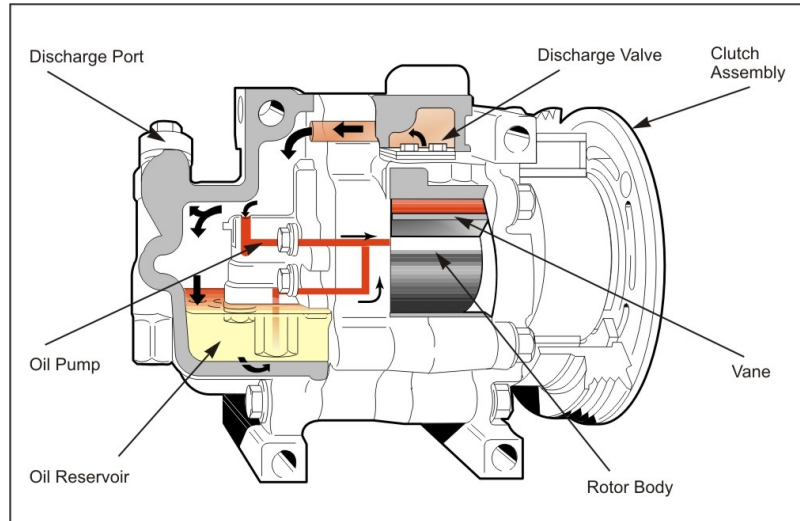

Compressor could be:

- **Fixed (F) displacement compressors.** These compressors compresses refrigerant in accordance with the engine rotation.
- **Variable (V) displacement compressors.** These compressors are able to controls refrigerant displacement from almost zero percent to 100 percent.

The traditional internally controlled **mechanical** valve has a precision pressure sensitive diaphragm that senses low side pressure. When the cabin temperature is warm, evaporator temperature increases, which increases low side pressure. This pushes on the diaphragm, opening a port that vents a little bit of housing pressure to the suction side. Reducing housing pressure increases piston stroke, which increases refrigerant flow volume through the system. As evaporator temperature decreases, so does low side pressure. The diaphragm "rebounds" to close the low-side vent port and at the same time open a port that admits high-side pressure into the housing. This reduces piston stroke and, therefore, refrigerant flow volume.

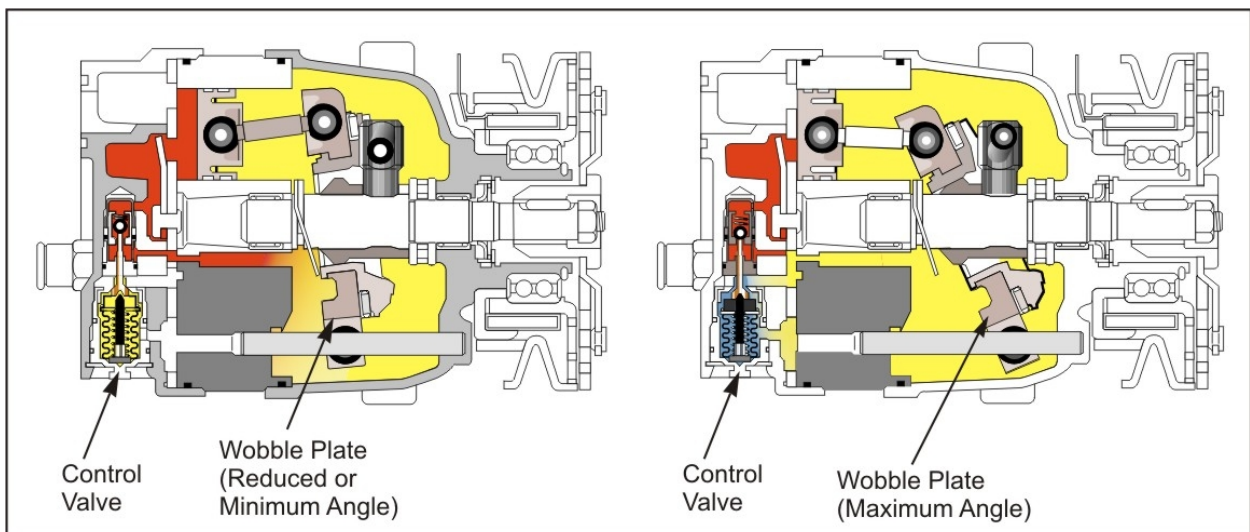

After 2002 the diaphragm valve was replaced with a solenoid valve and added temperature and pressure sensors in the refrigerant system. This allows a computer to control the valve and adjust compressor displacement to control evaporator temperature, rather than using evaporator temperature to control displacement.

Today almost all manufacturers offer external **electronically** controlled variable displacement compressors, and some applications have no clutch, meaning the compressor runs whenever the engine is running. Most vehicles already operate the compressor any time the windshield defogger is turned on, even in winter.

The electronic displacement control valve makes it easier to run the compressor continuously because displacement can be reduced closer to zero than with a mechanical valve. Continuous operation keeps seals lubricated, minimizes oil pooling and prevents other kinds of damage that result from long periods of inactivity.

Ultimately the electronically controlled variable displacement compressor puts less load on the engine, improving fuel economy. And of course, the driver will never feel the A/C clutch cycling or the idle speed surge that sometimes accompanies it.

The mechanical control valve is inexpensive and reliable, but it doesn't provide the same control as the electronic valve. Eventually most A/C systems will use an electronically controlled variable displacement compressor.

Electric compressors

The electric compressor used on new hybrid car and electrical vehicles provides comfortable air conditioning even during "idle" stops (when the engine shuts down to save fuel and emissions). This maintains cabin comfort while significantly reducing fuel consumption.

The electric compressor combines a scroll compressor and a DC brushless motor. The optimized scroll form and advanced motor control technology improves efficiency and reduces noise and vibration

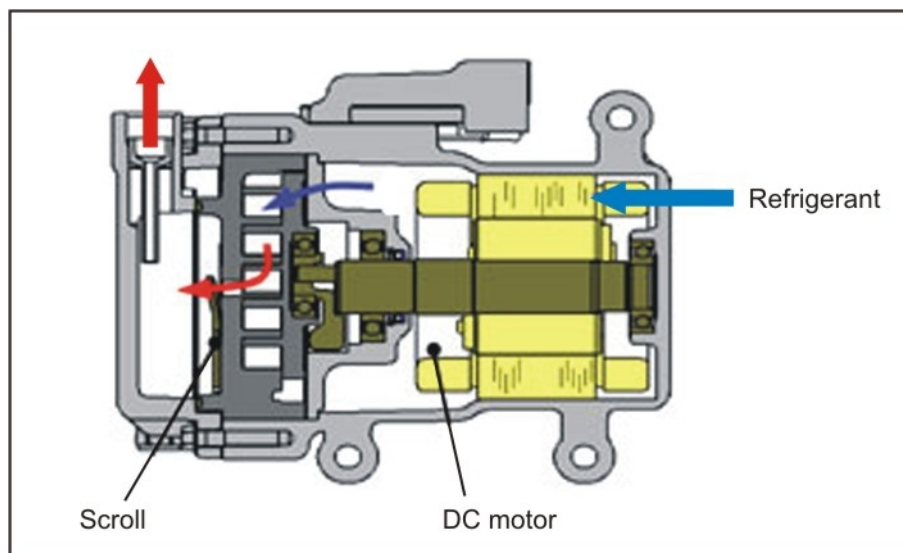

Compressor Clutch

The compressor clutch is an electro-mechanical assembly that transfers mechanical power from the engine to the compressor via a belt. The clutch engages the compressor using an electromagnet in response to various sensor input signals.

In older fixed-displacement compressors, the clutch would stop and start the compressor to control refrigerant flow.

For swash-plate and variable-displacement compressors, the clutch operates continuously.

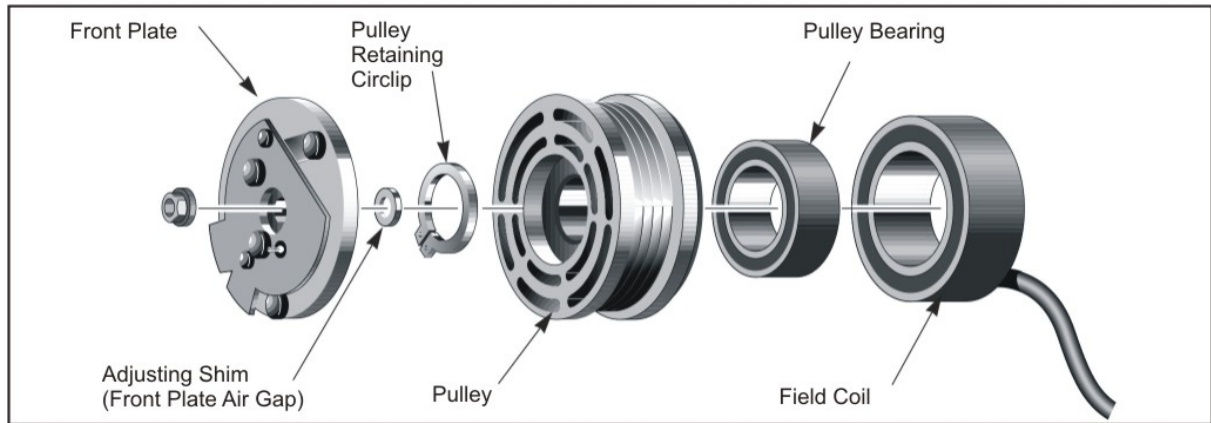

Compressor Mount & Drive

Consists of a bracket to mount the compressor to the engine, a belt idler pulley, compressor drive belt and possibly an extra drive pulley for the crankshaft.

Compressor bracket is manufactured of either plate, cast iron, steel or aluminium, this bracket should exhibit excellent noise absorption qualities especially if using a piston type compressor.

Idler Pulley used in conjunction with a belt adjusting mechanism, also used when a belt has a long distance between pulleys to absorb belt vibrations. Some vehicles do not have an extra pulley to accommodate an A/C drive belt, in these cases an extra pulley is bolted onto the existing crankshaft pulley.

Multiple Belt Drive

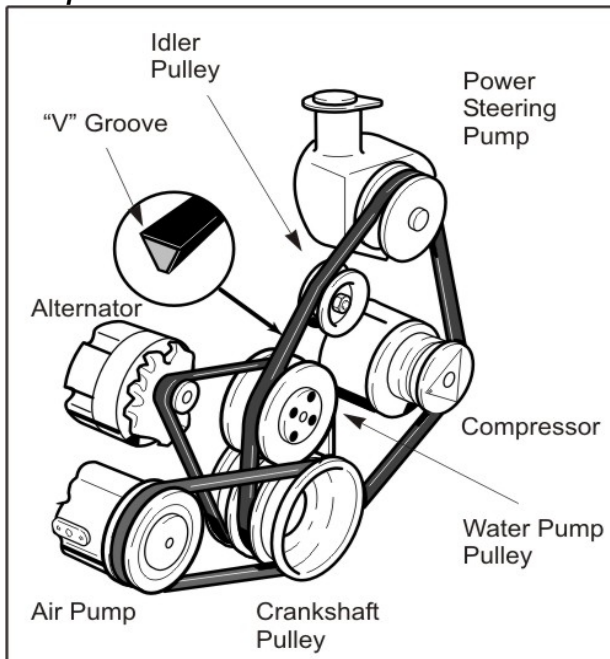

Serpentine Belt Drive

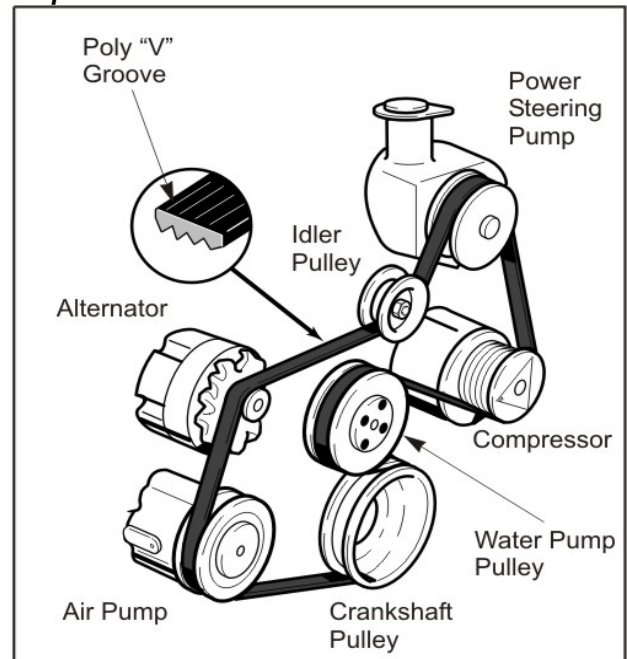

Condenser

The Condenser function is to act as a heat exchanger and allow heat to flow from the hot refrigerant to the cooler outside air.

An auto a/c condenser looks pretty much the same as the radiator of a vehicle's engine. It has fins and tubing that starts with an inlet and ends up with an outlet or discharge side. This air conditioning component is usually located right in front of the radiator where it receives open air flow from the grille and that of the existing engine fan. In some models, its location may be different but almost always near the grille where an open air flow is expected. In front-wheel drive vehicles though, electric cooling fans are used on their a/c condensers to ensure high performance.

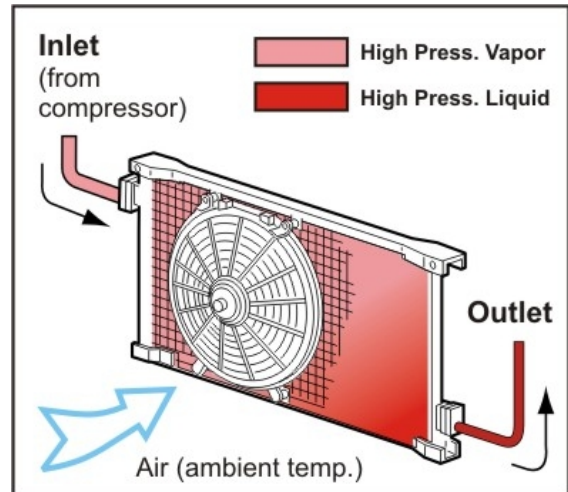

Refrigerant entering the condenser will be a high-pressure high temperature vapor. As the refrigerant vapor travels through the tubes of the condenser heat is given off to the cooler ambient air; the refrigerant vapor condenses and changes to a liquid state.

At this point a large amount of heat is given off and the refrigerant will now be a hot, high pressure liquid.

Design types

Serpentine - This type of condenser consists of one long tube which is coiled over and back on itself with cooling fins in between the tubes. Mainly used on old R12 air-con systems...

Parallel flow design - This design is very similar to a cross flow radiator. Instead of refrigerant travelling through one passage (like serpentine type), it can now travel across numerous passages. This will give larger surface area for the cooler ambient air to contact. Most manufacturers select the parallel flow design for this version. They are approximately 25% more efficient than the serpentine condensers.

Many newer vehicles are built with **MICRO-TUBE Parallel Flow condensers**. These condensers with minuscule passages have increased the A/C systems efficiency even more dramatically, however they are even more **impossible to flush** than their older bigger siblings and **must be replaced**.

Most of the "micro-tube" equipped vehicles, as well as many of the original parallel flow designs, also include the receiver drier. This can be a real advantage when servicing the AC system by benefit of automatically replacing the filtering device.

Serpentine Flow

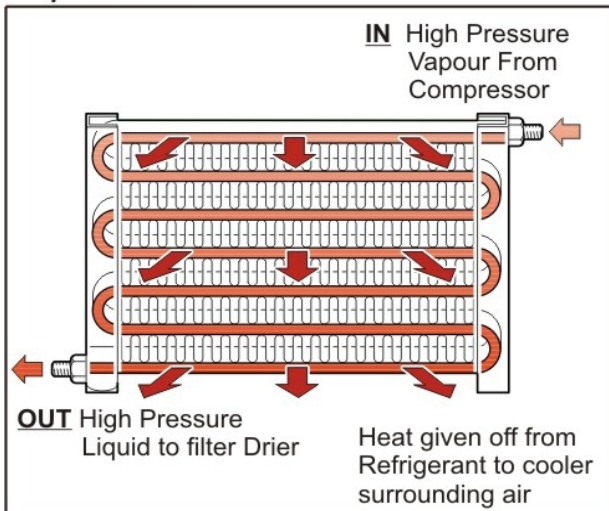

Parallel Flow

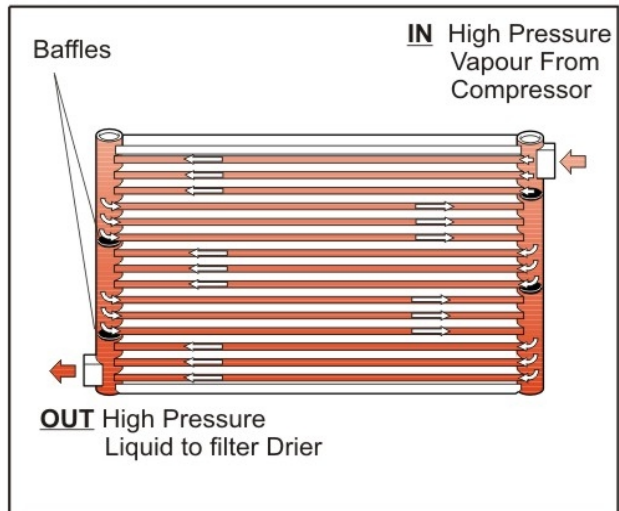

Foam seals

These seals are fitted in between the condenser and radiator to prevent the heated ambient air exiting above, below or to the sides of the space in between (normally 25mm) the radiator and condenser.

As ambient air is drawn through condenser by the condenser (or radiator) fan, its temperature increases. If gaps are present between the condenser and radiator this heated air can be circulated back through the condenser. This results in the increased condenser temperature and causes reduction in the performances of the A/C system.

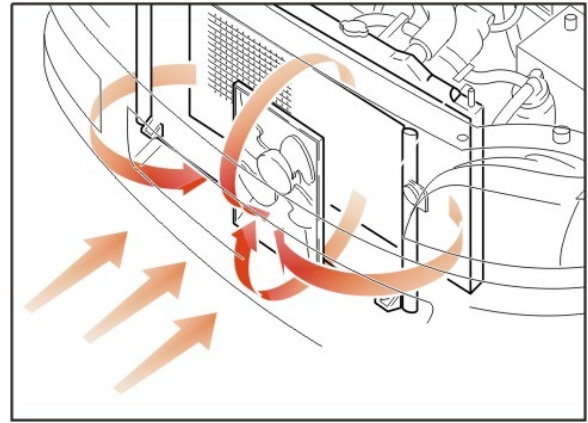

Condenser electric fan

The air conditioning condenser fan is a thermostatically or system controlled fan that pulls air through air conditioning condenser.

Most vehicles with air conditioning require an electric fan to assist air flow, either pushing or pulling the air through the condenser, depending on which side of the condenser the fan is placed.

The majority of vehicles require this additional condenser cooling due to the high operating pressures. Also most modern vehicles now have smaller grilles or bumper bar openings. This causes poor air flow conditions especially by the amount of air flow over the condenser.

The condenser fan is operated with A/C engaged in various ways:

- Medium pressure switch;
- Indirect connection to the compressor clutch
- Via the Electronic Control Module (ECM);
- Signal from the A/C switch activation.

Fan Types

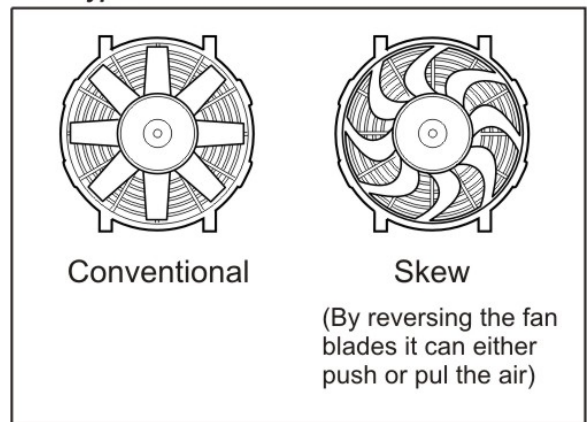

Basic Circuit

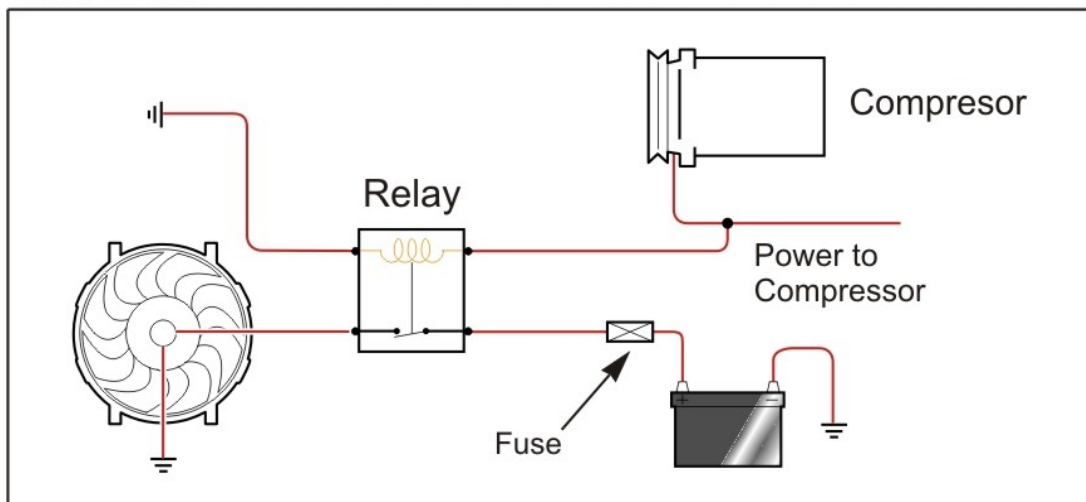

Evaporator

Refrigerant enters the evaporator coil as a cold low-pressure liquid. As this liquid passes through the evaporator coil, heat moves from the warm air blowing across the evaporator fins into cooler refrigerant. This air that has now been cooled is then ducted into the cabin via the blower motor.

When there is enough heat to cause a change of state, a large amount of the heat moves from the air to the refrigerant. This causes the refrigerant to change from a low-pressure cold liquid into a cold vapour.

As the warmer air blows across the evaporator fins, moisture contained in that air (humidity) will condense on the cooler evaporator fins. Condensed moisture then runs off through the drain tubes located at the underside of the evaporator case. This is why you see water dripping underneath a car while the air conditioner is on.

Air conditioning does not actually cool the interior of the vehicle. What it really does is remove heat and humidity from it.

In a typical passenger car the evaporator is usually located inside the passenger compartment, quite deeply buried in or under the instrument panel. Some vehicles, usually vans or SUVs, have two evaporators; one under the instrument panel and another one located in or toward the rear of the vehicle.

Evaporators are usually made of aluminum. They look like, and in fact are, similar to radiators, only thicker and smaller in overall size.

Design types

Serpentine evaporator

Same design as the serpentine condenser but approximately five times deeper.

Plate & Fin Laminated Evaporators

Similar operation to the parallel flow condenser were the refrigerant has a multi flow pass creating a large surface area.

Serpentine evaporator

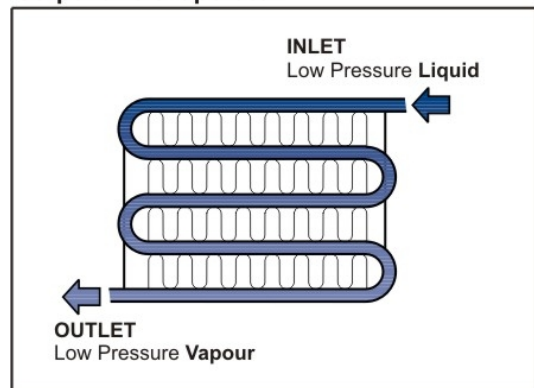
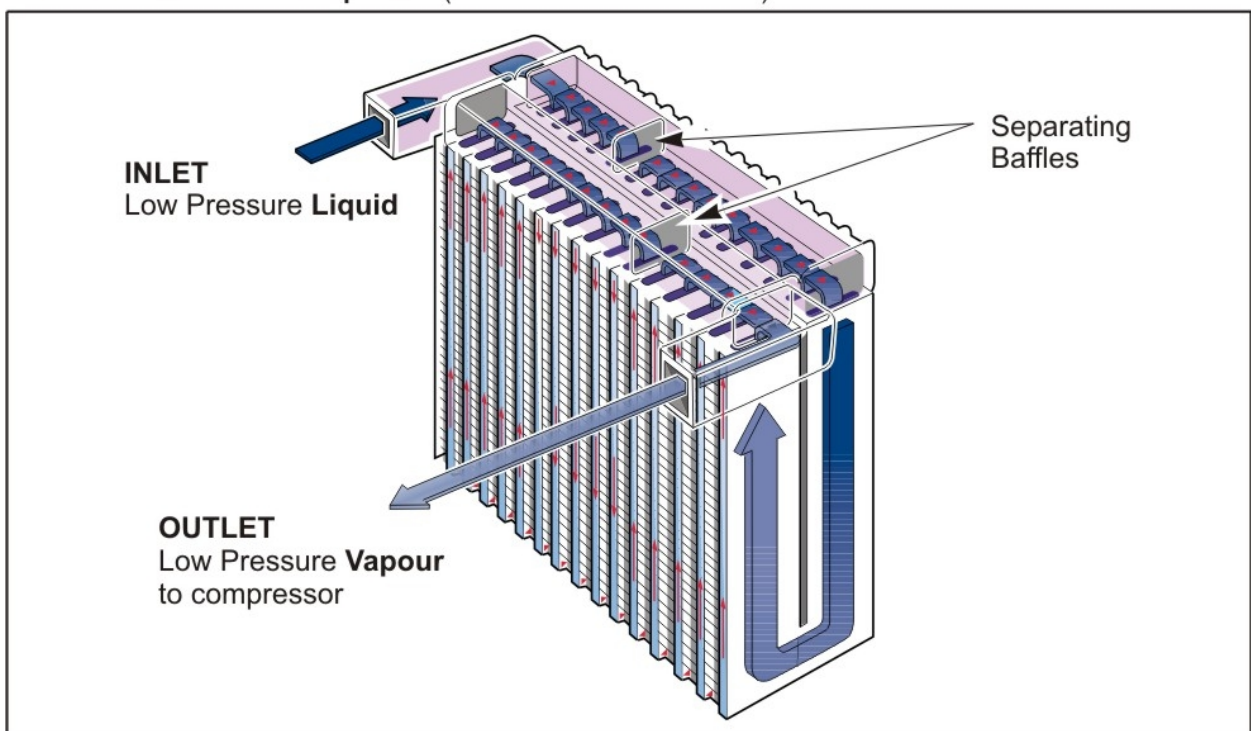

Plate & Fin Laminated Evaporator (Recommended for R134a)



Thermal Expansion Valves

The **expansion valve (TXV)** is placed in the system at the evaporator inlet and its job is to control the amount of refrigerant entering the evaporator. The expansion valve serves as a “dividing line” between the high and low pressure sections of the system.

Thermal Expansion Valve (TXV) has a temperature sensing device (sensing bulb) which measures temperature at the evaporator’s outlet and sends a signal to the movable rod inside the expansion valve. The warmer the evaporator is, the more refrigerant flow needed, and vice-versa.

When the evaporator outlet tube temperature increases, the refrigerant in the capillary tube expands, forcing the diaphragm downwards and thus pushing pin also downwards causing the ball to move away from the metering orifice, allowing more refrigerant to enter the evaporator inlet side.

As the evaporator outlet tube becomes cooler, the refrigerant in the capillary tube contracts which cause the diaphragm and pin to move upward allowing the ball to move towards the metering orifice, restricting the refrigerant flow. The outlet tube gets warmer and the process starts over.

Thermal Expansion Valves (TXV)

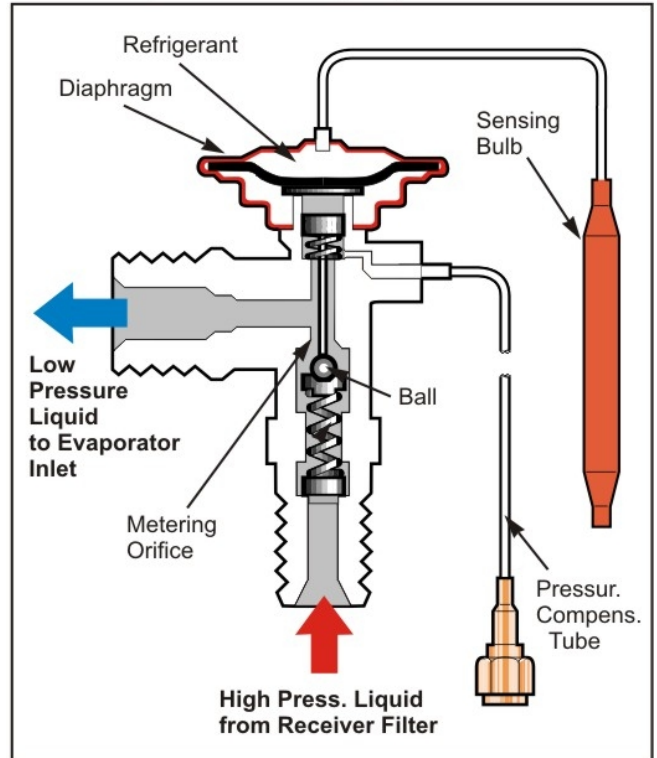

Thermal Expansion BLOCK Valve differs from the previously mentioned expansion valve in that it has four passages, although the basic operation is exactly the same. Operation of the block valve is still via refrigerant expansion/contraction within a diaphragm, but not sensed through separate tube (capillary tube). It is sensed by changes in the refrigerant temperature and pressure passing from the evaporator outlet through the block valve.

As the refrigerant from the outlet side of the evaporator passes over the sensing element, expansion or contraction of the refrigerant takes place causing the activating pin to move the ball away or closer to the metering orifice. This allows more or less refrigerant to enter the evaporator coil inlet.

Thermal Expansion Block Valve

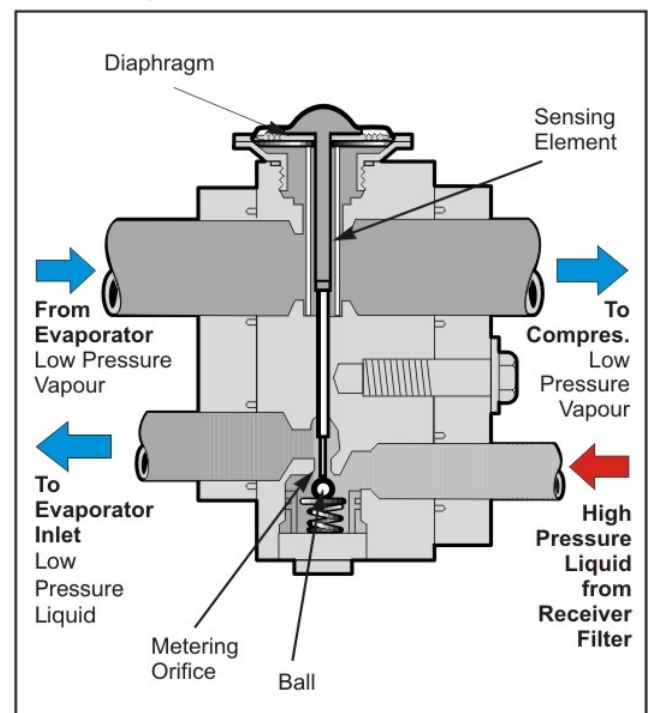

Orifice Tube

At the orifice tube system the refrigerant is forced to flow through a fine restriction (orifice). This causes a pressure drop (and temperature) in the refrigerant entering the evaporator.

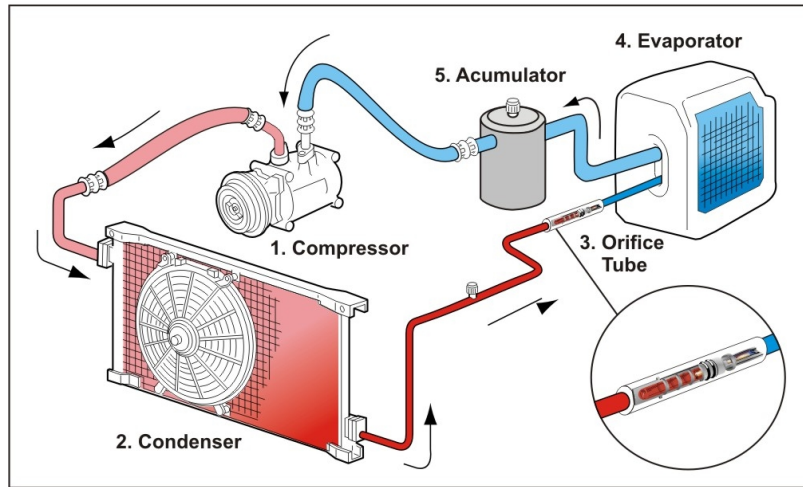

The rate of flow depends on the pressure difference across the restriction.

A fine gauze filter is located at the inlet and outlet sides of the orifice tube to filter any contaminants from passing onto the evaporator.

Orifice Tube

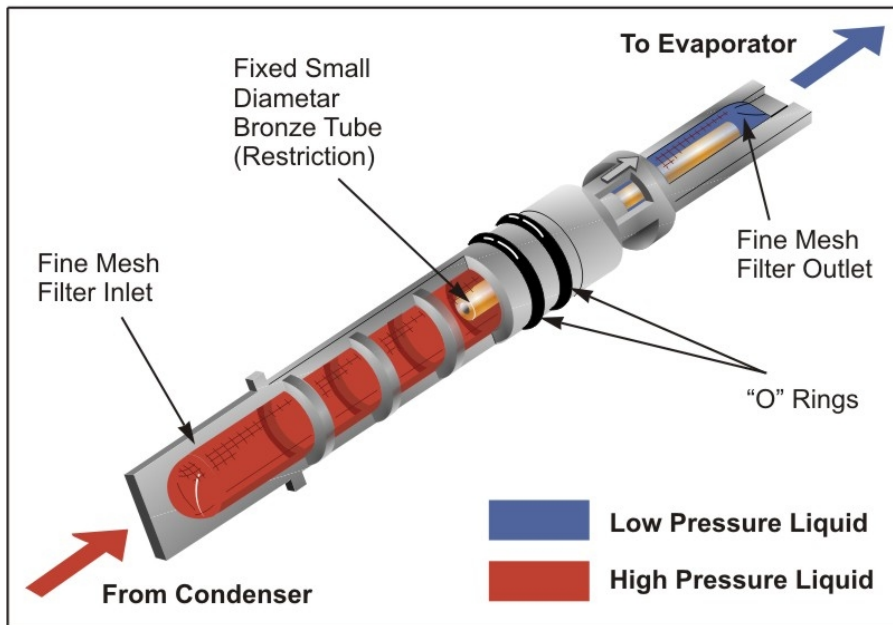

Orifice tubes have different size restrictions depending on the A/C system; these different sizes can be identified by the outer plastic tube colour.



Filter Drier Receiver

Receiver Driers are always used on A/C systems with Expansion Valve. They are positioned on the high-side of the refrigerant system, usually between the Expansion Valve Inlet and the Condenser Outlet. Many later-model vehicles have the receiver drier built into or on the condenser assembly.

The Filter Drier acts as a particle filter, refrigerant storage container and most importantly moisture absorber.

Moisture, temperature and refrigerant causes hydrofluoric and hydrochloric acid. The silica gel beads (desiccant) located in the Filter Drier absorb small quantities of moisture thus preventing acid establishment.

Today most refrigerant Filter Dryers have NO sight glass. This is because the PAG oil will foam giving a false impression of low gas charge. If the FDR does utilize a sight glass, ensure correct diagnosis when viewing.

Important: Ensure the connection indicated with the word "IN" is connected to the condenser outlet.

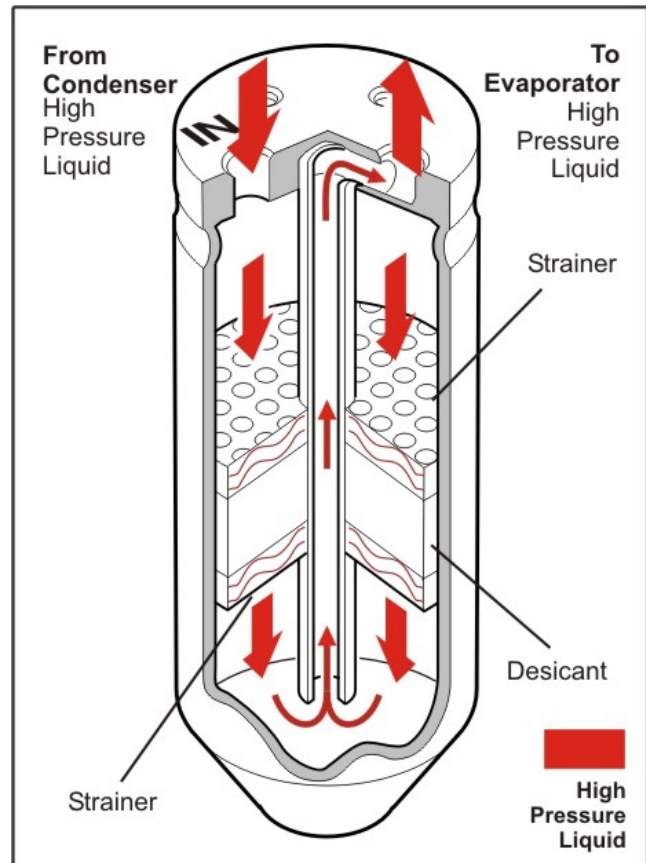

Accumulator

Accumulators are used only on orifice tube A/C systems, located on low side between the Evaporator outlet and Compressor inlet.

The function of the accumulator is to store refrigerant, filter particles, absorb moisture and separate vapour from liquid refrigerant. The normal process of the Orifice Tube system works when refrigerant leaves the evaporator coil as a mixture of vapour and liquid. This liquid enters the accumulator and falls to the bottom. The vapour rises to the top and continues onto compressor. The liquid refrigerant in the bottom of the accumulator gradually vaporizes off. This vapour rises and then pulls into the compressor.

Important: Accumulators and driers have a desiccant inside. When an A/C system is opened, the natural humidity in the air enters the A/C system, and the desiccant can become completely saturated. For this reason, it is important that the accumulator or receiver drier be replaced any time the A/C system is opened to the atmosphere.

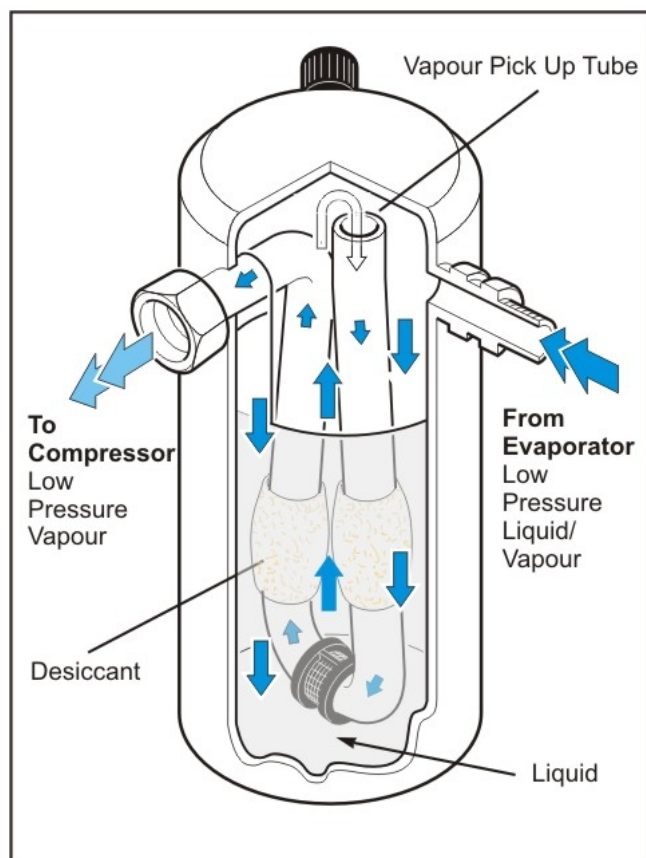

“O” Rings

An O-ring is a rubber gasket in the shape of a torus, with a round cross-section, designed to be seated in a groove and compressed during assembly between two or more parts, creating a seal at the interface.

Important: O-rings are available in various metric and inch standard sizes. Sizes are specified by the inside diameter (I.D.) and the cross section diameter (thickness).

The standard “O” Ring that has been in use in old **R12** air con systems is known as **NBR** (Nitrile Rubber). They are usually black, but could be any colour. The temperature range for NBR is -30 to 110 °C.

In most **R134a** air con systems today in use are **HNBR** (Hydrogenated NBR) “O” rings.

Its big advantage is its temperature range from -30 to 150°C, which is a big improvement on NBR. HNBR has excellent heat and oil resistance, improved fuel, ozone resistance and good abrasion resistance.

HNBR are frequently green, but they can be other colours also. Ford uses Green HNBR, Volvo started using a Blue HNBR and later changed it to Yellow HNBR. Currently, almost every automobile manufacturer uses more than one colour in their air conditioning systems.

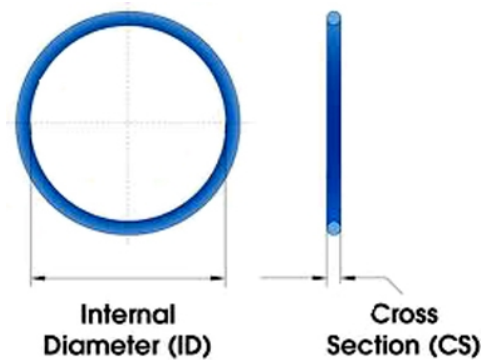

A/C Lines and Hoses

Air conditioning system lines and hoses are an integral part of the system. They direct refrigerant and oil between system components and they prevent leaks under conditions ranging from low temperature and pressure to high temperature and pressure. Hose diameter and type is determined by the application: rigid tubing (lines) between the evaporator and liquid refrigerant lines (low temperature and pressure), and flexible tubing (hoses) between the condenser and the compressor (high pressure and temperature).

Refrigerant hose is designed to effectively transfer the refrigerant (both liquid and gas) regardless whether they're hot or cold.

It comes in a flexible design so it can fit easily inside the air conditioning system. It's also equipped with metal crimping that prevents leaks from happening.

Because small molecular size and high operating pressures of refrigerant, the hoses incorporates a nylon inner lining. This is to reduce the normal refrigerant leakage that would naturally occur through the porosity of rubber hoses.

Usually hoses come in 4 different trade dimensions:

- Size 6 (3/4" O.D. – 5/16" I.D.) for 3/8" fitting
- Size 8 (29/32" O.D. – 13/32" I.D.) for 1/2" fitting
- Size 10 (1" O.D. – 1/2" I.D.) for 5/8" fitting
- Size 12 (1 3/32" O.D. – 5/8" I.D.) for 3/4" fitting

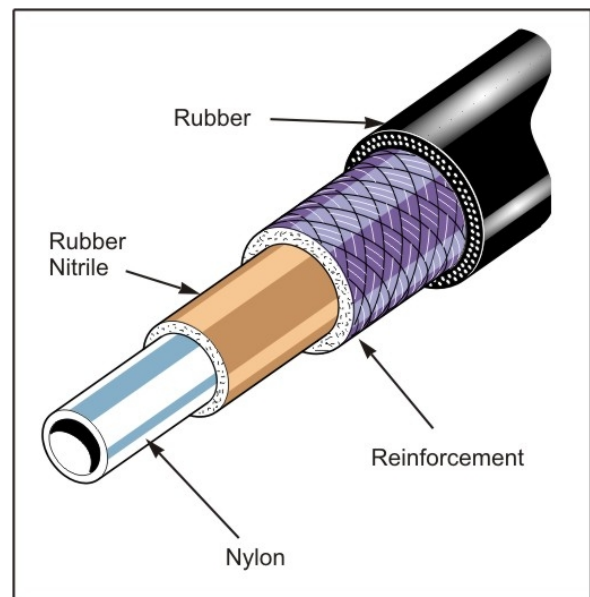

Charging Ports

The service ports provide access to the A/C system in order to check system pressures, add refrigerant or pull vacuum.

Each type of refrigerant, R-12, R134a or 1234yf has its own type of service port to prevent accidental cross-contamination.

Typically the A/C system will include two charge ports or service valves. One each for the high and low side of the system. The low side service valve or charge port will be located between the evaporator outlet and the compressor inlet and the high side charge port will be located anywhere between the compressor outlet to the expansion valve inlet. Different size ports identify the high and low sides of the A/C system. A plastic cap with rubber seal is used to close the charge port opening and avoid leaking.

Important: Most Schrader valves will leak slightly. Ensure that the plastic protection cap is fitted. Schrader valves designed for R134a must only be used in R134a systems. This is because of the seal material used.

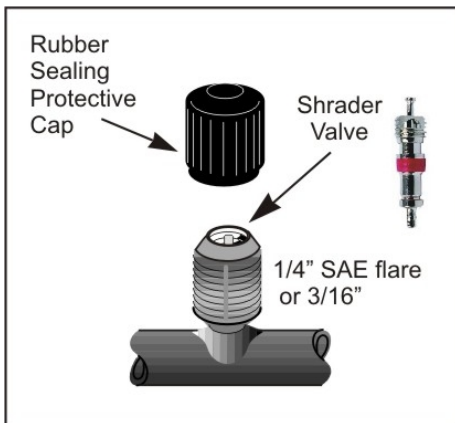

Older **R12** system (till 1994) service ports were threaded male flare fittings that the service hoses threaded onto.

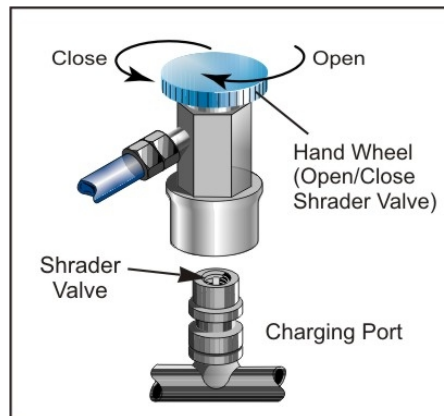

On **R134a (or 1234yf)** systems, the service ports are known as quick coupler ports. They require couplers that will snap onto the charge ports in order to access refrigerant pressures.

R134a Low Side Charging port

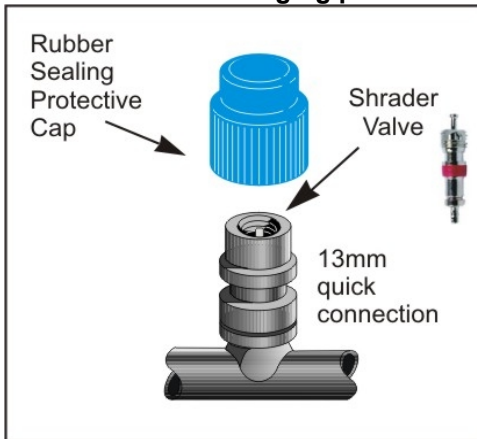

R134a High Side Charging port

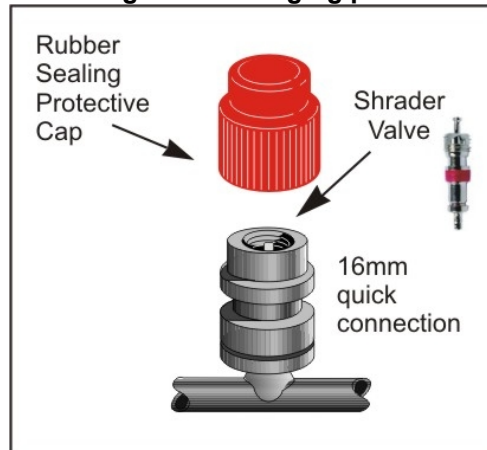

R134a - Quick Couplers



HF1234yf - Quick Couplers



HVAC Module and Intake Assembly

Most current HVAC systems consist of an HVAC module/unit assembly. The HVAC module assembly contains the heater core, the door system, and evaporator core.

The blower housing is a separate unit. The cooling unit in the HVAC assembly contains the evaporator core, the block type thermal expansion valve, and the door system. The intake unit contains the intake door, thermo resistor or fan control amplifier, and a blower.

A control system (controlled manually or electronically) directs air over the heater core to raise the temperature, over the evaporator to lower the temperature and humidity, and through the desired vents.

Climate Control Variations

There are two basic types of climate control:

- Manual temperature control (MTC) and
- Automatic temperature control (ATC).

Manual temperature control (MTC)

In vehicles with manual controls, the driver determines the airflow with a combination of settings, which directly control heating, air conditioning, vent position, and fresh air intake.

Control & Protection Devices

Pressure switches are connected in series with the compressor clutch. If an "under" or "over" system pressure occurs, the pressure switches will "open circuit", breaking the circuit to the compressor clutch.

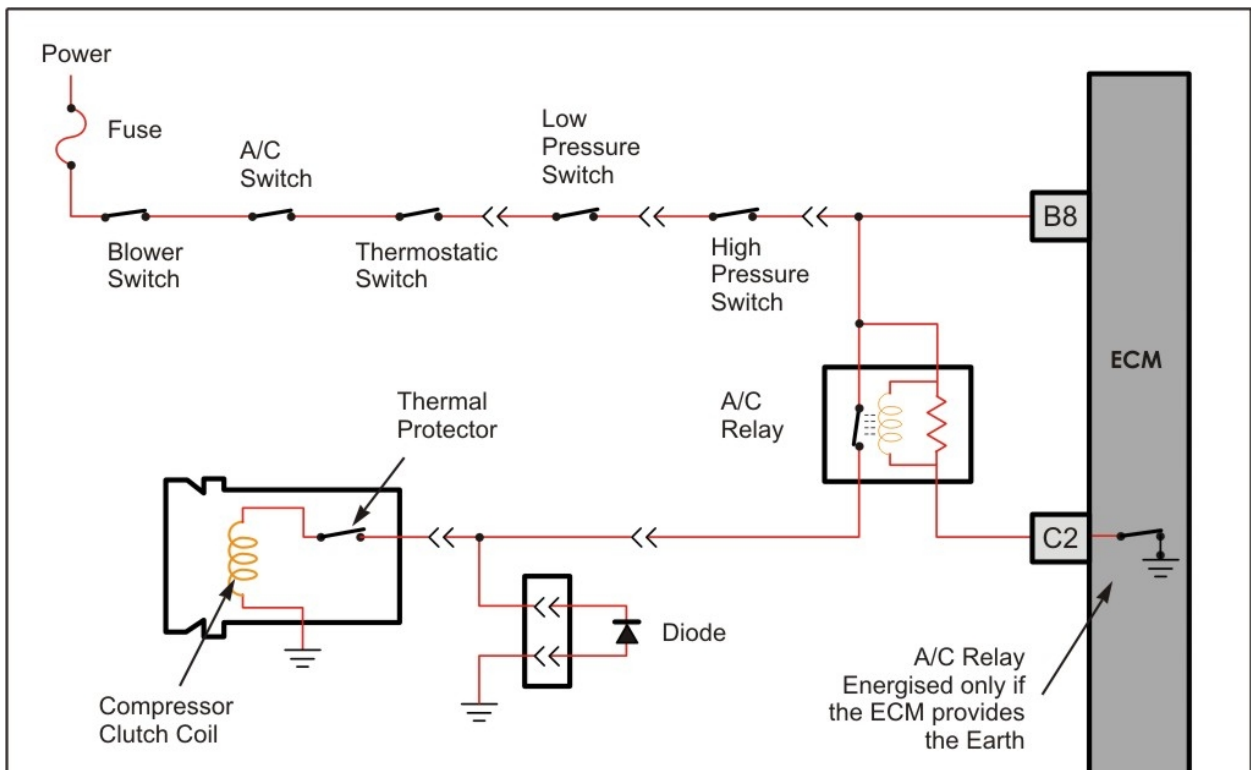

With electronic fuel injected vehicles the ELECTRONIC CONTROL MODULE (ECM) is usually interconnected into the A/C wiring circuit. When the A/C switch is engaged a request signal is sent to the ECM, if the A/C circuit is intact, i.e. the pressure switches are a closed circuit, the ECM activates a relay by creating an earth and power is supplied to the compressor clutch.

Also an RPM increase generally takes place to avoid engine stall whilst at idle.

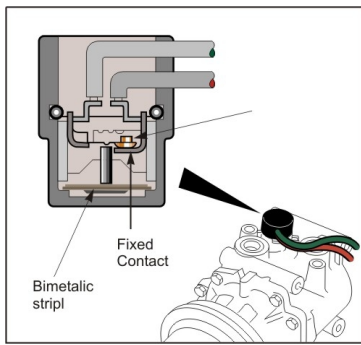

Compressor thermal protection switch

The thermal protection switch is normally located on the compressor housing. This protection switch is used to prevent compressor damage through internal friction. As the thermal protection switch is connected in series with the compressor clutch once the compressor case temperature lowers to a predetermined figure the compressor clutch is then re-energized.

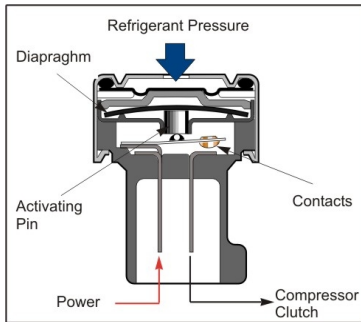

Refrigerant Pressure Switches

Low pressure - Used to interrupt the electrical circuit to the compressor clutch. If the refrigerant pressure is too low below 300kPa (3bar) or a problem exists in the A/C refrigerant system.

High pressure - The power supply is interrupted when the refrigerant pressure is too high, above 2400kPa (24bar) or a problem exists in the A/C refrigerant system.

Medium pressure - Used to engage the condenser fan at a pre-determined refrigerant pressure.

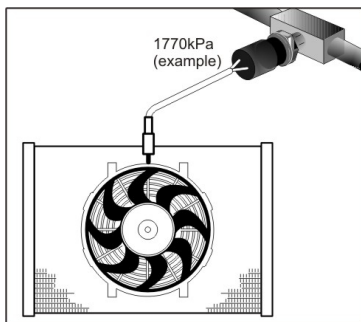

Example: Condenser fan high speed activation at 1770kPa (17.7Bar) refrigerant pressure.

These switches can be individual or a combination of the two or even three pressure ranges.

Binary switch - High/Low switch.

Trinary switch - High/Medium/Low switch

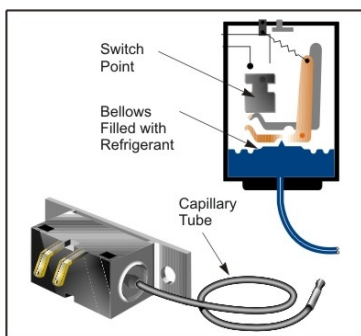

Thermostatic switch (Anti ice-up device) - When the temperature of the evaporator coil approaches freezing (0 °C), this temperature is sensed by the thermostat capillary tube which is in contact with the evaporator fins and interrupt the A/C electrical circuit turning the compressor OFF.

When the evaporator temperature rises again to a preset point (arr. 5 °C) the electrical circuit is re-established to the compressor clutch.

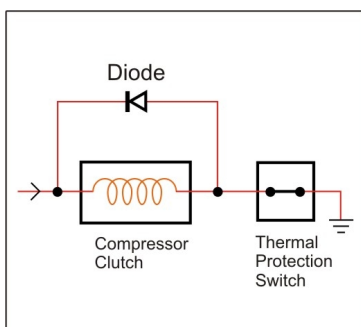

Clutch Diode

The clutch coil is an electromagnet with a strong magnetic field when current is applied. This magnet field is constant as long as the clutch is applied. When the power is removed the magnetic field collapses and creates high voltage spikes. These spikes are harmful to the ECM and must be prevented. A diode placed across the clutch coil provides a path to ground. This diode is usually taped inside the clutch coil connector.

Automatic Temperature Control (ATC)

Over the past decade, ATC has progressed from being a luxury item offered only on high-end models to an option available on nearly all models. The Automatic Temperature Control (ATC) system is designed to act much like a home thermostat for central heating. It keeps the interior of the vehicle at a set temperature without the customer monitoring the controls or changing the fan speed. In addition to keeping a constant temperature, the system tries to reach the set temperature in the most comfortable manner for the vehicle occupants.

The basic operation of the ATC system is the same for all vehicles. Briefly, the auto amplifier sends signals to the actuators to control the positions of the air distribution doors and the speed of the blowers, based on input from the temperature sensors.

The five major types of components of the ATC system are blowers, air distribution doors, temperature sensors, microprocessors, and actuators.

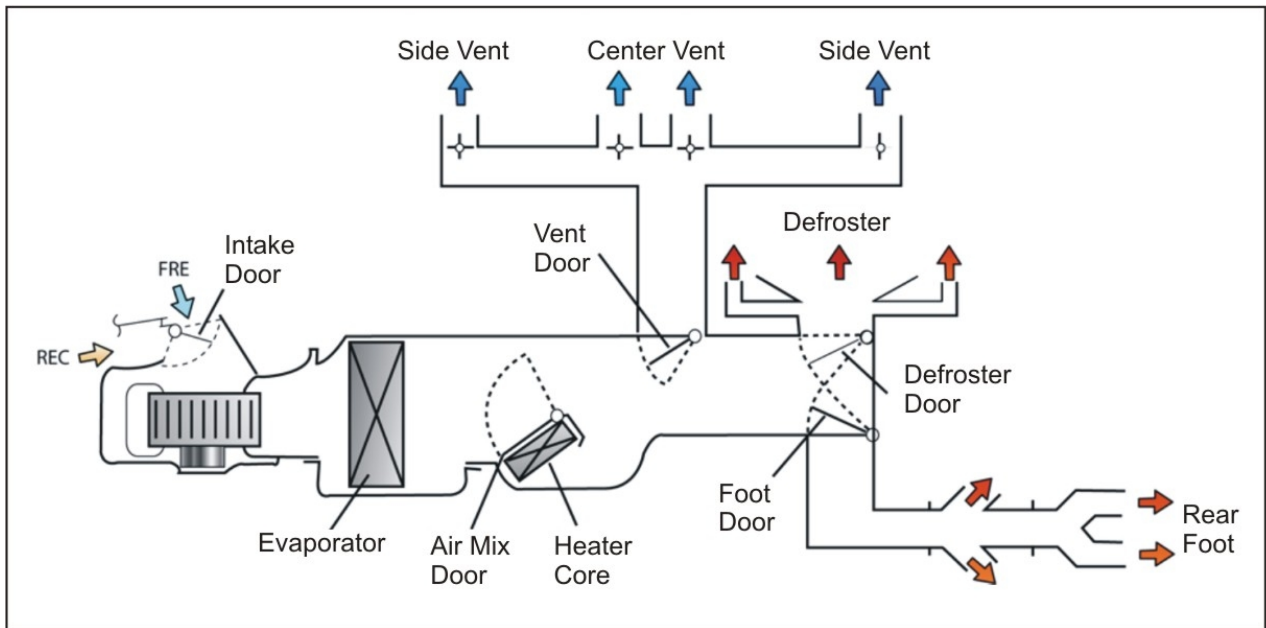

If the air mix door is stuck in the cold air position there will be no heating and possibly cold air blowing. If the air mix door is stuck in the hot air position, there would be no cooling and most likely hot or warm air blowing instead.

If the door is stuck midway, the air will always be warm rather than hot or cold as appropriate.

If the air mix is stuck on hot, the mode is stuck on defrost, and the intake is stuck on fresh air, check the unified meter and auto amplifier.

Automatic Temperature Control Components

An ATC system needs to monitor:

- Temperature outdoors (ambient sensor),
- Temperature inside the vehicle (in-vehicle sensor),
- Temperature of the heater core (thermal transmitter),
- The heat from sunlight shining on the vehicle (sun-load sensor).
- Temperature of the air at the evaporator (intake sensor) and
- Temperature of the vents (duct sensors).

The auto amplifier translates this input into commands to the motors for the air mix door, mode door, intake door, and the blower in the HVAC module. It also controls the operation of the compressor in fixed-displacement systems and the amount of coolant flowing through the heater core.

Unified meter and A/C Amplifier

Unified meter and A/C amplifier regulates air temperature, direction, and volume using inputs from various sensors and controlling the operation of components. This is similar to how the ECM monitors engine conditions and controls the fuel and exhaust systems.

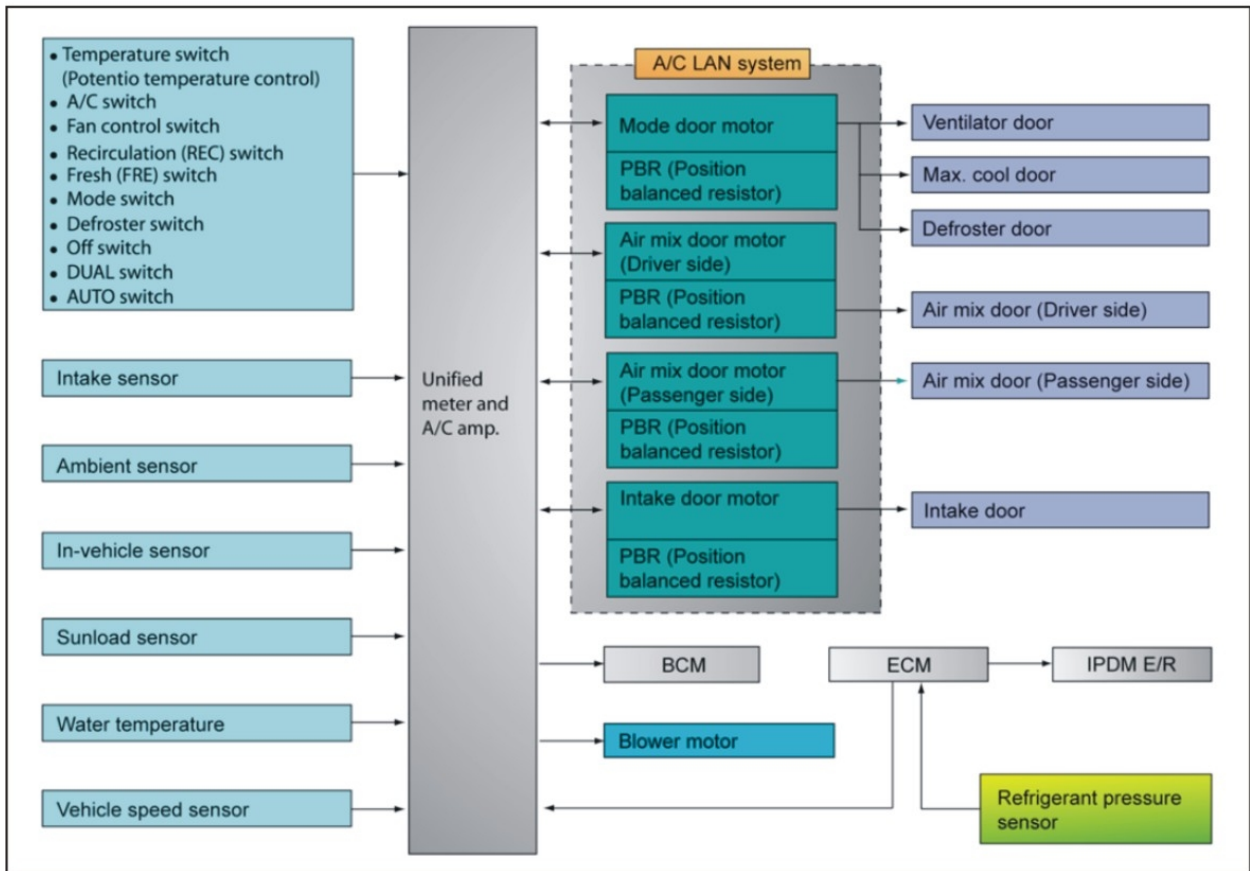

Since the unified meter and A/C amplifier is a microprocessor, either the component itself or the wires leading to it can be damaged or disconnected. If the unified meter and A/C amplifier fails, the ATC system will not function properly.

If the system appears to be stuck on defrost, fresh air, and heating, there is a problem with the unified meter and A/C amplifier and/or mode door motor. These are the default settings for safety reasons.

Fans and Blowers

Fans and blowers move fresh or recirculated air across the evaporator and heater cores to provide cooled or heated air for the climate control system.

Without blowers, the refrigerant inside the evaporator would absorb very little of the heat from the passenger compartment.

Similarly, the cold air in the passenger compartment would absorb very little of the heat from the hot coolant inside the heater core.

In a vehicle with ATC, the unified meter and auto amplifier sends signals to the fan speed control to determine the speed of the blower, according to the operating conditions.

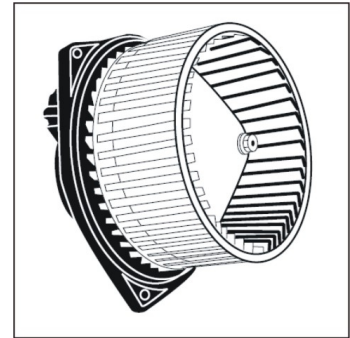

Fans and blowers rarely fail. However, there are still a few potential problems:

- Foreign objects may obstruct or damage the blades
- Wiring or controls may fail
- Bearings may wear and fail

A distinctive buzzing or rattling noise from the dashboard area when the fan is running usually indicates leaves, paper, or other debris have fallen inside the blower. Other noises may indicate something more substantial damaged the blades, or the bearings are worn.

If the fan will not operate at all, it is most likely a control or wiring problem. Since fan and blower operation depends on several different controls, failure of any of those components or their wiring will prevent the fan or blower from operating. The fan may also have been disconnected from its power supply or ground.

Fan Speed Control. Fan speed is based on the difference between the set temperature selected by the customer and the actual temperature of the vehicle interior. If there is a big difference between set temperature and the actual interior temperature, the system switches to a high fan speed. As the interior temperature approaches set temperature the fan speed decreases.

Fan speed also varies to compensate for sun-load. On some vehicles, fan speed also varies according to the ambient (outside) temperature. Fan speed can also be manually controlled.

In-vehicle Sensor

The in-vehicle sensor sends passenger compartment temperature information to the auto amplifier. The sensor is located on the instrument panel near the driver side. The sensor converts variations of in vehicle temperature into a resistance value which is input into the unified meter and A/C amplifier.

Compressor Clutch Control

In vehicles without variable-displacement compressors, the compressor clutch is ON any time the ATC system is in the automatic or defrost modes unless the ambient temperature is too low (below 5°C).

Since the compressor clutch control is an electrical component, either the part itself or the wires leading to it can be damaged or disconnected. If the compressor clutch control fails, the compressor will not cycle ON. This will also occur if either the auto amplifier or the ATC receives an improper signal.

If the compressor does not cycle ON the compressor clutch control is a possible cause.

Ambient Sensor

The ambient sensor sends outside air temperature information to the unified meter and A/C amplifier. It is located just inside the vehicle's grill, in front of the condenser.

Since the ambient sensor is an electrical component, either the component itself or the wires leading to it can be damaged or disconnected. If the ambient sensor fails, the ATC system will be unable to determine the outside temperature and the air conditioner may not cycle on. If the circuit is open, this signal will be interpreted as a very low temperature. The unified meter and A/C amplifier will not send a signal to turn on the compressor.

If the air conditioner will not blow cold even though touch and feel diagnosis shows the refrigerant loop is functioning properly, the ambient sensor is a possible cause.

Sun-load Sensor

The Sun-load sensor measures the amount of sunlight entering the vehicle and sends this information to the unified meter and A/C auto amplifier. Sensor converts the Sun-load into a current value which is then input into the unified meter and A/C auto amplifier. The sensor is located on the dashboard near the windshield.

Since the Sun-load sensor is an electrical component, either the part itself or the wires leading to it can be damaged or disconnected. If the Sun-load sensor fails, the ATC system will be unable to determine whether or not sunlight is warming the passenger compartment, and will not cool the car sufficiently on hot, sunny days.

Intake Sensor

It is located behind the dashboard near the evaporator. The sensor determines evaporator and intake air temperature.

Since the intake sensor is an electrical component, either the part itself or the wires leading to it can be damaged or disconnected. If the intake sensor fails, the ATC system will be unable to determine the evaporator is working and the air conditioner will not cycle on or off as expected.

When the intake sensor fails, it appears to be an open circuit. This is interpreted by the system as a signal that the evaporator or intake air temperature is too cold, and the compressor is turned off.

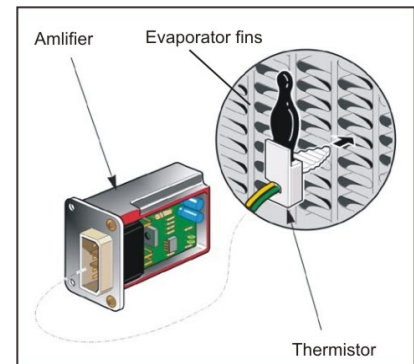

Refrigerant Pressure Sensor

The refrigerant pressure sensor attaches to the condenser. The sensor protects against excessively high or low refrigerant pressures. If the pressure rises above or below specification, the refrigerant pressure sensor sends a voltage signal to the ECM indicating high or low pressure in the refrigerant system.

The sensor could stay at a specific voltage or go above or below the specification causing the AC compressor magnet clutch to be inoperative.

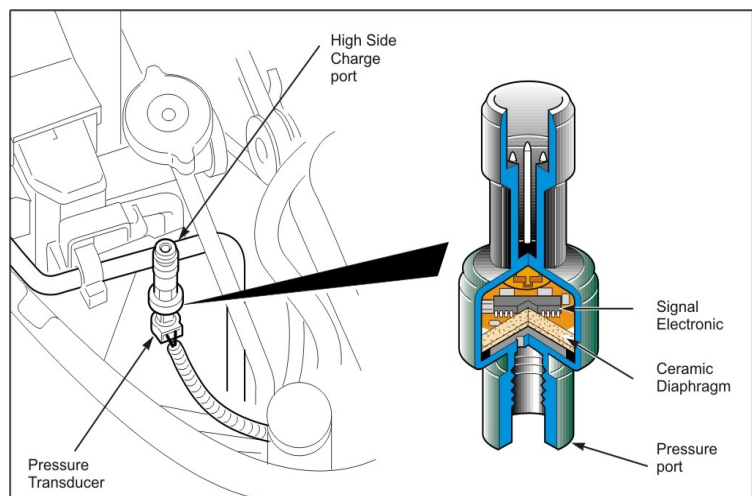

Air Mix Door and Motor

The air mix door position is controlled by the unified meter and auto amplifier and ATC, based on input from the various input sensors. The position of the air mix door directs cold air, hot air or a mixture of cold and hot air into the passenger compartment to arrive at the set temperature.

The control rod to the air mix door can get dislodged or misadjusted, or the air mix door motor can fail. Also, the switch on the control panel or the connection to the auto amplifier can be damaged.

If the air mix door is stuck in the cold air position there will be no heating and possibly cold air blowing. If the air mix door is stuck in the hot air position, there would be no cooling and most likely hot or warm air blowing instead. If the door is stuck midway, the air will always be warm rather than hot or cold as appropriate.

If the air mix is stuck on hot, the mode is stuck on defrost, and the intake is stuck on fresh air, check the unified meter and auto amplifier.

A/C Service Equipment

All automotive A/C systems eventually require service. A typical A/C system needs recharging every three or four years as contamination in the system (water, incorrect oil, dirt, metal fragments, acids) can cause a wide variety of problems.

Refrigerant Recovery & Recycling Equipment

The purpose of the Recovery & Recycling is to recover refrigerant from the air conditioning system, which will condense, purify and store the liquid refrigerant in the unit cylinder ready for re-use.

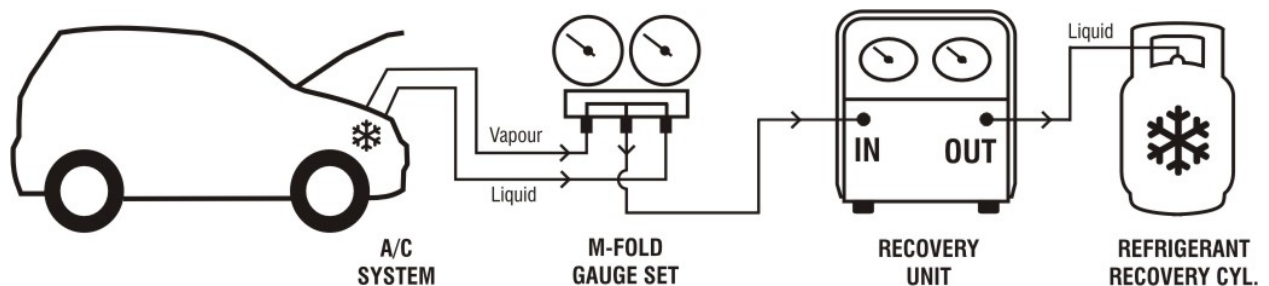

All refrigerant must be recovered from the vehicle's A/C system prior to opening the system for repairs. The refrigerant then **must be recycled** to meet certain purity standards.

The fact that R134a adds to the Global Warming Potential (also from a cost point), it is still mandatory that it be recovered and recycled.

What's Important:

- Use only approved Recovery and Recycling equipment (recovery units, cylinders and hoses).
- Change device filters when suggested by equipment manufacturer.
- A scale must be used to avoid overfilling the storage tank. Tank is full at 80% volume.
- Ensure oil collected during recovery is replaced into the A/C system with new oil.

Ariazone 601HD – Refrigerant Recovery & Recycling Unit

The Ariazone 601HD is lightweight **all in one** refrigerant **recovery & recycling** system for the on site mobile technician or small workshop operator. This system has been designed to be very user friendly and efficient for every user. Simply connect the Ariazone to the air conditioning system switch on and walk away. The 601 will take care to the rest.



The unit is designed to be:

- User friendly (fully automatically operation)
- Safe (built in high pressure and liquid control protection)
- Durable (compressor with thermal protection)
- Universal (recovers vapour or liquid)
- Simple maintenance (easy accessible filter)

Specifications:

- Recovery Rate: 0.2kg/min (liquid state)
- Dimensions: 230mm x 380mm x 220mm; 18kg
- LP&HP gauges - AI-D 68-L mm kl.1.0
- High pressure protection 24bar
- Large filter dryer - AI FD162-1/4"
- Oil separator OS-100/76
- Easy start compressor against high block-pressure
- Chassis - Sturdy all steel construction powder coated.
- Supply voltage - 230V/50(60)Hz

Evacuation Equipment

A single drop of water may look harmless, but to a refrigerant system, it is the number one enemy of the service technicians because moisture enters a system easily and is hard to remove.

- Moisture forms ice crystals at the expansion valve which retard or stop the flow of the refrigerant, causing loss of cooling. As the expansion valve warms, due to lack of refrigerant, the ice melts and passes through the expansion valve. The refrigerant will then start again until the moisture returns to the expansion valve and once more builds ice crystals. The result is intermittent cooling.
- Moisture mixed with refrigerant creates corrosion trouble.
- Some refrigerant oil attracts moisture and will absorb it rapidly if left open to the atmosphere. Water-formed acid mixes with refrigerant oil, forming a closely bonded mixture of fine globules. The effect is called "sludging" and greatly reduces the oil's lubrication ability.

The most effective way to eliminate moisture from a system is with a good vacuum pump. The purpose of a vacuum pump is to remove moisture and air from an A/C system. Vacuum pump actually does not "suck out" the liquid moisture, but causes it to boil in to a vapour state which can be harmlessly removed from the system and exhausted through the vacuum pump exhaust.

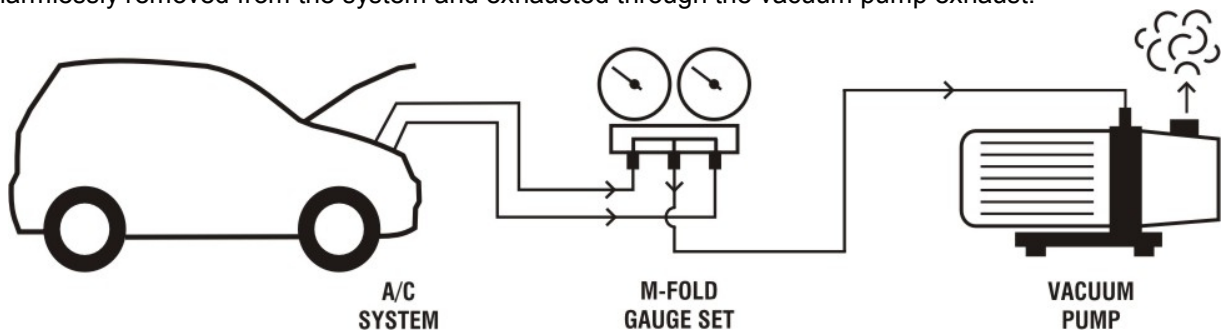

Modern systems are built tighter and charges are more critical. That means these systems have a greater sensitivity to moisture and other contaminants, making thorough evacuation more important than ever before.

What's Important:

- Use 2 (dual) stages vacuum pump only.
- Use 3/8" connection hoses between the pump and m-fold.
- Minimum capacity 2.5cfm (70lit/min)
- Change the vacuum pump oil every 30-40 working hours. Use only high quality vacuum pump oil.
- The lower number in microns, the better the pump.
- Dehumidification starts properly at levels of 1,000 microns (or less). The use of an electronic vacuum gauge clearly indicates whether the level is reached and whether it is maintained as well.

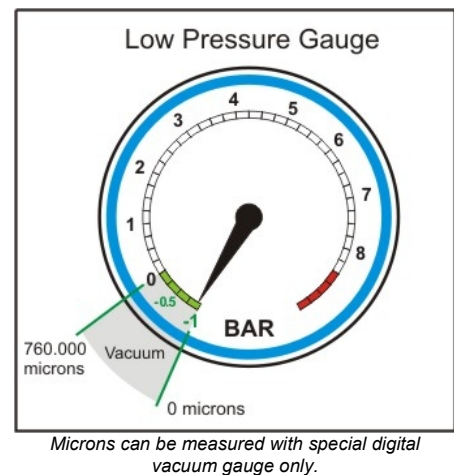

Ariazone Vacuum Pump (with solenoid valve and vacuum gauge)

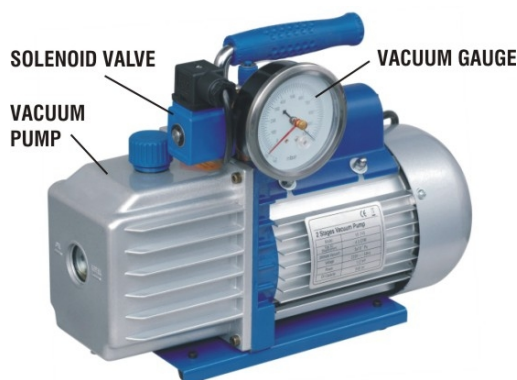

Dual stage vacuum pump with solenoid valve and vacuum gauge, easy to carry due low weight. Very low noise levels make it a pleasure to operate.

- Two stages
- Vacuum gauge D80mm with adjustable pointer
- Large solenoid valve
- 3x10Pa (25 microns) ultimate Vacuum
- 3.5 CFM (100 l/min)
- Finned alum. housing for lower operating temperature
- Motor 190 W (1/4 HP), Capacitor start,
- Intake fitting 3/8" & 1/4" SAE flare
- Oil capacity 300 ml
- Power supply - 230V / 50-60Hz

Charging Equipment

The purpose of the refrigerant charge equipment is to batch a user-defined weight amount of refrigerant into the air-conditioning system. Charging correct amount of refrigerant will ensure the proper capacity and efficiency from air-conditioning system.

Important: Before start refrigerant charge A/C system MUST be properly evacuated and leak tested.

Charging by weight by using the digital refrigerant scales is the most accurate and fastest methods of charging a system that has a known refrigerant charge (manufacturer recommendation).

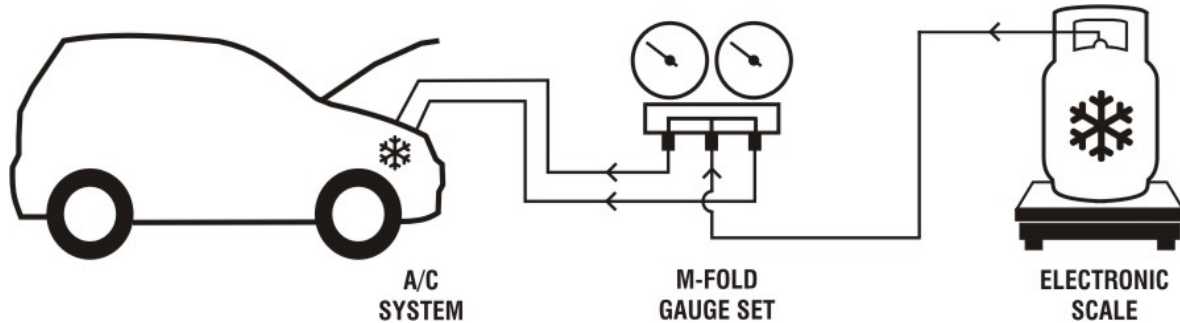

What's Important:

- Use only precise charging stations equipped with solenoid valve for automatic charge shut-off.
- 50kg minimum weight

Electronic scale with automatic charge shut-off

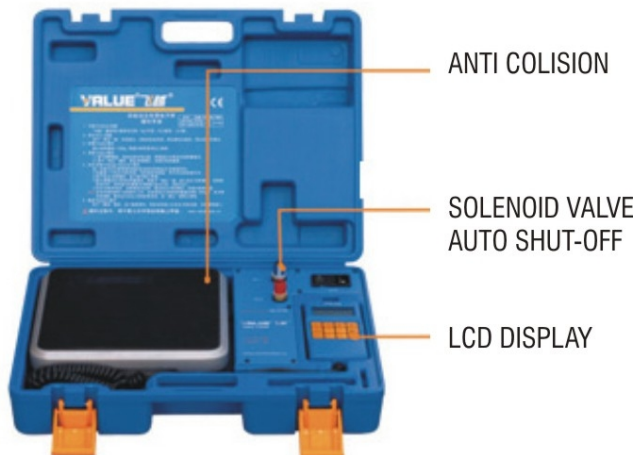

Specifications:

Weighing range: 50kg(110lb)
Resolution: 2g/0.01lb/0.1oz
Accuracy: 0.05%
Display: LCD (7 segment)
Power: 220V or 110V AC P
Platform Size: 237×237mm
Weight: 5kg

All in One Unit – Automatic A/C Service Station

Rather than have a machine that only recovers refrigerant and then a vacuum pump and charging scale to complete the task of servicing an A/C system, there are all in one machines that incorporate all the necessary functions required to start and complete a full air conditioning system diagnosis and service, which can operate manual (step by step) or in fully automatic mode.

Basic functions of all in one unit include:

- A/C system test by reading the gauges
- Refrigerant Recovery & Recycling
- Recovered Oil Drain
- Evacuation of the system
- Oil & UV Dye Injection
- Refrigerant Charge by weight

Above basic, Full Automatic machines features:

- Automatic Oil Reintegration
- Vehicle Database
- Integrated Thermal Printer
- Refrigerant Management
- USB connection to PC

Last generation advanced machines also features:

- Flushing the A/C system with refrigerant
- Oil injection for electric compressors
- Diagnostic of a/c system failures
- Refrigerant analyzer
- Wireless temperature probes
- Wireless Bluetooth connection with PC
- Touch Screen

What's Important:

- The unit must be able to recover 95% of the refrigerant contained in the air con within 30 minutes.
- Refrigerant must be charged with an accuracy of +/- 15 g.
- Refrigerant recovery must be made and displayed with an accuracy of +/- 30 g.
- Dual stage vacuum pump minimum 2.5cfm (70lit/min) or larger.
- High efficiency filtration and oil separation system
- Regular maintenance of the unit (calibration, filter and vacuum pump oil change).



1988

Ariazone 2002 was the first all in one machine, which was capable of carrying out all the necessary functions, for servicing automotive A/C systems, such as recovery, recycling, evacuation, oil injection and charging.

1993

Ariazone 4001 was the first electronic fully automatic refrigerant processor worldwide, incorporating digital display, remote control and electronic oil injection.



Ariazone 5001 FAHD

Full Automatic A/C Service station

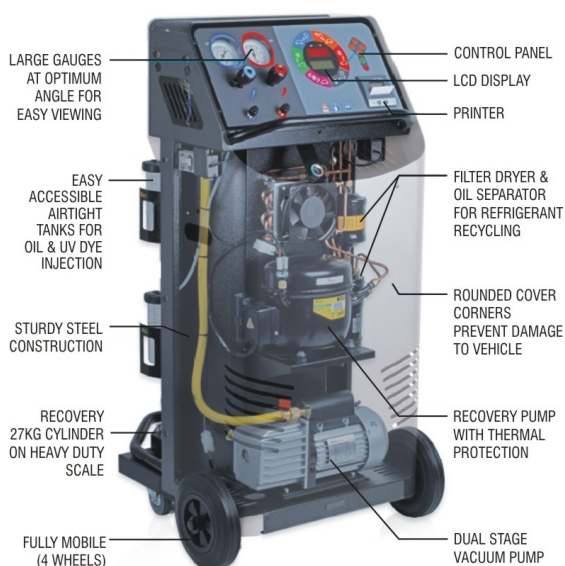

Ariazone 6001

Advanced Refrigerant Processor



A/C Flushing Equipment

When a compressor fails, a lot of metallic debris is often thrown into the system. Most of this debris collects in the condenser where it can cause blockages that reduce cooling performance. Debris can plug the orifice tube or expansion valve. This can block the flow of refrigerant and lubricating oil causing a loss of cooling and possible compressor damage. Flushing the system is the best way of removing residual oil and contaminants, when performing a compressor replacement.

Flushing can help prevent repeat compressor failures and system blockages by dislodging and cleaning out sludge and debris. Replacing badly contaminated parts such as the condenser, accumulator or receiver-drier and orifice tube or expansion valve is another way to get rid of these contaminants, but flushing is usually more economical choice. Regardless of which approach you use, the orifice tube or expansion valve should always be replaced when contamination is found.

Sludge is usually the result of moisture-contamination. The blackish goo that results can damage the compressor and plug the orifice tube or expansion valve. The moisture-absorbing "desiccant" in the accumulator or receiver-drier is supposed to prevent this from happening. But the desiccant can only hold so much moisture. Once saturated, sludge begins to form

Another reason for flushing is to remove residual lubricating oil from the system.

The basic concept behind any flush job is to remove the oil and contaminants from the A/C system. In most cases, contaminants and debris will 'stick' to the oil. If you can remove all the oil, you will remove all the contamination.

Regardless of the type of A/C system you are flushing, never attempt to flush the compressor, accumulator or receiver drier. Orifice tube, filter drier and accumulator must be replaced.

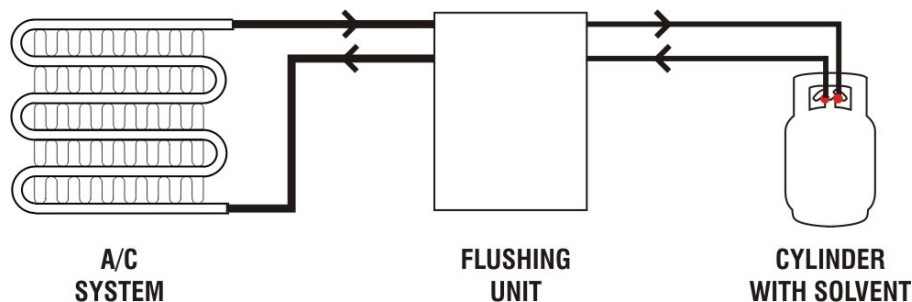

Flushing unit works on the principle of pulsing operation during the cleaning process. The solvent is recovered within the machine and the purified solvent returned into the cylinder. This flushing procedure ensures effective and fast cleaning out of difficult contamination.

Using high-pressure, up to 8 bar, particles and soot are forcefully flushed out. A special pulsing operation applies additional abrasive degreasing action to remove soot and dirt from crevices and corners. Due to its low boiling point the solvent can easily be recovered from the equipment and leaves it dry and clean.



Eko-Flush K570

Workshop units for use in larger service and repair shops, and automotive garages

This unit can conveniently be used for systems up to 20 L volume.

Specifications:

Connection with the flushed device 3/8" SAE (5/8" UNF)

Power supply: 230V/50Hz

Maximum power input: 1350W

Dimensions: 570x605x950mm

Weight: 54kg

Leak Test & Detection Equipment

Leakage of refrigerant from a/c system affects the performance of a sealed system. Both suction as well as discharge pressures reduce due to loss of refrigerant. Due to lower suction pressures, the lubricating oil return becomes difficult. In addition to this possibility of oil leaking with refrigerant may lead to the damage of the compressor. If the suction pressure due to refrigerant leakage falls below atmospheric pressure, then there is a possibility of air leaking into the system. This will bring moisture into the system and cause internal components to corrode.

There are 2 main methods for leak test the a/c system:

Leak Test under Vacuum. When a vacuum is drawn (minimum 1000 microns or lower) on the system and the vacuum pump is then turned off, it is a good practice to allow the system to sit for about 20-30min with the gauges connected to monitor. If vacuum is lost during this time, it indicates a leak is present. Note that the vacuum test is not conclusive. System may have leaks under vacuum that do not appear under normal system pressure, and vice-versa. Still, it's not a good sign.

Pressure Hold Leak Test. The most reliable method for leak testing the automotive A/C system is using nitrogen. For a complete A/C system test, the system should be pressurized to 15bar (200 psi) with nitrogen. Allow the system to sit for at least 20-30 minutes. If there is no degradation in the pressures, the A/C system is free of leaks. Nitrogen MUST be used with care and caution, because it is packaged under extreme pressures as a bottled gas. Nitrogen regulator is required in order to regulate and control the pressures of nitrogen that you put into the A/C system. For best results, it is suggested that the nitrogen be connected to the A/C system through a set of manifold pressure gauges.

Nitrogen can also be used for purging excess moisture from A/C systems and for flushing. Nitrogen is known to be a very dry and inert gas. What's best is that nitrogen will not cause any other problems with components nor will it react with any oils or other contaminants that may be found in the A/C system.



Nitrogen Pressure Test Kit

Both tests (under vacuum or pressure hold) will not show exactly where the leak is located. This type of check is only useful to verify whether the system has a leak or not.

Leak Detection Methods

Visual Leak Detection

When a refrigerant leak occurs, it is common in some cases for the lubricant oil to escape with the refrigerant. The presence of oil and encrusted dust around hose fittings, joints and components will indicate a leakage point.

A mixture of dishwashing liquid and water applied around the pressurised A/C system pipes and fittings will form bubbles at the leakage points.

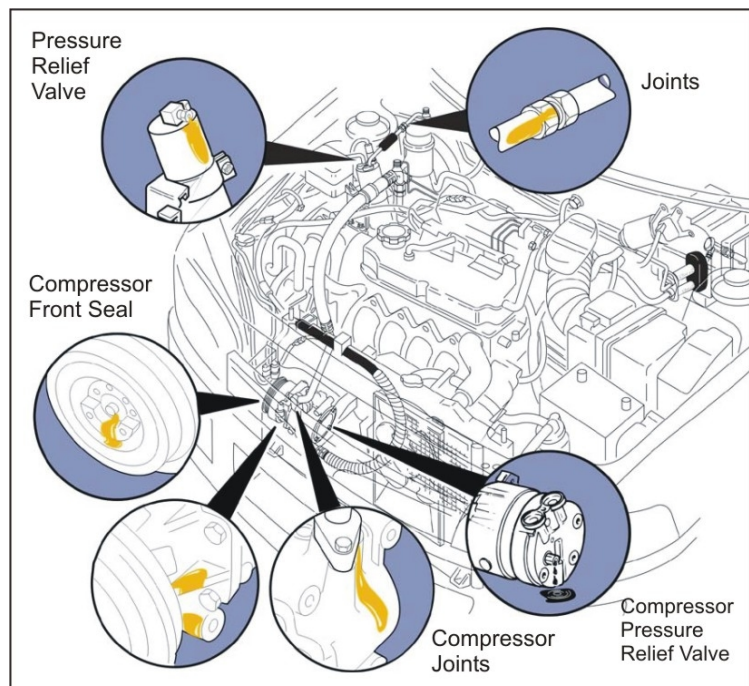
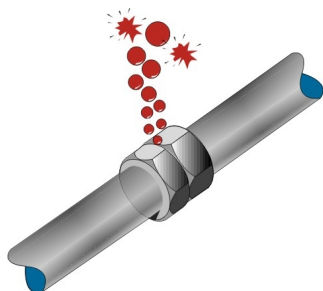

Electronic Leak Detector

These leak detectors operate in various ways. The most common being that when the unit is turned on, a low ticking sound can be heard and once the probe locates a leak, the ticking sound increases to a high pitched noise. This can be achieved by moving the sensing tip slowly around the underside of components and fittings at a distance of approximately 5-10 mm.



Sensing Tip

Important: DO NOT allow the sensing tip to contact components or fittings as false readings and tip damage will occur.

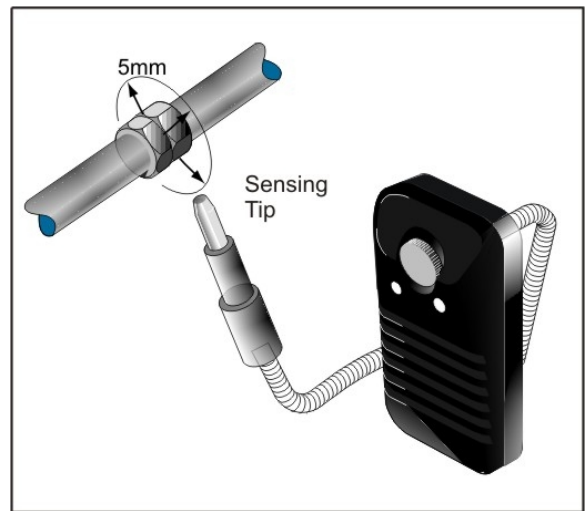

Ultraviolet Fluorescent System

A fluorescent coloured dye is injected into the A/C system and allowed to circulate with refrigerant. Then a specially designed ultraviolet lamp is passed over each component in the A/C system. If a leak is evident, the coloured dye glows yellow bright. This method is exceptionally good for pin pointing a small leak.

It is advisable to ask the customer to return in approximately one week time as the dye could take longer to emerge if the A/C system has a small leak.



Enhancing Goggles

UV Lamp

UV Dye

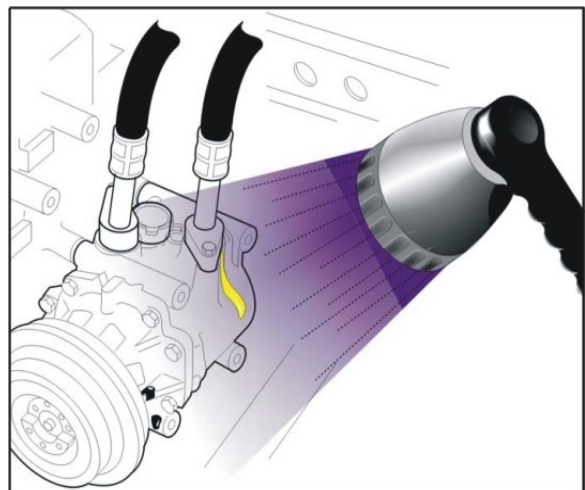

Refrigerant Identifier

The best defence against unknown refrigerant, and the risks associated with unknown refrigerant, is a refrigerant identifier. Use a refrigerant identifier any time a refrigerant mixture is suspected.

The main function of the refrigerant identifier is to assist the servicing technicians to check the purity of refrigerants in storage cylinders or directly in vehicle air conditioning systems. These devices typically detect R12, R134a, R22, air, and hydrocarbons. It also determines and controls the purging of ambient air-based Non Condensable gases (NCG) from refrigerant storage vessels or vehicle air conditioning systems.



Printed report

LCD screen

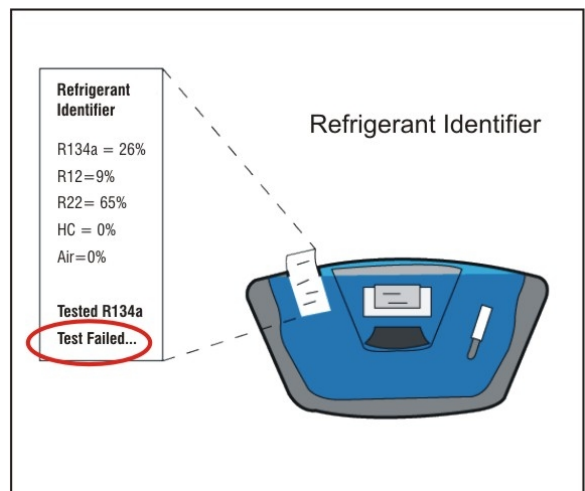

Other Measuring Instruments



Mini R134a Identifier

Economy identifier for verifying the quality of R-134a refrigerants in automotive a/c systems. It checks and verifies with a “GO” or “NO GO” signal.



Digital Thermometer with probe



Digital IR Thermometer

This can be used for measuring the temperature of registers and grills as well as ambient temperatures



Electronic vacuum gauge

The instrument reads from vacuum levels of 12,000 micron to ... “0”, and may be used in ambient temperatures from 0°C to 50°C.



Variable Displacement Compressor Tester

It controls the clutch-less variable compressors. By controlling the displacement (independent from the onboard computer) a more precise diagnosis can be made on the system.



Pressure Switches Tester

Tester for checking gas pressure switches. Includes adapters for the most common gas pressure switch thread sizes.



Digital refrigerant pressure/temperature chart

This instrument offers fast and accurate temperature references on a large and LCD display.



Sound Level Meter

To quantify sound level.



Electronic Scale

For weighing refrigerant cylinders



Nitrogen / Hydrogen Tracer Gas Leak Detector

It utilizes a solid-state heated sensor designed to be highly sensitive to Nitrogen/Hydrogen tracer Gas. The tracer gas mixture complies with Article 6, Paragraph 3 of EU Directive 2006/40/EC.

Universal Automotive A/C Tools



Universal Orifice tube remover kit

This set of tools makes it a snap to remove orifice tubes found in automotive air conditioning systems. Select the correct jaw, attach it to the handle and remove the tube by simply locking it onto the tool and pulling it out.

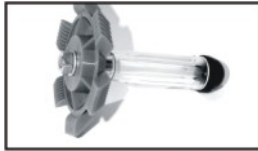

Fin Straightener

For alignment of condenser or evaporator fins.



Valve core remover

Valve core remover for standard & JRA valves.



Hose cutter

For cutting all common sizes of A/C hoses.



Sight glass a/c diagnose

Convenient instrument to make the refrigerant flow visible. This gives an indication about: Presence of leak "stop" substances, Compressor damage caused by metal particles and shavings, Quality of the refrigerant oil...



Compressor seal service set

Special tools are required when replacing seals on the compressor.



Clutch tool kit

Universal tool kit for assembly & disassembly of clutches on most used compressors.



Spring-lock tool kit

Spring-lock coupling disconnect tool for Ford, Hyundai, Volvo, Peugeot and Citroen.



Hose Crimping Equipment

Covers all 4 standard hose dimensions.



Thread chaser kit

To re-align damaged threads on A/C specific fittings. Thread chaser kit with various chaser sizes for making female and male thread like new again.

Universal A/C Assortments



O-ring assortment

Universal HNBR O-ring kit for a/c systems.



Valve core set

7 different valve core and 1 small valve core remover.



Orifice tube assortment

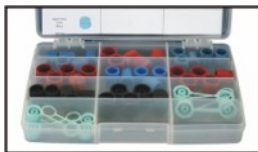

Valve cap assortment

10 different valve caps.



GM seal & gasket assortment

An assortment of hose gaskets for GM com-pressors. Six different types, four of each type.

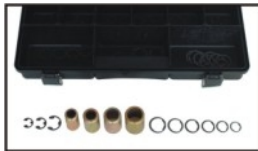

Hose Ferrule set

Assortment of replacement crimp sockets in the standard hose sizes 6, 8, 10, and 12.

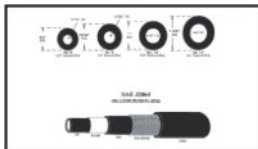

Standard A/C Hose

Hose size 6, 8, 10, 12 per meter.



Compressor Guard Assortment

New or reconditioned compressors are regularly damaged by metal shavings or dirt particles left in an air conditioning system. A simple screen in the suction line of the new compressor can prevent this from happening. Easy to install without cutting lines.



Foam Tape

Used for the protection and insulation of various air conditioning parts.

Compressor Oil





The purpose of compressor oil is to provide lubrication for the compressor. It helps compressors to last longer by providing enough grease that inhibits friction between the bearings, vanes, and rotor. Manufacturer of the vehicles or compressors determines the viscosity and lubricant type. Use of the correct lubricants is critical for proper system performance, durability, and longevity.

There are four major a/c compressor oils in the market today and these are:

- **Mineral oil** used in old R12 systems only.
- **PAG oil (Poly-alkaline-glycol)** used in original equipment passenger car and light truck HFC-134a systems.
- **POE oil (Poly-ol-ester or Ester for short)** is synthetic lubricant specified by few vehicle manufacturers.
- **PAO oil (Poly-alpha-olefin)** is synthetic oil. It is new in the market and slowly becoming popular. Its trademark is "one size fits all", because its viscosity level is compatible with almost all types of a/c system oils and additives, as well as with most compressors.

There are few viscosities or thicknesses of compressor oil: ISO 46, ISO 68, ISO 100, ISO 150. The smaller number indicates less viscous oil.

Important: Most A/C compressors used in Hybrid or Electrical vehicles are driven by a high voltage electric motor. Only the non-conductive lubricating oil (POE or PAO) can be used as the windings in these electric motors are exposed to the A/C system lubricating oil. Even a small amount of PAG oil can damage the high voltage insulation in an electric compressor.

MINERAL oil	PAG oil (Poly-alkaline-glycol)	POE oil (Poly-ol-ester or ester)	PAO oil (Poly-alpha-olefin)
			
R12 - Compatible R134 - NON Compatible	R12 – NON Compatible R134 - Compatible	R12 - Compatible R134 - Compatible	R12 - Compatible R134 - Compatible
Hygroscopic	Hygroscopic	Hygroscopic	NON Hygroscopic
NON COMPATIBLE with other lubricants	NON COMPATIBLE with other lubricants	NON COMPATIBLE with other lubricants	COMPATIBLE with other lubricants
MISCIBLE May not prevent oil logging	MISCIBLE May not prevent oil logging	MISCIBLE May not prevent oil logging	LOW MISCIBILITY Prevents oil logging
POOR High Temperature Viscosity Properties	FAIR High Temperature Viscosity Properties	FAIR High Temperature Viscosity Properties	SUPERIOR High Temperature Viscosity Properties
NON AGGRESSIVE	AGGRESIVE	AGGRESIVE	NON AGGRESSIVE
Electric Compressors NON Compatible	Electric Compressors NON Compatible	Electric Compressors Compatible	Electric Compressors Compatible

Component replacement

When replacing components, check the manufacturers recommendations on the quantity of oil to be added to the new components before installation. This is normally found in the particular vehicle workshop manual.

EXAMPLES of approximate quantities:

- Evaporator – 40ml
- Filter drier – 20ml
- Condenser – 30ml
- Accumulator – 40ml
- Hoses – 20 ml
- Tubes – 20ml

Insufficient oil in the system will damage the compressor due to lack of lubrication, but excess oil will collect in the condenser and prevent proper cooling performance.

If the compressor sounds as though it needs lubricating, it probably does. Check the system for debris, and replace the compressor if needed.

If cooling performance is poor despite several recent repairs, the system may contain excess lubricant, especially if oil was added to the system without draining and measuring all the oil.

Compressor (new replacement)

Drain and measure the lubricating oil from removed compressor. Likewise, remove the oil from the new compressor, refill this new compressor with the same quantity of oil drained from the old compressor.

On compressors without inspection plugs, add oil to compressor through the discharge and suction ports, **turn the compressor hub several times by hand to make sure no oil is trapped in the compressor chambers.**

Use the new clean oil removed from the new compressor plus 10cc to allow for any internal oil.

Receiver Driver -20ml

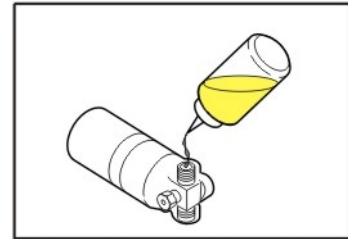

Compressor - 10ml

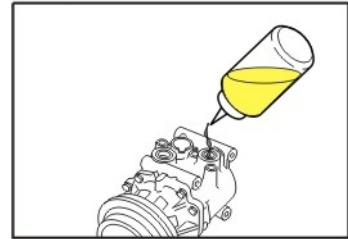

Hoses - 30ml



Condenser - 30ml

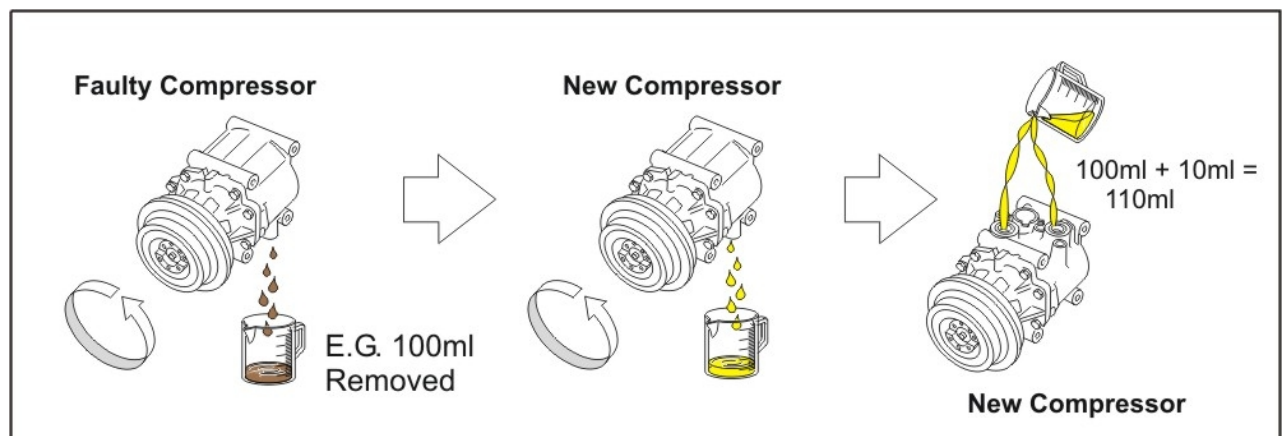
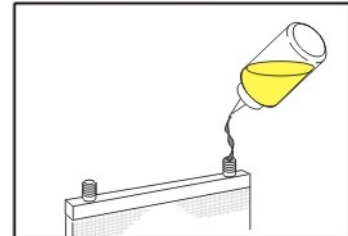

Refrigerant Safety

As R134a has a very low boiling point, care must be taken when it is been handled. The following safety precautions must be followed:

- Always wear eye protection.



- Wear gloves for Hand/Skin Protection. Don't allow R134a to contact bare skin as this causes frostbites.



- Do expose refrigerant containers to open flames, red hot surfaces, or temperature above of 50°C.



- Provide adequate ventilation when charging or recovering refrigerant as it is heavier than air. Avoid breathing R134a vapour.

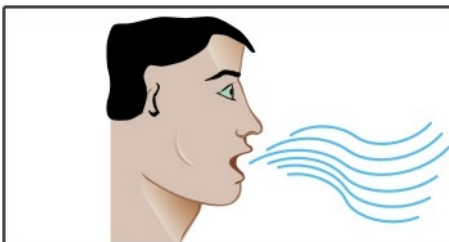

- Use care when hot water steam cleaning the engine. Hot water on the air conditioning pipes and tubes could create thermal expansion of the refrigerant contained in the system.
- Do not transfer refrigerant from cylinder to cylinder using a pump without knowing when the bottle being filled has reached 80% of its capacity, as a remaining 20% is used for thermal expansion.
- Do not transport refrigerant containers in the passenger compartment of a vehicle.
- Do not puncture or incinerate refrigerant containers.

R134a – HFO 1234yf Handling and Service Differences

Starting in 2012 vehicles with air conditioning systems running on the new 1234yf refrigerant will enter the European market. However, the great majority of vehicles on the roads will still be using the older R-134a refrigerant – and these will continue to require servicing for the next 15 years or so.

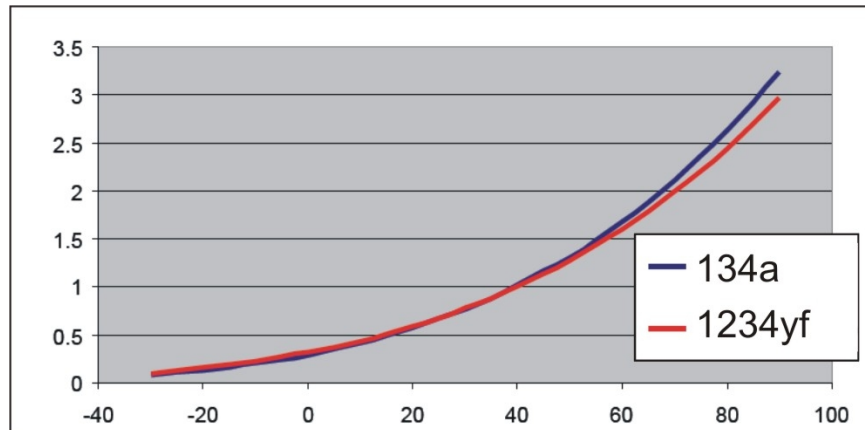

HFO-1234yf has vapour pressure, toxicity class A, similar to R-134a, but has mild flammability

HFO1234yf is mildly flammable. Precautions used with other flammables (gasoline, oil) are applicable to 1234yf. In general, low lying areas, (such as workshop pits, shafts or cellar exits), may cause released refrigerant to pool as it is heavier than air. Current regulations require work areas to be adequately ventilated and extraction units switched on if available.

Service technicians should not smoke or have any open flame present while working on refrigerant containing systems



R134a
Light blue cylinder

Both disposable and returnable containers available.



HFO 1234yf
White cylinder with red band

Both disposable and returnable containers available.

Refrigerants should always be stored in a cool, dry location, out of direct sun light.

To prepare for HFO1234yf service technicians will need:

- New 1234yf recovery/recycle/recharge equipment
- New refrigerant identifier to allow the workshop to monitor the type, quality and purity of a given refrigerant.
- New leak detection equipment capable of identifying leaks of the new refrigerant in the vehicle's air con system.
- Assure adequate ventilation and follow flammable storage practices.
- Appropriate technician training

HFO1234yf refrigerant system components should not be replaced with ones removed from a system that uses another type of refrigerant, or from a salvaged vehicle.

Lubricants used with HFO1234yf systems may be different than those currently used. hybrid compressors, driven by high voltage electric motors, or equipped with hermetic mobile A/C systems, use different oils. Necessary to check oil requirements.

Air Conditioning Performance Testing (General)

This procedure describes methods for testing and inspecting air conditioning systems. Before servicing or diagnosing an A/C system there are preliminary checks that should take place.

STEP 1. Park the vehicle in a shaded area. Open the vehicle doors or windows to vent the interior. Record the ambient temperature and relative humidity.

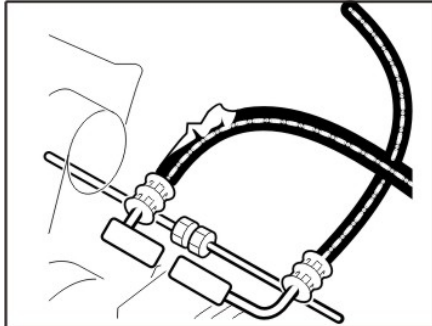

STEP 2. Visual checking for hose damage. Inspect all connectors for signs of leakage or oil. Look for kinks, bends, or weather cracking.

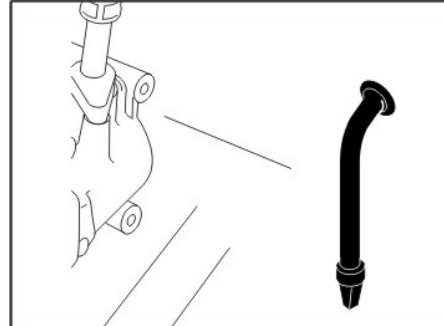

STEP 3. Visual checking for damage on compressor housing. Inspect drive belts for correct tension and damage. Evaporator drain hose not blocked.

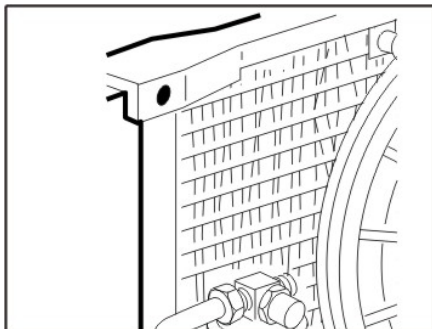

STEP 4. Ensure the condenser cooling fins are not blocked with obstructions such as insects, leaves or grass. Condenser fan operates and runs in correct direction.

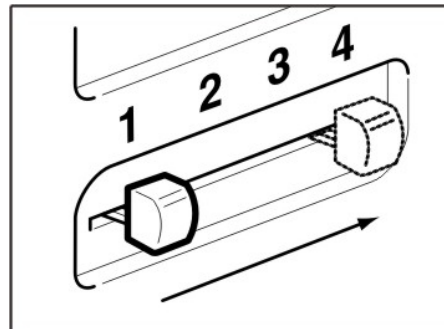

STEP 5. Set the controls to: Fresh air position; Maximum cooling; Highest blower speed;

STEP 6. Place a thermometer in the air outlet nearest the center of the dash for record of discharge air temperature.

STEP 7. Connect both high and low pressure service hose coupling valves of service unit to the system filling ports.

STEP 8. Set the transmission in neutral and start engine. Turn the A/C on and bring engine speed to 1500 RPM then allow pressure gauge needles to stabilize.

STEP 9. Record the pressure and temperature readings. Compare this to the performance charts. Note: Take pressure and temperature readings when the compressor is engaged.

Ambient temperature (°C)	Discharge air temperature °C	Low Side Pressure (bar)	High Side Pressure (bar)
20	4-10	1.6 – 2.2	10 – 13
25	5-12	1.7 – 2.4	11 – 15
30	6-13	1.8 – 2.6	12 – 17
35	8-14	1.9 - 2.8	13 – 19

If the system performance is less than described on the performance chart, make necessary repairs, perform the leak test.

Pressure gauges

An accurate diagnosis and determination of air conditioning system function and more importantly, malfunction, depend largely upon the ability of the technician to interpret gauge pressure reading. The importance of a gauge set is often compared to that of a doctor's stethoscope.

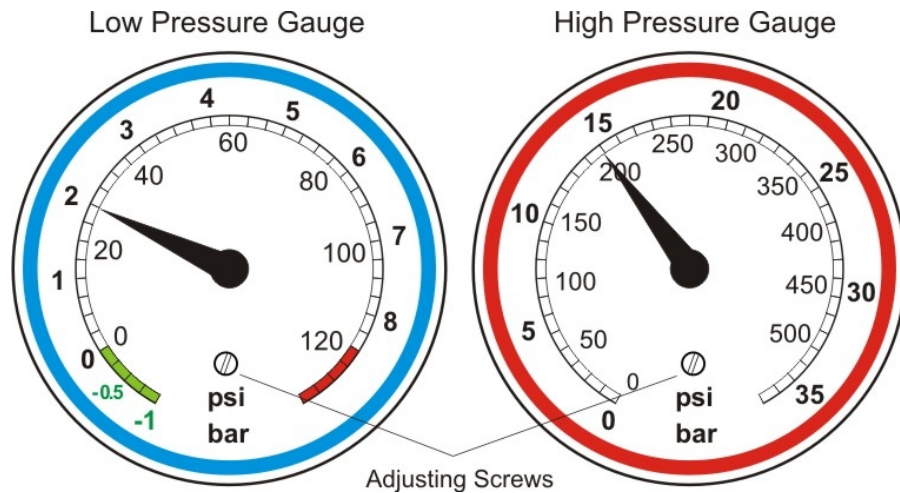

An improper gauge reading will relate to a specific problem. More than one problem may be associated with particular gauge reading, however. A system operating normally will have a low-side gauge pressure reading that corresponds with the temperature of the liquid refrigerant as it becomes a vapor while removing heat from the air flowing over the evaporator coil surface. The high-side gauge readings should correspond with the temperature of the vapor as it becomes a liquid while giving up its heat to the ambient air flowing through the condenser.

Any deviation from ambient dependant normal gauge readings, other than slight, indicates a malfunction. This malfunction, if within the system, may be caused by a faulty control device, a restriction, or defective component. It should be noted that improper mounting or location of components in a newly installed system may affect system performance. The vehicle engine may also affect system performance and will be note as abnormal gauge readings.

Pressure gauge pre check

Always inspect pressure gauges to ensure the needles rest as zero on both low and high sides on atmospheric pressure. If the needle(s) do not rest on zero, remove the hoses, open both taps, detach the dial face and gently turn the adjustable screw until the needle(s) rest on zero. Reconnect hoses and close taps.

Pressure gauges readings in normal condition

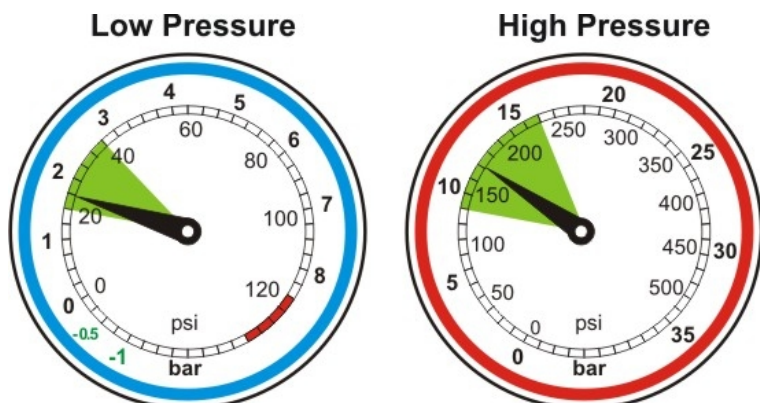

Gauges show normal operation of A/C system.

If the pressure readings to the ambient temperatures are different to these, then the system is probably defective.

Important: Pressure gauge readings (low & high) depends on ambient temperature.

1. Low Pressure (Suction) vs. Ambient Temperature

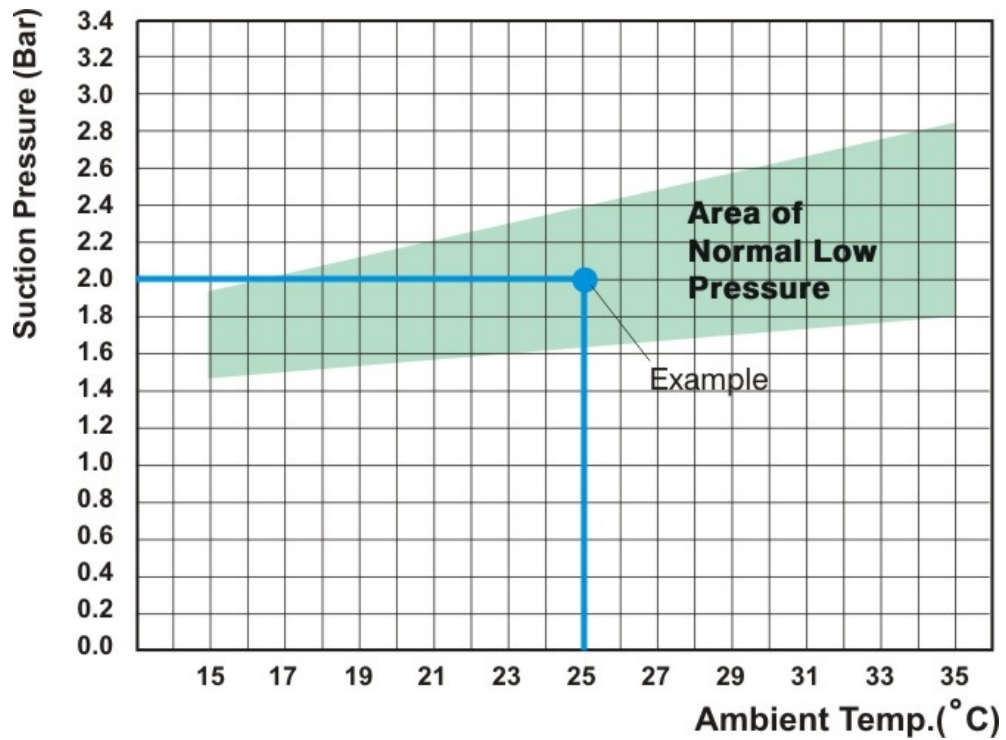

Example:

The outside temperature is 25 °C. The suction pressure we have measured is 2 Bar (30psi). The graph shows that the point is in the area of normal pressure.

2. High Pressure (Discharge) vs. Ambient Temperature

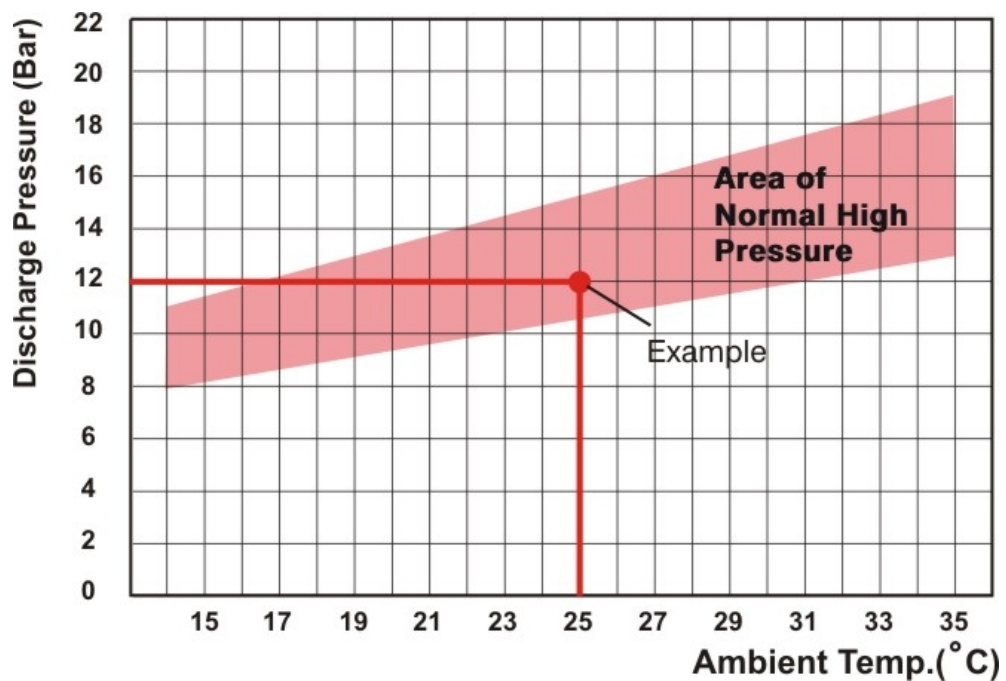

Example:

The outside temperature is 25 °C. The discharge pressure we have measured is 12 Bar (170psi). The graph shows that the point is in the area of normal pressure.

Faulty performance of A/C system

As we have mentioned before, correct pressure gauges reading may show particular problem or associate to a possible problems.

Note: (F) fixed displacement compressor, (V) variable displacement compressor

Pressure readings are normal, A/C system is not cooling.

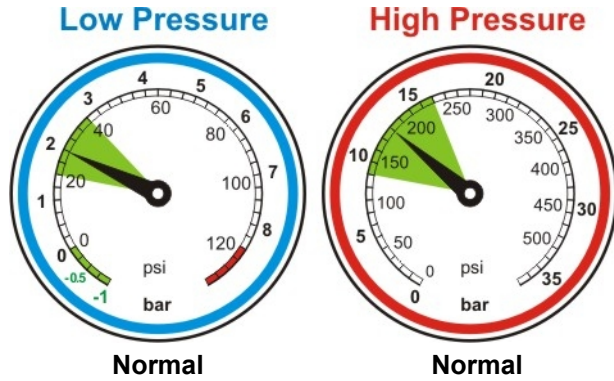

Probable Causes

- Warm air infiltrated into the evaporating unit or passenger compartment.
- Warm water infiltrated in the heater.
- Ice on evaporator core.

An A/C system that blows cold air for awhile then warm air is probably freezing up. This can be caused by air and moisture in the system that allows ice to form and block the orifice tube.

Low Pressure - Low, High Pressure - low

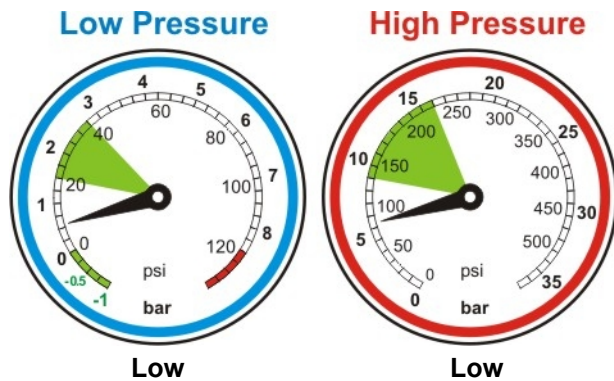

Probable Causes

- Normal situation if ambient temp. is very low.
- Too little refrigerant quantity. Check for leaks.
- Expansion valve (or orifice tube) stuck partially closed or blocked.
- Blockage between filter and evaporator.
- Blockage in the H.P. branch between compressor and condenser-filter hose, but before the H.P. reading point.

Low Pressure - High, High Pressure - High



Probable Causes

- Normal situation if ambient temp. is very high.
- Excess refrigerant charge, 30% more.
- Condenser overheated. Faulty condenser fan (slow or no rotation).
- Air present in the A/C system. More than 6% air can cause a big drop in cooling performance.
- (V) Compressor displacement regulator valve defective.
- Blockage in the H.P. branch between compressor and condenser filter hose, but after the H.P. reading point.

Low Pressure - High, High Pressure – Low (Low Press. approximately equal to High Press)

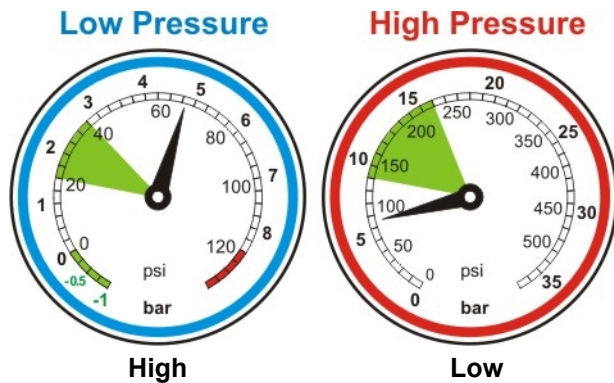

Probable Causes

- Electric clutch of the compressor not engaged. If the voltage to the clutch is low, or the clutch coils have too much resistance, the clutch may not engage to drive the compressor. Also check to see if the clutch relay is receiving voltage when the A/C is turned on.
- Compressor belt jumped. Probably caused by misalignment of the pulleys.
- Compressor damaged.
- (V) Compressor displacement regulator valve defective.

Manual A/C systems.

- Faulty low pressure cut-out switch. This switch prevents the compressor from running if the refrigerant level is low.

Automatic A/C systems.

- Problem in the control module, or bad sensor (an ambient air temperature sensor, interior air temperature sensor, evaporator temperature sensor, or sun-load sensor).

Low Pressure - High, High Pressure – Low or Normal



Probable Causes

- Suction and drainage hoses reversed on compressor.
- Electric clutch of the compressor not engaged.
- Expansion valve stuck open. If the compressor is "variable displacement type", the low pressure has small but fast oscillations.
- (V) Compressor displacement regulator valve incorrectly set or defective
- Compressor damaged

Low Pressure - Low, High Pressure – High or Normal

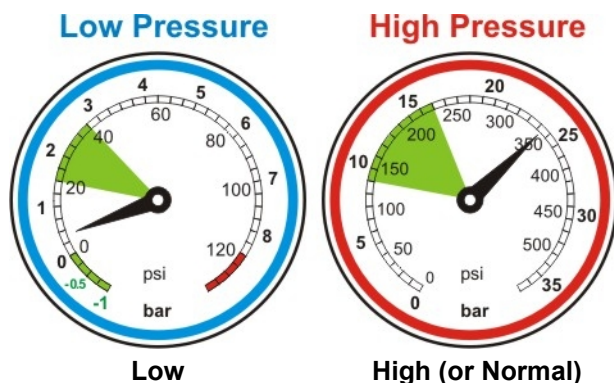

Probable Causes

- Filter saturated with moisture
- (V) Compressor displacement regulator valve stuck at maximum displacement.
- (F) Blockage in H.P. or L.P. branch between filter and evaporator.

Troubleshooting and Solutions

A/C system is noisy

The noise heard when the A/C system is first turned on is not due to a defect. In the event of persistent noise, check for the presence of one of the following malfunction causes and apply the corresponding solution.

CAUSE	SOLUTION
1. Belt worn or slipped	1. Check the wear and tension of the belt.
2. Belt idler pulley is noisy	2. Replace it.
3. Electric clutch plate slipping	3. Make sure that the distance between the compressor pulley and electric clutch is 0.3-0.5mm.
4. Vibration and resonance of the compressor support plate.	4. Make sure the bolts are tight and the plate is properly positioned.
5. Expansion valve "whistles".	5. If the noise persist, replace the valve.
6. Noise caused by hoses or other parts rattling against other components in the engine compartment.	6. Check the routing of the hoses, support brackets, etc., to pinpoint the noise.

Few defective components of the A/C system create an incorrect inlet and outlet pressure. This causes noise in the compressor that is actually due to one of the causes listed below and NOT to the compressor itself.

- Incorrect amount of refrigerant (30-35% more or 70-75% less).
- Expansion valve stuck shut or blocked.
- Compressor displacement regular valve defective (for variable-displacement compressors only).
- Clogging in the A/C system circuit.
- Filter saturated with moisture.

A/C system emits unpleasant smell

Under certain conditions, moulds and bacteria (normally present in the air) may form on the surface of the evaporator core, causing an unpleasant smell inside the vehicle. Besides smelling bad, it can be unhealthy to breathe.

- Various chemicals and antibacterial can be sprayed on the evaporator directly or through the blower ducts or air intake. Many replacement evaporators have a special chemical coating that inhibits the growth of mold and bacteria. The drainage tubes that carry condensation away from the evaporator should also be inspected and cleaned.

- Advise the customer to turn off the A/C system a few minutes before shutting off the vehicle, leaving the blower fan running (this will dry the evaporator core from the moisture that encourages bacteria growth).

The condenser does not dissipate enough heat (overheated condenser)

CAUSE	SOLUTION
1. Air flow blocked by dirt accumulated on the heat exchangers; water radiator, condenser.	1. Clean the radiator and condenser thoroughly.
2. The pressure switch or water temperature bulb are not tripped at the correct pressure and temperature levels.	2. Cut out the controls using the appropriate electrical connection. Replace the defective part if necessary.
3. The electric fan does not work	3. Power the electric fan directly. Replace if it still does not work.
4. Incorrect functioning by the electric fan (incorrect rotation direction).	4. The fan must be "suction" type when placed between the heat exchangers and the engine, and "blowing" type if placed between the heat exchangers and outside air intake.
5. Engine water overheated	5. Make sure the original engine cooling system is working properly.
6. Condenser not positioned correctly.	6. Make sure that the distance between the radiator and condenser is 15-20mm, if present the air ducts must be correctly positioned.

Incorrect amount of refrigerant. Air or incondensable gases or moisture in the A/C system

CAUSE	SOLUTION
1. Incorrect refrigerant amount (30-35% excessive or 70-75% lack).	1. Recover refrigerant from the A/C system.
2. Contaminated refrigerant.	2. Replace the A/C filter (if filter is saturated with moisture).
3. Filter saturated with moisture.	3. Evacuate the incondensable gases and moisture from the A/C system. Run the vacuum pump for at least 30 minutes.
	4. Check the vacuum seal using a pressure gauge control.
	5. Charge the recommended amount of refrigerant to the system as well as any oil recovered together with the refrigerant.

Compressor displacement regulator valve defective (only for variable-displacement compressors)

CAUSE	SOLUTION
<ol style="list-style-type: none">1. Valve blocked by impurities (the evaporator tends to freeze)2. Regulator springs of the valve improperly set	<ol style="list-style-type: none">1. Recover refrigerant from A/C system.2. Replace the displacement regulator valve located in the compressor rear cover.3. Evacuate the incondensable gases and moisture from the A/C system by letting the vacuum pump run at least 15 minutes.4. Restore the recommended amount of refrigerant to the system as well as any oil recovered together with the refrigerant.

Expansion Valve Defective

CAUSE	SOLUTION
<ol style="list-style-type: none">1. Thermostatic capillary of the valve is defective.2. Mechanics of the valve are jammed.	<ol style="list-style-type: none">1. Recover refrigerant from the A/C system.2. Replace the expansion valve.3. Evacuate the incondensable gases and moisture from the A/C system by letting the vacuum pump run for at least 15 minutes.4. Charge the recommended amount of refrigerant to the system as well as any oil recovered together with the refrigerant.

The Electric Compressor Clutch Slips or Does Not Engage

Note: For valves equipped with automatic control (ECC), go to self-diagnostic or software control.

CAUSE	SOLUTION
1. Shortage of refrigerant (70-75% lack)	1. Search for the refrigerant leak
2. Electric clutch coil de-energized or intermittent energized	2. Disconnect the electrical clutch wire from the electrical system and connect it to the positive pole of the battery using a 7.5A fuse. If the clutch does not engage, it must be replaced. If it does engage, check the pressure switch, thermostat, A/C control switch, and miscellaneous electrical connections.
3. Incorrect distance between compressor pulleys and electric clutch plate.	3. The distance must be between 0.3-0.5mm

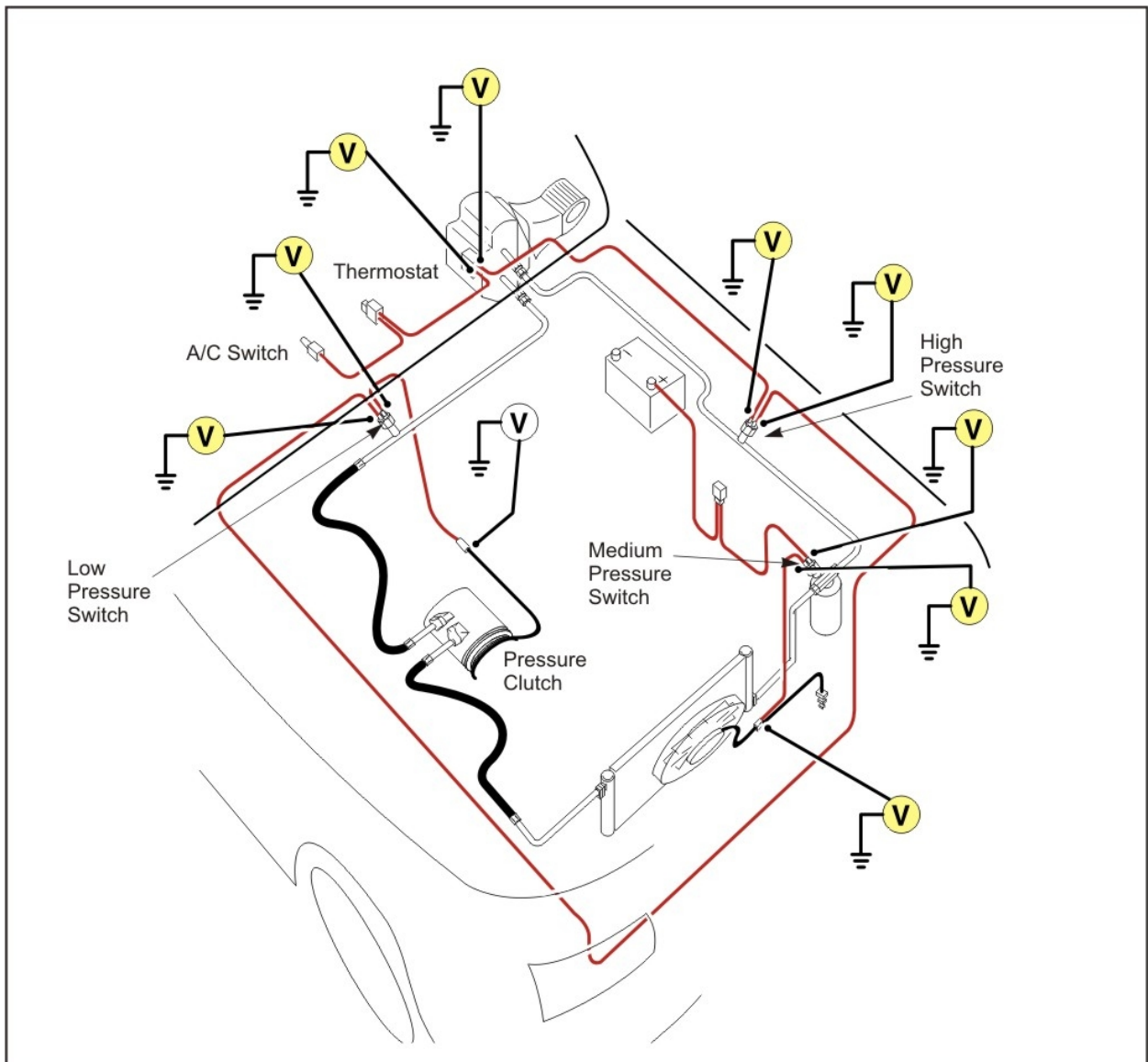

Ice on the Evaporator Core

Note:

- This may occur even after a few minutes of operation, causing a progressive drop in the air flow at the vents.
- For valves equipped with automatic control (ECC), go to self-diagnostic or software control.

CAUSE	SOLUTION
1. Malfunction by the thermostat or “no-frost” probe (if present).	1. Make sure the electrical connection of the thermostat or of “no-frost” probe is in good condition, and that the sensor is properly positioned. Replace any defective parts as needed.
2. Malfunction by the blower fan	2. With the A/C system running, at least the first ventilation speed must work. Otherwise, make sure the electrical system is properly connected.
3. Compressor displacement regulator valve is defective (only for variable displacement compressors).	3. Check the operation of the compressor displacement regulator valve.

Compressor Damaged

CAUSE	SOLUTION
1. Valves bent	1. Recover refrigerant from A/C system.
2. Seizing	2. Replace the compressor from A/C system.
	3. If the compressor is seized, flush the A/C system using a specific product and replace the dehydrator filter.
	4. Install a new compressor.
	5. Evacuate the incondensable gases and moisture from the A/C system by letting the vacuum pump run at least 30 minutes.
	6. Restore the recommended amount of refrigerant to the system as well as any oil recovered together with the refrigerant.

**Hot Air Infiltrated in the Passenger Compartment
Hot Water Infiltrated in the Heater**

CAUSE	SOLUTION
1. The water valve of the heater (if present) does not close properly.	1. Check the lever mechanisms and/or valve control motor. Cut out the heater if necessary.
2. The air mixing and/or re-circulating flaps are not perfectly sealed.	2. Check the lever mechanisms and/or valve control motors.
3. Sealing of the evaporator unit poorly airtight	3. Make sure the evaporator unit is tightly sealed and the couplings with the original heater are correct, to prevent warm air from infiltration from outside.

Blockage in the A/C system circuit

A very useful diagnostic aid is the “Feel Test”. As the test implies it is a matter of quite simply feeling tubes and components for temperature drops, indicating possible blockage location.

By this stage you would be aware of what side of the A/C system should be hot and what side should be cold. But what also happens with the pressure gauge reading, sometimes they don’t make sense.

The location of the charging ports in relation to the A/C system MUST be taken into consideration. A pressure gauge reading could be high or low depending on what side of the charge port the blockage is located. Use the “Feel Test” as well as the pressure gauges readings.

