

HONDA



The Power of Dreams

All New
AMAZE



HONDA

As you read this manual, you will find information that is preceded by a symbol **NOTICE**. This information is intended to help you avoid damage to your vehicle, other property, or the environment.

Symbols   on labels attached to your vehicle are to remind you to read this owner's manual for proper and safe operation of your vehicle.

 is colour-coded to indicate "danger" (red), "warning" (orange), or "caution" (amber).

 **Safety Labels** P. 69

A Few Words About Safety

Your safety, and the safety of others, is very important. And operating this vehicle safely is an important responsibility.

To help you make informed decisions about safety, we have provided operating procedures and other information on labels and in this manual. This information alerts you to potential hazards that could hurt you or others.

Of course, it is not practical or possible to warn you about all the hazards associated with operating or maintaining your vehicle. You must use your own good judgement.

You will find this important safety information in a variety of forms, including:

- **Safety Labels** - on the vehicle.
- **Safety Messages** - preceded by a safety alert symbol  and one of three signal words: **DANGER**, **WARNING**, or **CAUTION**. These signal words mean:

 **DANGER**

You **WILL** be **KILLED** or **SERIOUSLY HURT** if you don't follow instructions.

 **WARNING**

You **CAN** be **KILLED** or **SERIOUSLY HURT** if you don't follow instructions.

 **CAUTION**

You **CAN** be **HURT** if you don't follow instructions.

- **Safety Headings** - such as Important Safety Precautions.
- **Safety Section** - such as Safe Driving.
- **Instructions** - how to use this vehicle correctly and safely.

This entire book is filled with important safety information - please read it carefully.

Event Data Recorders*

Your vehicle is equipped with several devices commonly referred to as Event Data Recorders. They record various types of real time vehicle data such as SRS airbag deployment and SRS system components failure.

This data belongs to the vehicle owner and may not be accessed by anyone else except as legally required or with the permission of the vehicle owner.

However this data may be accessed by Honda, its authorised dealers and authorised repairers, employees, representatives and contractors only for the purpose of the technical diagnosis, research and development of the vehicle.

Service Diagnostic Recorders*

Your vehicle is equipped with service-related devices that record information about powertrain performance and driving conditions. The data can be used to help technicians diagnose, repair and maintain the vehicle. This data may not be accessed by anyone else except as legally required or with the permission of the vehicle owner.

However this data may be accessed by Honda, its authorised dealers and authorised repairers, employees, representatives and contractors only for the purpose of the technical diagnosis, research and development of the vehicle.

* Not available on all models

This owner's manual should be considered a permanent part of the vehicle and should remain with the vehicle when it is sold.

This owner's manual covers all models of your vehicle. You may find descriptions of equipment and features that are not on your particular model.

Images throughout this owner's manual represent features and equipment that are available on some, but not all, models. Your particular model may not have some of these features.

The information and specifications included in this publication were in effect at the time of approval for printing. Honda Cars India Ltd. reserves the right, however, to discontinue or change specifications or design at any time without notice and without incurring any obligation.

➤ **Safe Driving P. 25**

For Safe Driving P. 26 Seat Belts P. 30 Airbags P. 40

➤ **Instrument Panel P. 71**

Indicators P. 72 Gauges and Information Display P. 83

➤ **Controls P. 89**

Clock P. 90 Locking and Unlocking the Doors P. 91
Opening and Closing the Windows P. 109
Adjusting the Seats P. 126
Climate Control System * P. 143

➤ **Features P. 147**

Audio System * P. 148 Audio System Basic Operation * P. 153
General Information on the Audio System * P. 168

➤ **Driving P. 191**

Before Driving P. 192 Towing a Trailer P. 196
Refueling P. 224 Fuel Economy and CO₂ Emissions P. 228

➤ **Maintenance P. 229**

Before Performing Maintenance P. 230
Checking and Maintaining Wiper Blades P. 266
Cleaning P. 276

➤ **Handling the Unexpected P. 281**

Tools P. 282 If a Tyre Goes Flat P. 283
Overheating P. 298 Indicator, Coming On/Blinking P. 300

➤ **Information P. 313**

Specifications P. 314 Identification Numbers P. 318

Contents

Quick Reference Guide P. 4

Safe Driving P. 25

Instrument Panel P. 71

Controls P. 89

Features P. 147

Driving P. 191

Maintenance P. 229

Handling the Unexpected P. 281

Information P. 313

Index P. 320

Child Safety P. 47

Exhaust Gas Hazard P. 68

Safety Labels P. 69

Opening and Closing the Boot P. 105

Operating the Switches Around the Steering Wheel P. 111

Interior Lights/Interior Convenience Items P. 132

Security System P. 108

Adjusting the Mirrors P. 125

Heating and Cooling System* P. 137

Audio Error Messages* P. 167

Hands-Free Telephone System* P. 169

When Driving P. 197

Braking P. 217

Parking Your Vehicle P. 220

Maintenance Schedule P. 233

Checking and Maintaining Tyres P. 268

Accessories and Modifications P. 280

Maintenance Under the Bonnet P. 240

Battery P. 272

Replacing Light Bulbs P. 256

Remote Transmitter Care* P. 274

Engine Does Not Start P. 290

Fuses P. 303

Jump Starting P. 294

Emergency Towing P. 310

Shift Lever Does Not Move P. 297

Visual Index

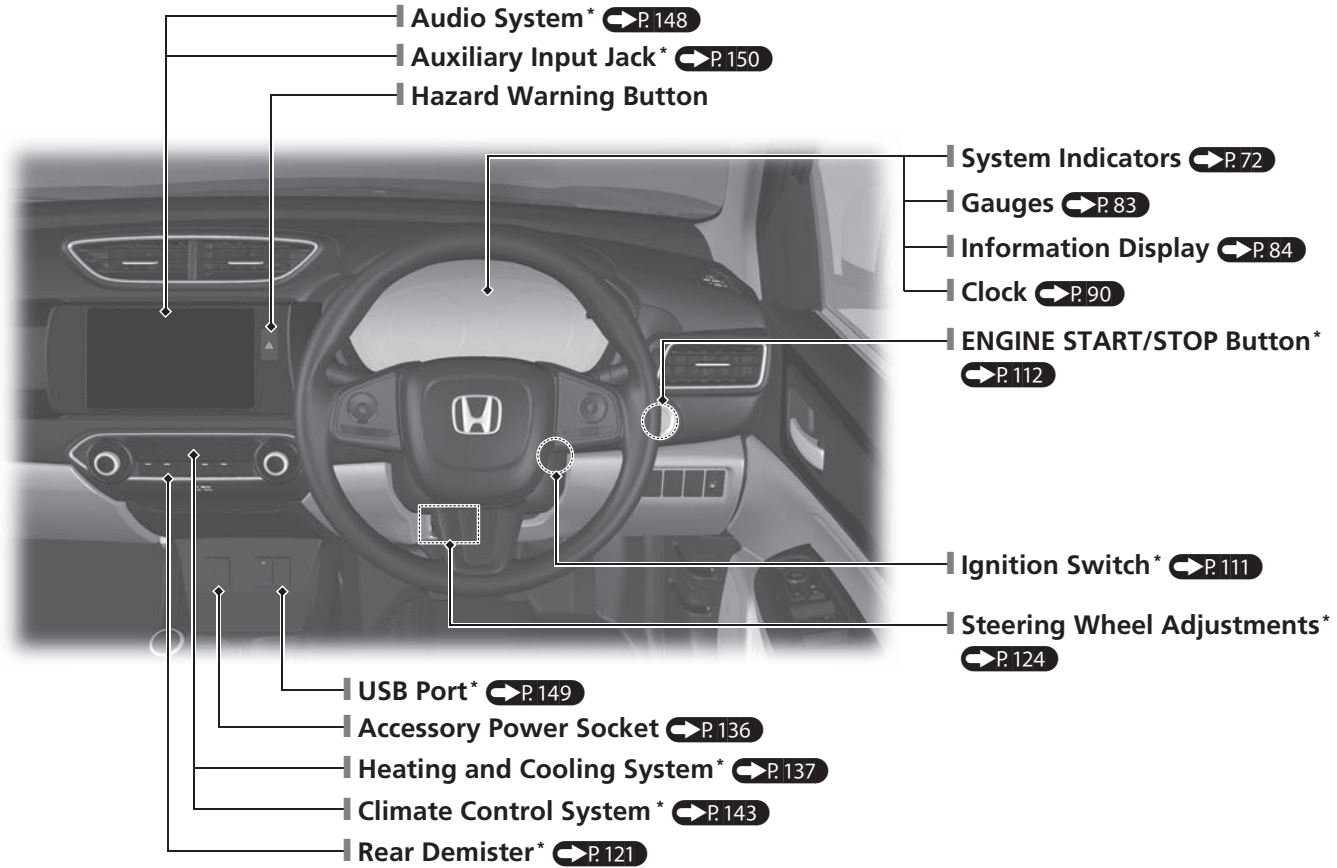

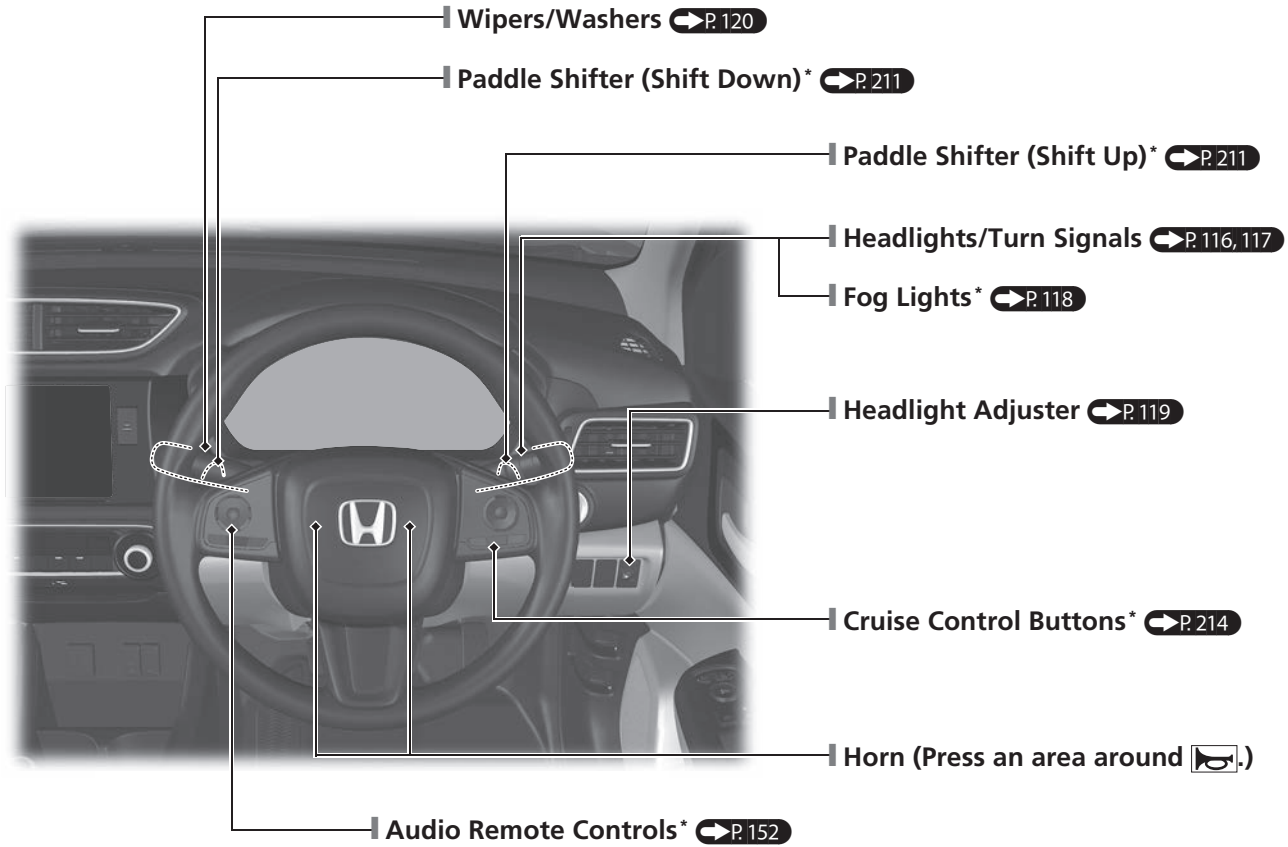

* Not available on all models

Visual Index

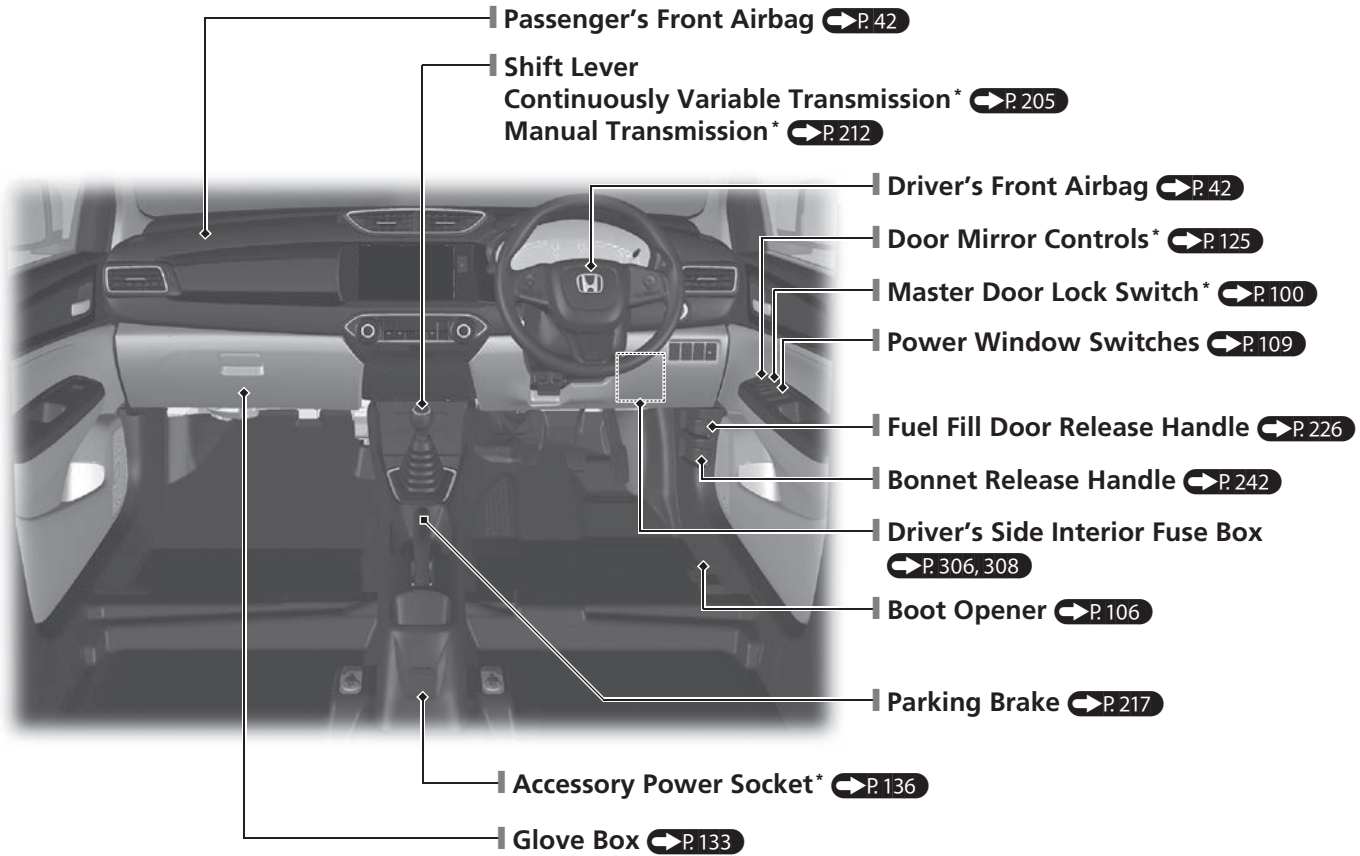

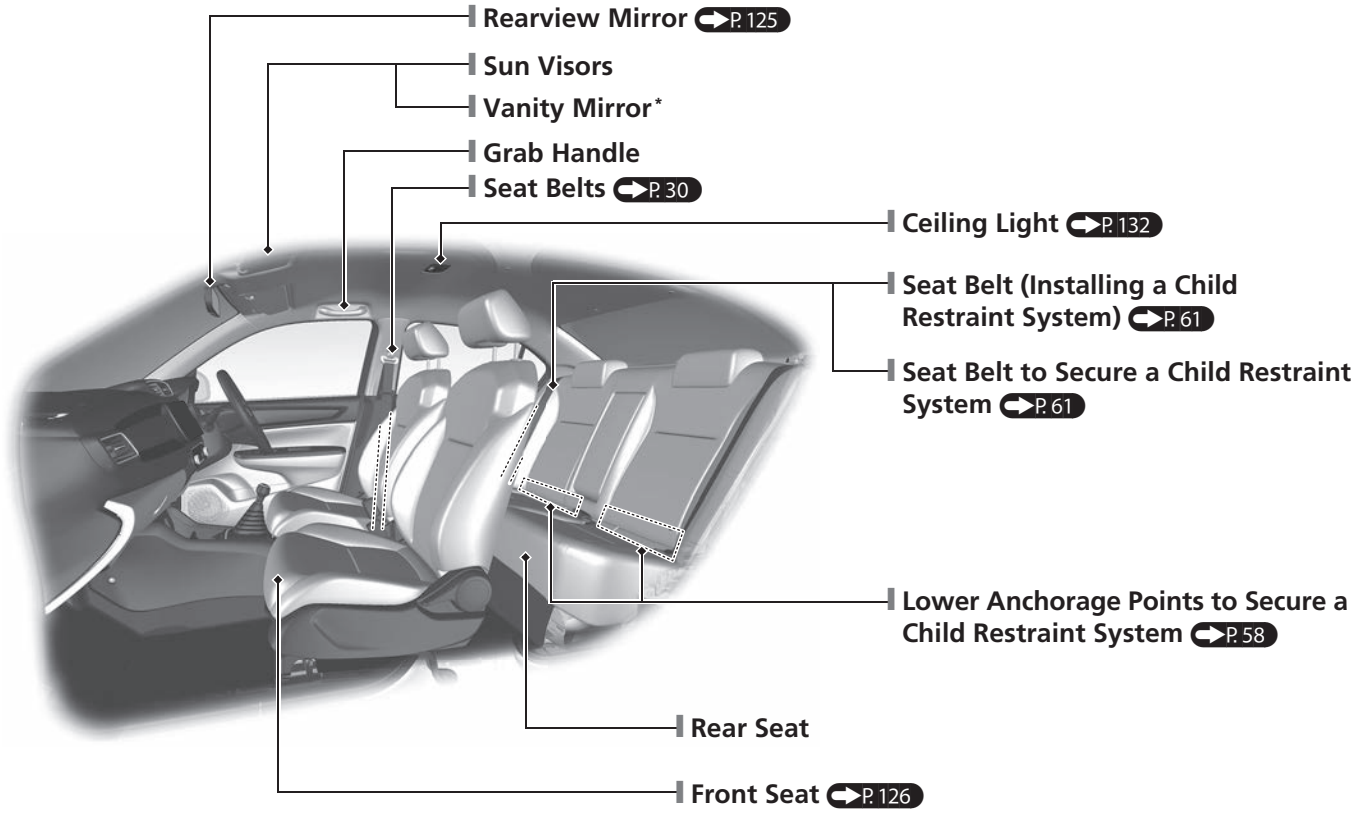

* Not available on all models

Visual Index

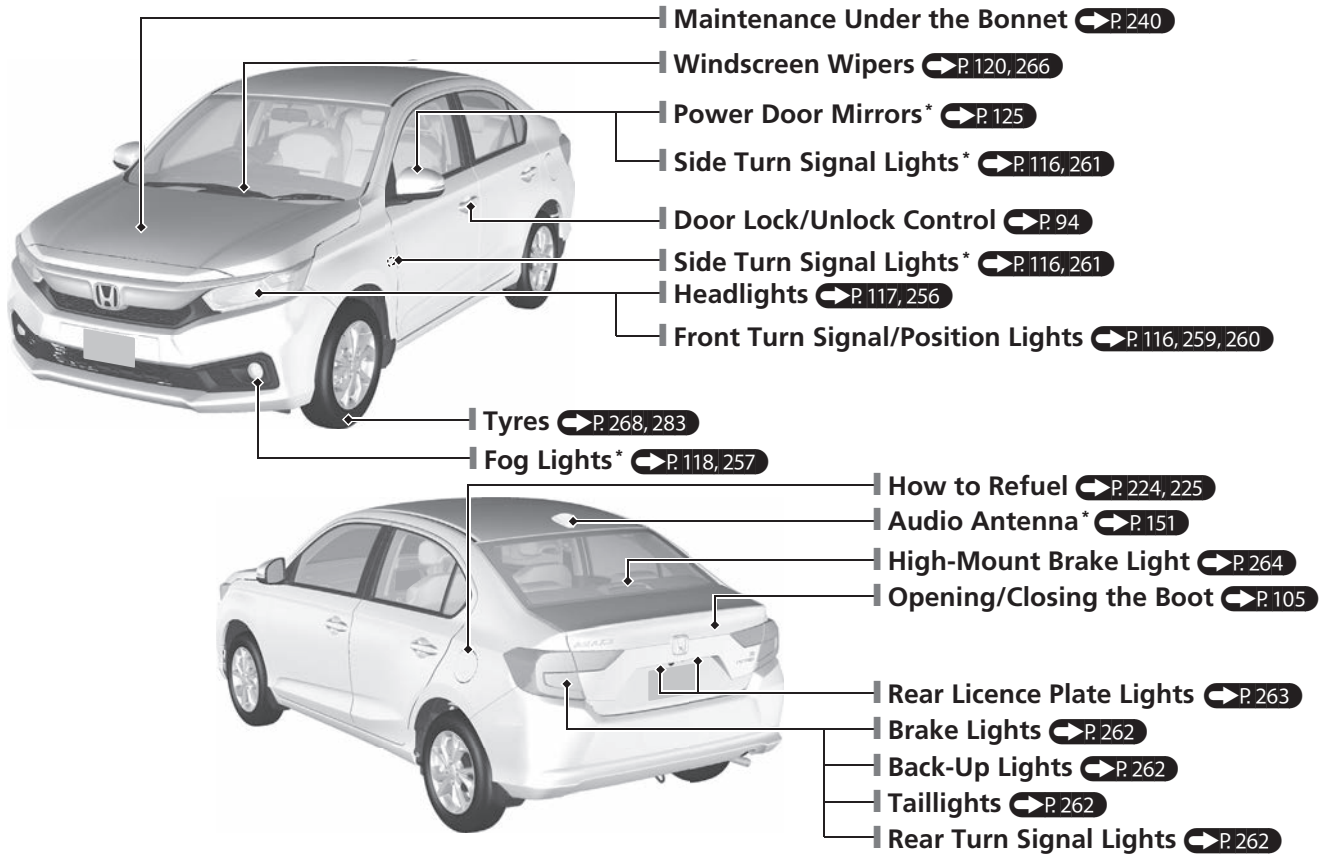

Safe Driving ➔ P.25

Before Driving Checklist ➔ P.29

- Before driving, check that the front seats, head restraints*, steering wheel, and mirrors have been properly adjusted.

Seat Belts ➔ P.30

- Fasten your seat belt and sit upright well back in the seat.
- Check that your passengers are wearing their seat belts correctly.



Fasten your lap belt as low as possible.

Exhaust Gas Hazard ➔ P.68

- Your vehicle emits dangerous exhaust gases that contain carbon monoxide. Do not run the engine in confined spaces where carbon monoxide gas can accumulate.

Child Safety ➔ P.47

- All children 12 and younger should be seated in the rear seat.
- Small children should be properly restrained in a front facing child restraint system.
- Infants must be properly restrained in a rear-facing child restraint system on a rear seat.

Airbags ➔ P.40

- Your vehicle is fitted with airbags to help to protect you and your passengers during a moderate-to-severe collision.

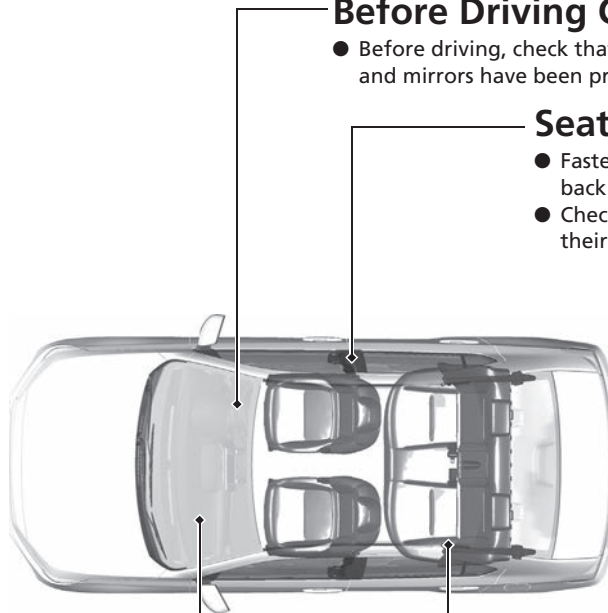

Instrument Panel P.71

Gauges  P.83 / Information Display  P.84 / System Indicators  P.72

Models without keyless access system

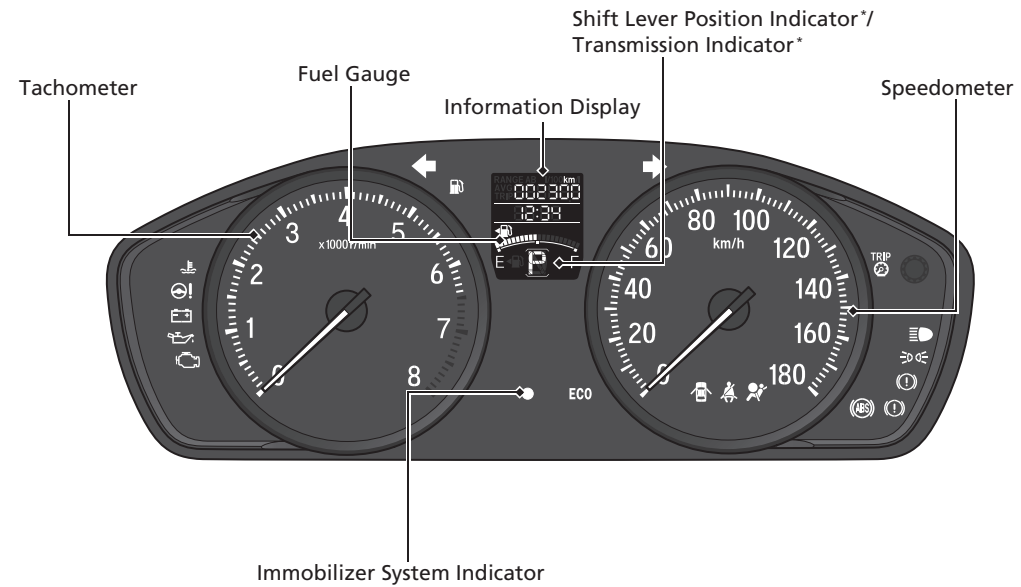

Models with keyless access system

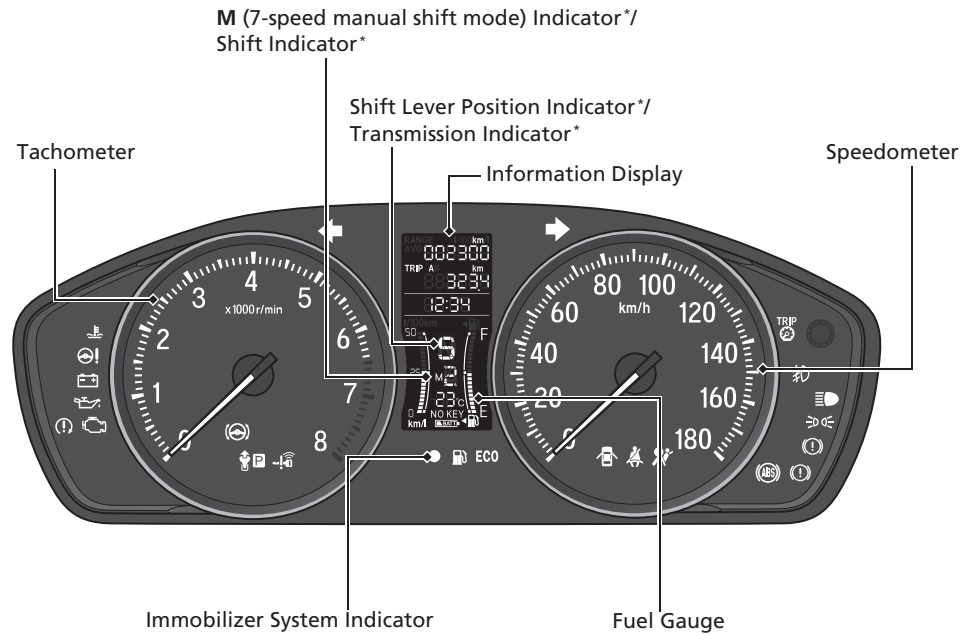

* Not available on all models

Controls ➔ P.89

Clock ➔ P.90

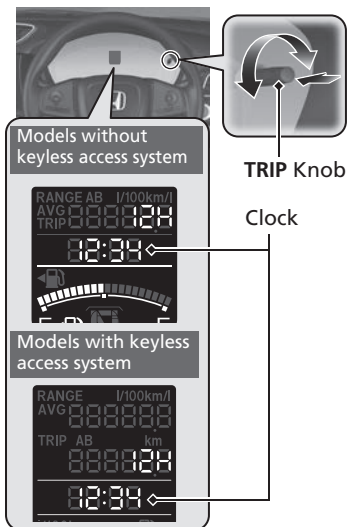

- 1** Press the **TRIP** knob repeatedly until the clock adjustment screen appears on the information display.
- 2** Turn the **TRIP** knob to adjust the minutes.
 - ▶ As you increase or decrease the minutes, the hour moves forward or backward.
- 3** Press the **TRIP** knob to complete clock adjustment.

ENGINE START/STOP Button* ➔ P.112

Press the button to change the vehicle's power mode.



Turn Signals ➔ P.116

Turn Signal Control Lever

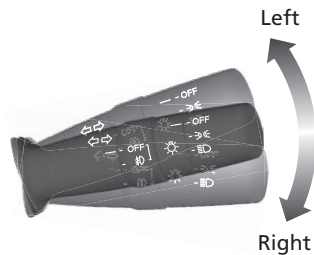

Lights ➔ P.117

Light Control Switches

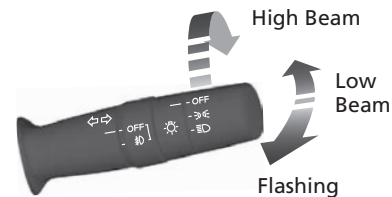

Wipers and Washers

➔ P.120

Wiper/Washer Control Lever

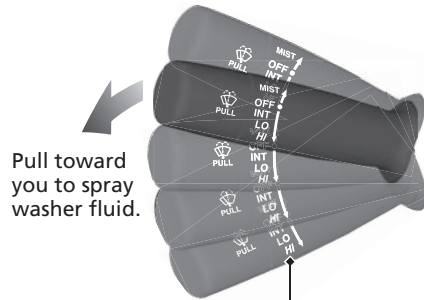

MIST
OFF

INT: Low speed with intermittent
LO: Low speed wipe
HI: High speed wipe

Steering Wheel* ➔ P.124

- To adjust, pull the adjustment lever up, adjust to the desired position, then push the lever back in place.

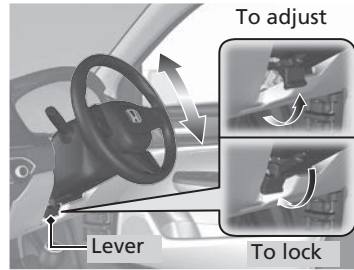

Unlocking the Driver's Door from Inside ➔ P.99

- Pull the driver's door inner handle to unlock and open it at the same time.

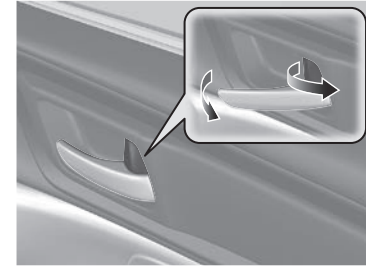

- Unlocking and opening the driver's door from the inner handle unlocks all the other doors.

Boot P. 105

- Pulling the boot opener on the outside of the driver's seat unlocks and opens the boot.
- Press the boot release button* on the boot lid to unlock and open the boot.
- Press the boot release button* on the keyless remote to unlock and open the boot.
- Turn the key in the cylinder* on the boot.

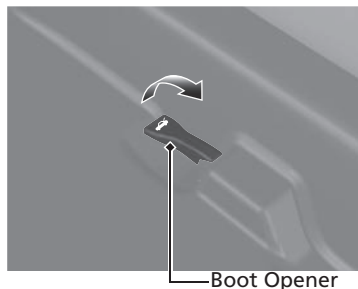

Power Door Mirrors*

 P. 125

- With the ignition switch in ON ^{*1}, move the selector switch to L or R.
- Push the appropriate edge of the adjustment switch to adjust the mirror.
- Push the folding button to fold in and out the door mirrors.

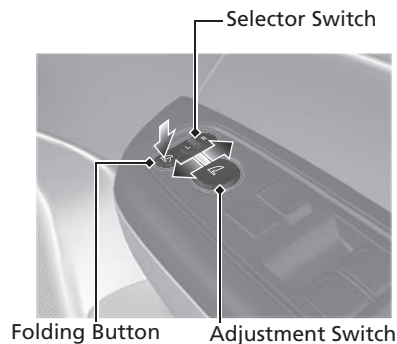



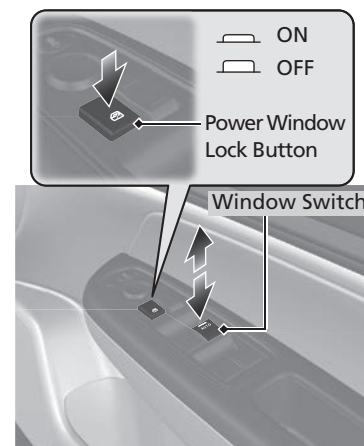

Power Windows P. 109

- With the ignition switch in ON ^{*1}, open and close the power windows.
- If the power window lock button is in the off position, each passenger's window can be opened and closed with its own switch.
- If the power window lock button is in the on position, each passenger's window switch is disabled.





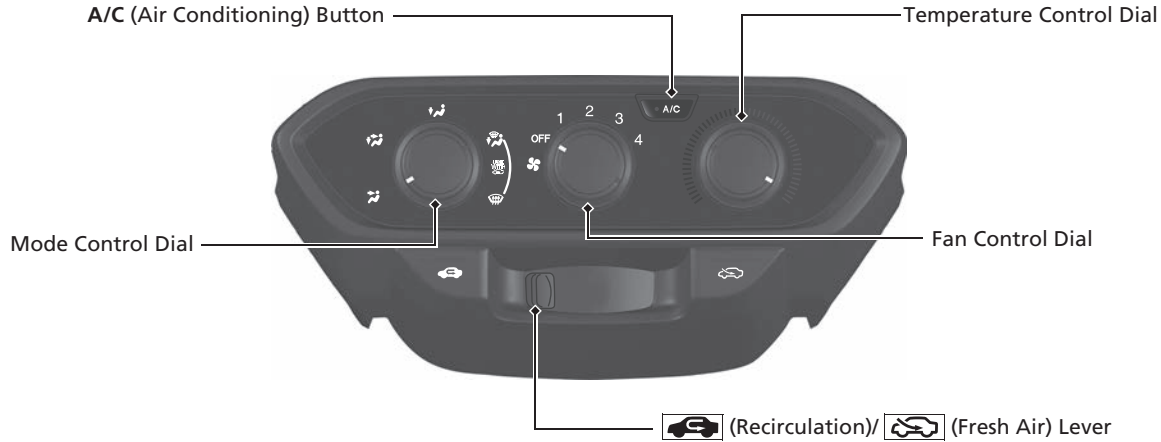

*1 : Models with the keyless access system have an **ENGINE START/STOP** button instead of an ignition switch.

Heating and Cooling System * P.137

- Rotate the fan control dial to adjust the fan speed.
- Turn the mode control dial to  /  /  /  to select the vents air flows from.
- Rotate the temperature control dial to adjust the temperature.
- Rotate the fan control dial to **OFF** to turn the system off.
- Turn the mode control dial to  to defrost the windscreen.



				
Air flows from dashboard vents	Air flows from floor and dashboard vents	Air flows from floor vents	Air flows from floor and windscreen demister vents	Air flows from windscreen demister vents

* Not available on all models

Climate Control System* P.143

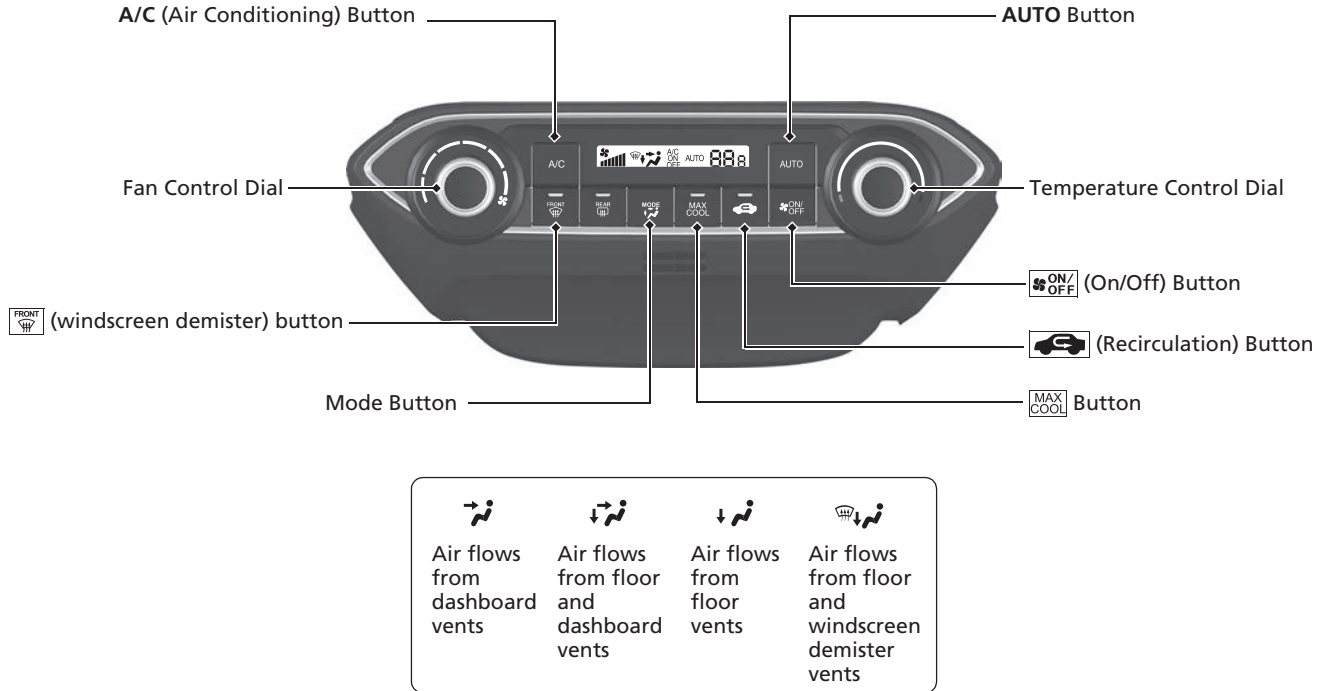

- Press the **AUTO** button to activate the climate control system.
- Press the button to turn the system on or off.
- Press the button to defrost the windshield.

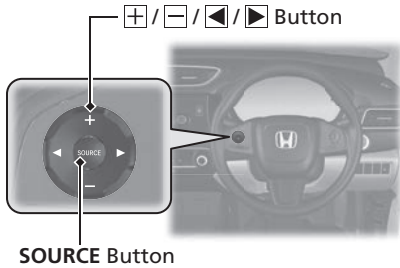

Features P. 147

Audio Remote Controls* P. 152



-  Button
Press to adjust the volume up/down.
- **SOURCE** Button
Press to change the audio mode: FM/AM/USB or iPod/*Bluetooth*® Audio/AUX.
-  Button
Radio: Press to change the preset station.
Press and hold to select the next or previous strong station.
iPod, USB flash drive, or *Bluetooth*® Audio:
Press to skip to the beginning of the next song or return to the beginning of the current song or previous song.
USB flash drive:
Press and hold to change a folder.

Audio System* P. 148

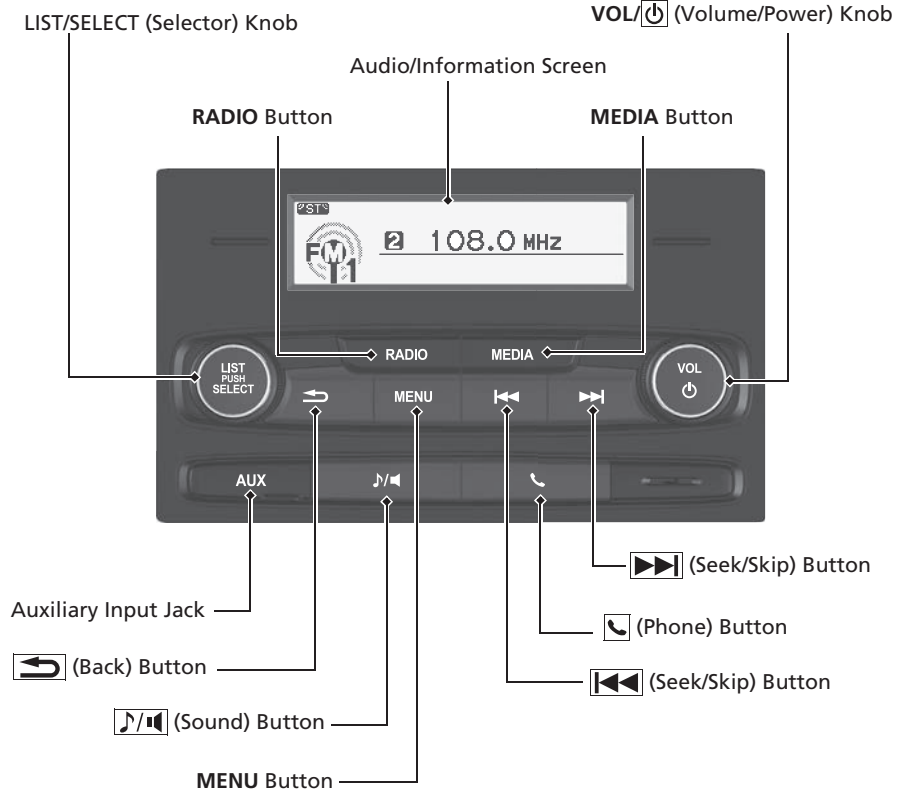

Driving ➔ P.191

Manual Transmission* ➔ P.212

Continuously Variable Transmission* ➔ P.205

- Shift to **P** and depress the brake pedal when starting the engine.

Shifting

Models with
paddle shifters

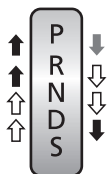

Models without
paddle shifters

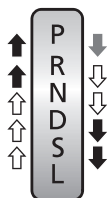

Depress the brake pedal and press the release button to move out of **P**.

Move the shift lever without pressing the release button.

Press the release button to move the shift lever.

Shift Lever



Release Button

- P** **Park**
Used when parking or starting the engine.
- R** **Reverse**
Used when reversing.
- N** **Neutral**
Transmission is not locked.
- D** **Drive**
 - Used for normal driving.
 - On models with paddle shifters, 7-speed manual shift mode can be used temporarily.

- S** **Drive (S)**
 - Used for better acceleration.
 - Used to increase engine braking.
 - Used when going up or down hills.
 - On models with paddle shifters, 7-speed manual shift mode can be used.

- L** **Low***
 - Used to further increase engine braking.
 - Used when going up or down hills.

7-Speed Manual Shift Mode* ➔ P.210

- Allows you to manually shift the transmission up or down without removing your hands from the steering wheel.

When the shift lever is in **S**

- Pulling a paddle shifter changes the mode from continuously variable transmission to 7-speed manual shift mode.
- The **M** indicator and the selected speed number are displayed in the shift indicator.

When the shift lever is in **D**

- Pulling a paddle shifter temporarily changes the mode from continuously variable transmission to 7-speed manual shift mode. The selected speed number is displayed in the shift indicator.

M Indicator

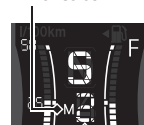

Shift Indicator

Shift Down **-**
Paddle Shifter

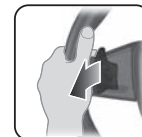

Shift Up **+**
Paddle Shifter



Cruise Control* P. 214

- Cruise control allows you to maintain a set speed without keeping your foot on the accelerator pedal.
- To use cruise control, press the **CRUISE** button, then press the **-/SET** button once you have achieved the desired speed (above 40 km/h).

Refueling P. 224, 225

Petrol models

Fuel recommendation: Unleaded petrol, research octane number 91 or higher

Fuel tank capacity: 35 L

Diesel models

Fuel recommendation: Automotive Diesel Fuel

Fuel tank capacity: 35 L

- 1** Pull the fuel fill door release handle.

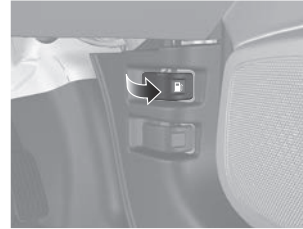

- 2** Turn the fuel fill cap slowly to remove the cap.



- 3** Place the cap in the holder on the fuel fill door.



- 4** After refueling, screw the cap back on until it clicks at least once.



Maintenance ➔ P.229

Under the Bonnet ➔ P.240

- Check engine oil, engine coolant, and window washer fluid. Add when necessary.
- Check brake fluid and clutch fluid*.
- Check the battery condition monthly.

- 1 Pull the bonnet release handle under the driver's side lower outside corner of the dashboard.



- 2 Locate the bonnet latch lever, push it to the side, and then raise the bonnet. Once you have raised the bonnet slightly, you can release the lever.



- 3 When finished, close the bonnet and make sure it is firmly locked in place.

Wiper Blades ➔ P.266

- Replace blades if they leave streaks across the windscreen.



Tyres ➔ P.268

- Inspect tyres and wheels regularly.
- Check tyre pressures regularly.

Lights ➔ P.256

- Inspect all lights regularly.

Handling the Unexpected ↔ P.281

Flat Tyre ↔ P.283

- Park in a safe location and replace the flat tyre with the spare tyre in the boot.



Engine Won't Start ↔ P.290

- If the battery is dead, jump start using a booster battery.

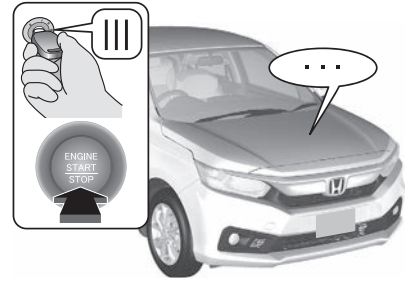

Overheating ↔ P.298

- Park in a safe location. If you do not see steam under the bonnet, open the bonnet, and let the engine cool down.



Indicators Come On/Blink ↔ P.300

↔ P.300

- Identify the indicator and consult the owner's manual.

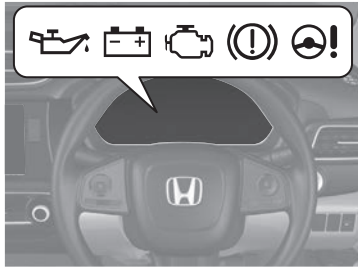

Blown Fuse ↔ P.303

- Check for a blown fuse if an electrical device does not operate.

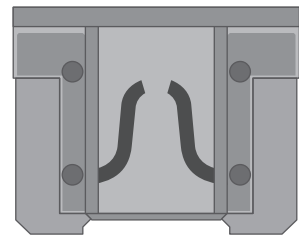

Emergency Towing ↔ P.310

- Call a professional towing service if you need to tow your vehicle.

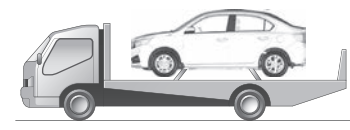

What to Do If

Q

Models without keyless access system

The ignition switch does not turn from **0** to **I**. Why?

Models with keyless access system

The power mode does not change from **VEHICLE OFF (LOCK)** to **ACCESSORY**. Why?

A

• The steering wheel may be locked.

Models without keyless access system

• Try to turn the steering wheel left and right while turning the ignition key.

Models with keyless access system

• Move the steering wheel left and right while pressing the **ENGINE START/STOP** button.



Q

Models without keyless access system

The ignition switch does not turn from **I** to **0** and I cannot remove the key. Why?

Models with keyless access system

The power mode does not change from **ACCESSORY** to **VEHICLE OFF (LOCK)**. Why?

A

Continuously variable transmission models

The shift lever should be moved to **P**.



Q

Why does the brake pedal pulsate slightly when applying the brakes?

A

This can occur when the ABS activates and does not indicate a problem. Apply firm, steady pressure on the brake pedal. Never pump the brake pedal.

➔ Anti-lock Brake System (ABS) ➔ P.219



The rear door cannot be opened from inside the vehicle. Why?



Check if the childproof lock is in the lock position. If so, open the rear door with the outside door handle. To cancel this function, slide the lever up to the unlock position.

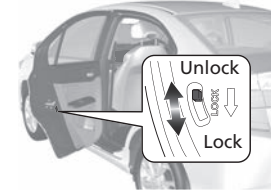

Models with remote transmitter

Why do the doors lock after I unlocked the doors?



If you do not open the doors within 30 seconds, the doors are relocked automatically for security.



Why does the beeper sound when I open the driver's door?



The beeper sounds when:

- The exterior lights are left on.

Models without keyless access system

- The key is left in the ignition switch.

Models with keyless access system

- The power mode is in ACCESSORY.



Why does the beeper sound when I start driving?



The beeper sounds when:

- Driver is not wearing a seat belt.
- The parking brake lever is not fully released.



Why do I hear a screeching sound when I apply the brake pedal?



The brake pads may need to be replaced. Have your vehicle inspected by a dealer.

Safe Driving

You can find many safety recommendations throughout this chapter, and throughout this manual.

For Safe Driving

Important Safety Precautions	26
Your Vehicle's Safety Features.....	28
Safety Checklist	29

Seat Belts

About Your Seat Belts.....	30
Fastening a Seat Belt.....	34
Seat Belt Inspection.....	38
Anchorage Points.....	39

Airbags

Airbag System Components.....	40
Types of Airbags	42

Front Airbags (SRS)	42
Airbag System Indicators.....	45
Airbag Care	46

Child Safety

Protecting Child Passengers	47
Safety of Infants and Small Children....	50
Safety of Larger Children	65

Exhaust Gas Hazard

Carbon Monoxide Gas.....	68
--------------------------	----

Safety Labels

Label Locations	69
-----------------------	----

The following pages explain your vehicle's safety features and how to use them properly. The safety precautions below are ones that we consider to be among the most important.

Important Safety Precautions

■ Always wear your seat belt

A seat belt is your best protection in all types of collisions. Airbags are designed to supplement seat belts, not replace them. So even though your vehicle is equipped with airbags, make sure you and your passengers always wear your seat belts, and wear them properly.

■ Restrain all children

Children aged 12 and under should ride properly restrained in a back seat, not the front seat. Infants and small children should be restrained in a child restraint system. Larger children should use a booster seat and a lap/shoulder seat belt until they can use the belt properly without a booster seat.

■ Be aware of airbag hazards

While airbags can save lives, they can cause serious or fatal injuries to occupants who sit too close to them, or are not properly restrained. Infants, young children, and short adults are at the greatest risk. Be sure to follow all instructions and warnings in this manual.

■ Don't drink and drive

Alcohol and driving don't mix. Even one drink can reduce your ability to respond to changing conditions, and your reaction time gets worse with every additional drink. So don't drink and drive, and don't let your friends drink and drive, either.

⌘ Important Safety Precautions

Some countries prohibit the use of mobile phones other than hands-free devices by the driver while driving.

■ Pay appropriate attention to the task of driving safely

Engaging in mobile phone conversation or other activities that keep you from paying close attention to the road, other vehicles, and pedestrians could lead to a crash. Remember, situations can change quickly, and only you can decide when it is safe to divert some attention away from driving.

■ Control your speed

Excessive speed is a major factor in crash injuries and deaths. Generally, the higher the speed, the greater the risk, but serious injuries can also occur at lower speeds. Never drive faster than is safe for current conditions, regardless of the maximum speed posted.

■ Keep your vehicle in safe condition

Having a tyre blowout or a mechanical failure can be extremely hazardous. To reduce the possibility of such problems, check your tyre pressures and condition frequently, and perform all regularly scheduled maintenance.

■ Do not leave children unattended in the vehicle

Children left unattended in the vehicle may be injured if they activate one or more of the vehicle controls. They may also cause the vehicle to move, resulting in a crash in which the children and/or another person(s) can be injured or killed. Also, depending on the ambient temperature, the temperature of the interior may reach extreme levels, which can result in injury or death. Even if the heating and cooling system[†]/ the climate control system^{*} is on, never leave children in the vehicle unattended as the heating and cooling system[†]/ the climate control system^{*} can shut off at any time.

^{*} Not available on all models

Your Vehicle's Safety Features

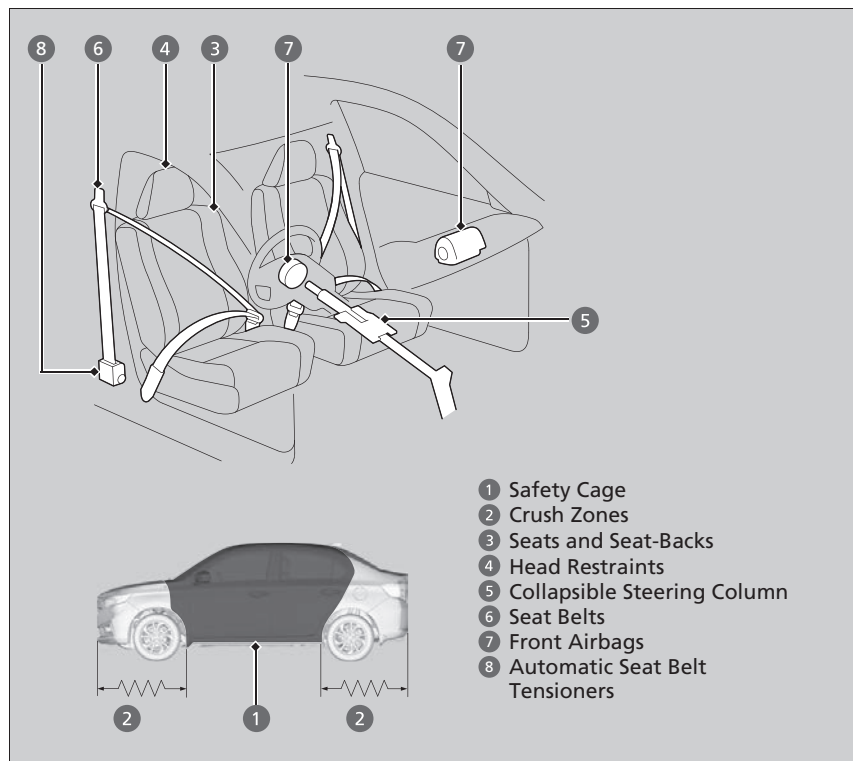

The following checklist will help you take an active role in protecting yourself and your passengers.

► Your Vehicle's Safety Features

Your vehicle is equipped with many features that work together to help to protect you and your passengers during a crash.

Some features do not require any action on your part. These include a strong steel framework that forms a safety cage around the passenger compartment, front and rear crush zones, a collapsible steering column, and tensioners that tighten the front seat belts in a sufficient crash.

However, you and your passengers cannot take full advantage of these features unless you remain seated in the correct position and always wear your seat belts. In fact, some safety features can contribute to injuries if they are not used properly.

Safety Checklist

For the safety of you and your passengers, make a habit of checking these items each time before you drive.

- Adjust your seat to a position suitable for driving. Be sure the front seats are adjusted as far to the rear as possible while allowing the driver to control the vehicle. Sitting too close to a front airbag can result in serious or fatal injury in a crash.
 - **Adjusting the Seats** P. 126
- Always wear your seat belt, and make sure you wear it properly. Confirm that any passengers are properly belted as well.
 - **Fastening a Seat Belt** P. 34
- Protect children by using seat belts or child restraint systems according to a child's age, height and weight.
 - **Child Safety** P. 47

Models with adjustable head restraint

- Adjust head restraints to the proper position. Head restraints are most effective when the centre of the head restraint aligns with the centre of your head. Taller persons should adjust their head restraint to the highest position.
 - **Adjusting the Front Head Restraints*** P. 129

* Not available on all models

➤ Safety Checklist

If the door and boot open indicator is on, a door and/or boot is not completely closed. Close all doors and the boot tightly until the indicator goes off.

➤ **Door and Boot Open Indicator** P. 77

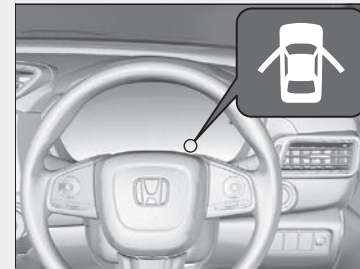

About Your Seat Belts

Seat belts are the single most effective safety device because they keep you connected to the vehicle so that you can take advantage of many built-in safety features. They also help keep you from being thrown against the inside of the vehicle, against any passengers, or out of the vehicle. When worn properly, seat belts also keep your body properly positioned in a crash so that you can take full advantage of the additional protection provided by the airbags.

In addition, seat belts help to protect you in almost every type of crash, including:

- frontal impacts
- side impacts
- rear impacts
- rollovers

About Your Seat Belts

WARNING

Not wearing a seat belt properly increases the chance of serious injury or death in a crash, even though your vehicle has airbags.

Be sure you and your passengers always wear seat belts and wear them properly.

WARNING: Seat belts are designed to bear upon the bony structure of the body, and should be worn low across the front of the pelvis or the pelvis, chest and shoulders, as applicable; wearing the lap section of the belt across the abdominal area must be avoided.

WARNING: Seat belts should be adjusted as firmly as possible, consistent with comfort, to provide the protection for which they have been designed. A slack belt will greatly reduce the protection afforded to the wearer.

WARNING: Belts should not be worn with straps twisted.

WARNING: Each belt assembly must only be used by one occupant; it is dangerous to put a belt around a child being carried on the occupant's lap.

■ Lap/shoulder seat belts

The front and rear outer seating positions are equipped with lap/shoulder seat belts with emergency locking retractors. In normal driving the retractor lets you move freely while keeping some tension on the belt. During a collision or sudden stop the retractor locks to restrain your body.

The seat belt must be properly secured when using a front-facing child restraint system.

📖 **Installing a Child Restraint System with a Lap/Shoulder Seat Belt** P. 61

■ Proper use of seat belts

Follow these guidelines for proper use:

- All occupants should sit upright, well back in the seat, and remain in that position for the duration of the trip. Slouching and leaning reduce the effectiveness of the belt and can increase the chance of serious injury in a crash.
- Never place the shoulder part of a lap/shoulder seat belt under your arm or behind your back. This could cause very serious injuries in a crash.
- Two people should never use the same seat belt. If they do, they could be very seriously injured in a crash.
- Do not put any accessories on the seat belts. Devices intended to improve comfort or reposition the shoulder part of a seat belt can reduce the protective capability and increase the chance of serious injury in a crash.

📖 About Your Seat Belts

If you extend the seat belt too quickly, it will lock in place. If this happens, slightly retract the seat belt, then extend it slowly.

Seat belts cannot completely protect you in every crash. But in most cases, seat belts can reduce your risk of serious injury.

Most countries require you to wear seat belts. Take time to familiarise with the legal requirements of the countries in which you will drive.

Your vehicle's rear centre seat is equipped with the lap seat belt. This seat belt does not come with an emergency locking retractor.

Continued

Seat Belt Reminder



The seat belt system includes an indicator on the instrument panel to remind the driver to fasten a seat belt.

If the ignition switch is turned to ON *1 and a seat belt is not fastened, a beeper will sound and the indicator will blink. After a few seconds, the beeper will stop and the indicator will come on and remain illuminated until a seat belt is fastened.

The beeper will periodically sound and the indicator will blink while the vehicle is moving until the seat belt is fastened.

*1: Models with the keyless access system have an **ENGINE START/STOP** button instead of an ignition switch.

■ Automatic Seat Belt Tensioners

The front seats are equipped with automatic seat belt tensioners to enhance safety.

The tensioners automatically tighten the front seat belts during a moderate-to-severe frontal collision, sometimes even if the collision is not severe enough to inflate the front airbags.

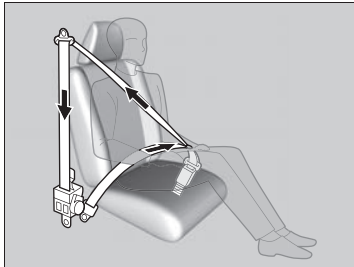

▣ Automatic Seat Belt Tensioners

The seat belt tensioners can only operate once. If a tensioner is activated, the SRS indicator will come on. Have a dealer replace the tensioner and thoroughly inspect the seat belt system as it may not offer protection in a subsequent crash.

Fastening a Seat Belt

Lap/Shoulder Seat Belt

After adjusting a front seat to the proper position, and while sitting upright and well back in the seat:

▶ **Adjusting the Seats** P. 126

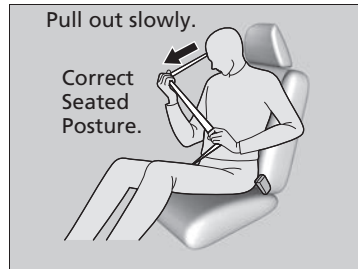

1. Pull the seat belt out slowly.

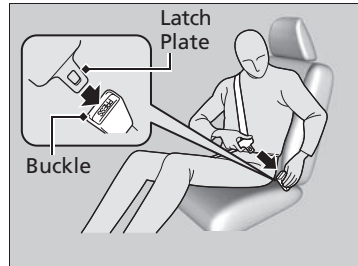

2. Insert the latch plate into the buckle, then tug on the belt to make sure the buckle is secure.

▶ Make sure that the belt is not twisted or caught on anything.

Fastening a Seat Belt

No one should sit in a seat with an inoperative seat belt or one that does not appear to be working correctly. Using a seat belt that is not working properly may not protect the occupant in a crash. Have a dealer check the belt as soon as possible.



3. Position the lap part of the belt as low as possible across your hips, then pull up on the shoulder part of the belt so the lap part fits snugly. This lets your strong pelvic bones take the force of a crash and reduces the chance of internal injuries.
4. If necessary, pull up on the belt again to remove any slack, then check that the belt rests across the centre of your chest and over your shoulder. This spreads the forces of a crash over the strongest bones in your upper body.

Fastening a Seat Belt

⚠ WARNING

Improperly positioning the seat belts can cause serious injury or death in a crash.

Make sure all seat belts are properly positioned before driving.

To release the belt, push the red **PRESS** button and then guide the belt by hand until it has retracted completely.

When exiting the vehicle, be sure the belt is properly stowed so that it will not get caught in the closing door.

Never insert any foreign objects into the buckle or retractor mechanism.

Continued

Lap Belt

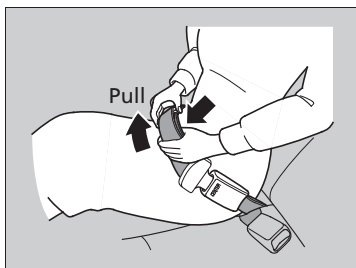
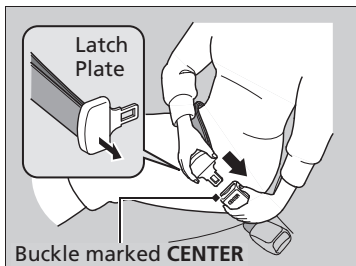
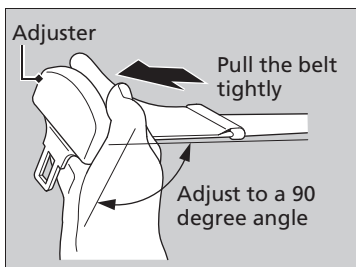

1. Hold the latch plate perpendicular to the tightly-pulled belt. The belt length becomes adjustable.

▶ Slacken the belt before latching.

2. Insert the latch plate into the buckle.

▶ Make sure that the belt is not twisted or caught on anything.

3. Position the belt as low as possible across your hips, then pull up the belt so it fits snugly. This lets your strong pelvic bones take the force of a crash and reduces the chance of internal injuries.

4. If necessary, pull up on the belt again to remove any slack.

Advice for Pregnant Women

If you are pregnant, the best way to protect yourself and your unborn child when driving or riding in a vehicle is to always wear a seat belt and keep the lap part of the belt as low as possible across the hips.

Wear the shoulder belt across the chest avoiding the abdomen.



Wear the lap part of the belt as low as possible across the hips.

Advice for Pregnant Women

Each time you have a checkup, ask your doctor if it is okay for you to drive.

To reduce the risk of injuries to both you and your unborn child that can be caused by an inflating front airbag:

- When driving, sit upright and adjust the seat as far back as possible while allowing full control of the vehicle.
- When sitting in the front passenger's seat, adjust the seat as far back as possible.

Seat Belt Inspection

Regularly check the condition of your seat belts as follows:

- Pull each belt out fully, and look for frays, cuts, burns, and wear.
- Check that the latch plates and buckles work smoothly and the belts retract easily.
 - ▶ If a belt does not retract easily, cleaning the belt may correct the problem. Only use a mild soap and warm water. Do not use bleach or cleaning solvents. Make sure the belt is completely dry before allowing it to retract.

Any belt that is not in good condition or working properly will not provide proper protection and should be replaced as soon as possible.

A belt that has been worn during a crash may not provide the same level of protection in a subsequent crash. Have your seat belts inspected by a dealer after any collision.

Seat Belt Inspection

WARNING

Not checking or maintaining seat belts can result in serious injury or death if the seat belts do not work properly when needed.

Check your seat belts regularly and have any problem corrected as soon as possible.

WARNING: No modifications or additions should be made by the user which will either prevent the seat belt adjusting devices from operating to remove slack, or prevent the seat belt assembly from being adjusted to remove slack.

WARNING: It is essential to replace the entire assembly after it has been worn in a severe impact even if damage to the assembly is not obvious.

WARNING: Care should be taken to avoid contamination of the webbing with polishes, oils and chemicals, and particularly battery acid. Cleaning may safely be carried out using mild soap and water. The belt should be replaced if webbing becomes frayed, contaminated or damaged.

Anchorage Points

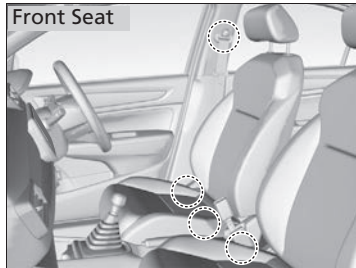

When replacing the seat belts, use the anchorage points shown in the images. The front seat has a lap/shoulder belt.

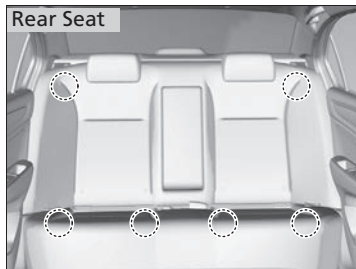

The outside positions of the rear seat have lap/shoulder belts. The centre position has a lap belt.

Airbag System Components

The front airbags are deployed according to the direction and severity of impact. The airbag system includes:

- Two SRS (Supplemental Restraint System) front airbags. The driver's airbag is stored in the centre of the steering wheel; the front passenger's airbag is stored in the dashboard. Both are marked **SRS AIRBAG**.
- An electronic control unit that, when the vehicle is on, continually monitors information about the various impact sensors, seat and buckle sensors, airbag activators, seat belt tensioners, and other vehicle information. During a crash event the unit can record such information.
- Automatic front seat belt tensioners.
- Impact sensors that can detect a moderate-to-severe front impact.
- An indicator on the instrument panel that alerts you to a possible problem with your airbag system or seat belt tensioners.

■ Important facts about your airbags

Airbags can pose serious hazards. To do their job, airbags must inflate with tremendous force. So, while airbags help to save lives, they can cause burns, bruises, and other minor injuries, sometimes even fatal ones if occupants are not wearing their seat belts properly and sitting correctly.

What you should do: Always wear your seat belt properly, and sit upright and as far back from the steering wheel as possible while allowing full control of the vehicle. A front passenger should move their seat as far back from the dashboard as possible.

Remember, however, that no safety system can prevent all injuries or deaths that can occur in a severe crash, even when seat belts are properly worn and the airbags deploy.

Do not place hard or sharp objects between yourself and a front airbag.

Carrying hard or sharp objects on your lap, or driving with a pipe or other sharp object in your mouth, can result in injuries if your front airbag inflates.

Do not attach or place objects on the front airbag covers. Objects on the covers marked **SRS AIRBAG** could interfere with the proper operation of the airbags or be propelled inside the vehicle and hurt someone if the airbags inflate.

▣ Important facts about your airbags

Do not attempt to deactivate your airbags. Together, airbags and seat belts provide the best protection.

When driving, keep hands and arms out of the deployment path of the front airbag by holding each side of the steering wheel. Do not cross an arm over the airbag cover.

Types of Airbags

Your vehicle is equipped with front airbags:

- **Front airbags:** Airbags in front of the driver's and front passenger's seats.

Front Airbags (SRS)

The front SRS airbags inflate in a moderate-to-severe frontal collision to help to protect the head and chest of the driver and/or front passenger.

SRS (Supplemental Restraint System) indicates that the airbags are designed to supplement seat belts, not replace them. Seat belts are the occupant's primary restraint system.

Housing Locations

The front airbags are housed in the centre of the steering wheel for the driver, and in the dashboard for the front passenger. Both airbags are marked **SRS AIRBAG**.

*1: Models with the keyless access system have an **ENGINE START/STOP** button instead of an ignition switch.

Types of Airbags

The airbags can inflate whenever the ignition switch is in ON **II***1.

After an airbag inflates in a crash, you may see a small amount of smoke. This is from the combustion process of the inflator material and is not harmful. People with respiratory problems may experience some temporary discomfort. If this occurs, get out of the vehicle as soon as it is safe to do so.

■ Operation

Front airbags are designed to inflate during moderate-to-severe frontal collisions. When the vehicle decelerates suddenly, the sensors send information to the control unit which signals one or both front airbags to inflate.

A frontal collision can be either head-on or angled between two vehicles, or when a vehicle crashes into a stationary object, such as a concrete wall.

■ How the Front Airbags Work

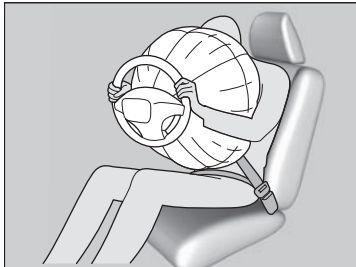

While your seat belt restrains your torso, the front airbag provides supplemental protection for your head and chest.

The front airbags deflate immediately so that they won't interfere with the driver's visibility or the ability to steer or operate other controls.

The total time for inflation and deflation is so fast that most occupants are not aware that the airbags deployed until they see them lying in front of them.

Continued

■ When front airbags should not deploy

Minor frontal crashes: Front airbags were designed to supplement seat belts and help to save lives, not to prevent minor scrapes, or even broken bones that might occur during a less than moderate-to-severe frontal crash.

Side impacts: Front airbags can provide protection when a sudden deceleration causes a driver or front passenger to move towards the front of the vehicle. Front airbags cannot provide any significant protection and are not designed to deploy in such collisions.

Rear impacts: Head restraints and seat belts are your best protection during a rear impact. Front airbags cannot provide any significant protection and are not designed to deploy in such collisions.

Rollovers: Seat belts offer the best protection in a rollover. Because front airbags could provide little if any protection, they are not designed to deploy during a rollover.

■ When front airbags deploy with little or no visible damage

Because the airbag system senses sudden deceleration, a strong impact to the vehicle framework or suspension might cause one or more of the airbags to deploy. Examples include running into a curb, the edge of a hole, or other low fixed object that causes a sudden deceleration in the vehicle chassis. Since the impact is underneath the vehicle, damage may not be readily apparent.

■ When front airbags may not deploy, even though exterior damage appears severe

Since crushable body parts absorb crash energy during an impact, the amount of visible damage does not always indicate proper airbag operation. In fact, some collisions can result in severe damage but no airbag deployment because the airbags would not have been needed or would not have provided protection even if they had deployed.

Airbag System Indicators

If a problem occurs in the airbag system, the SRS indicator will come on.

Supplemental Restraint System (SRS) Indicator



■ When the ignition switch is turned to ON *1

The indicator comes on for a few seconds, then goes off. This tells you the system is working properly.

If the indicator comes on at any other time, or does not come on at all, have the system checked by a dealer as soon as possible. If you don't, your airbags and seat belt tensioners may not work properly when they are needed.

*1: Models with the keyless access system have an **ENGINE START/STOP** button instead of an ignition switch.

Supplemental Restraint System (SRS) Indicator

WARNING

Ignoring the SRS indicator can result in serious injury or death if the airbag systems or tensioners do not work properly.

Have your vehicle checked by a dealer as soon as possible if the SRS indicator alerts you to a possible problem.

Airbag Care

You do not need to, and should not, perform any maintenance on or replace any airbag system components yourself. However, you should have your vehicle inspected by a dealer in the following situations:

■ When the airbags have deployed

If an airbag has inflated, the control unit and other related parts must be replaced. Similarly, once an automatic seat belt tensioner has been activated, it must be replaced.

■ When the vehicle has been in a moderate-to-severe collision

Even if the airbags did not inflate, have your dealer inspect the following: front seat belt tensioners, and each seat belt that was worn during the crash.

✕ Airbag Care

The removal of airbag components from the vehicle is prohibited.

In case of malfunction, or shutdown, or after the airbag inflation/seat belt tensioner operation, ask a qualified personnel for handling.

We recommend against the use of salvaged airbag system components, including the airbag, tensioners, sensors, and control unit.

Child Safety

Protecting Child Passengers

Each year, many children are injured or killed in vehicle crashes because they are either unrestrained or not properly restrained. In fact, vehicle crashes are the number one cause of death of children aged 12 and under.

To reduce the number of child deaths and injuries, infants and children should be properly restrained when they ride in a vehicle.

Children should sit properly restrained in a rear seat. This is because:



- An inflating front airbag can injure or kill a child sitting in the front seat.
- A child in the front seat is more likely to interfere with the driver's ability to safely control the vehicle.
- Statistics show that children of all sizes and ages are safer when they are properly restrained in a rear seat.

Protecting Child Passengers

Front Passenger's Sun Visor

WARNING

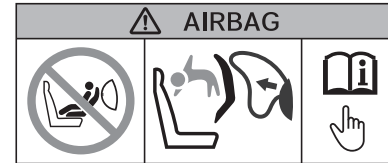

NEVER use a rearward facing child restraint on a seat protected by an **ACTIVE AIRBAG** in front of it, **DEATH** or **SERIOUS INJURY** to the **CHILD** can occur.

WARNING

Children who are unrestrained or improperly restrained can be seriously injured or killed in a crash.

Any child too small for a seat belt should be properly restrained in an approved child restraint system. A larger child should be properly restrained with a seat belt, using a booster seat if necessary.

- Never hold a child on your lap because it is impossible to protect them in the event of a collision.
- Never put a seat belt over yourself and a child. During a crash, the belt would likely press deep into the child and cause serious or fatal injuries.
- Any child who is too small to wear a seat belt must be properly restrained in an approved child restraint system that is properly secured to the vehicle using the seat belt or the child restraint anchorage system.
- Never let two children use the same seat belt. Both children could be very seriously injured in a crash.

► Protecting Child Passengers

In many countries, the law requires all children aged 12 and under, and whose height are shorter than 150 cm be properly restrained in a rear seat.

In many countries, it is required to use an officially approved and suitable child restraint system for transporting a child on any passenger seat. Check your local legal requirement.

Child restraint systems must meet UN Regulation No. 44 or the regulations of the subject countries.

► **Selecting a Child Restraint System** P. 53

- Do not allow children to operate the doors, windows or seat adjustments.
- Do not leave children in the vehicle unattended, especially in hot weather when the inside of the vehicle can get hot enough to kill them. They could also activate vehicle controls causing it to move unexpectedly.

▶▶ Protecting Child Passengers

WARNING: Use the power window lock button to prevent children from opening the windows. Using this feature will prevent children from playing with the windows, which could expose them to hazards or distract the driver.

▶ **Opening/Closing the Power Windows**

P. 109

WARNING: Always take the ignition key with you whenever you leave the vehicle alone or with other occupants.

To remind you of the passenger's front airbag hazard and child safety, your vehicle has the warning label on the passenger's side sun visor.

Please read and follow the instructions on this label.

▶ **Safety Labels** P. 69

Safety of Infants and Small Children

Protecting Infants

An infant must be properly restrained in a rear-facing, reclining child restraint system until the infant reaches the restraint system manufacturer's weight or height limit for the seat, and the infant is at least one year old.

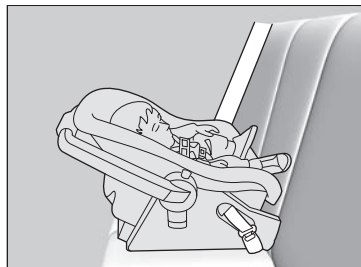

Positioning a rear-facing child restraint system

Child restraint system must be placed and secured in a rear seating position.

- If this occurs, we recommend that you install the child restraint system directly behind the front passenger's seat, move the seat as far forward as needed, and leave it unoccupied.
- Or, you may wish to get a smaller rear-facing child restraint system.
- Make sure that there is no contact between the child restraint system and the seat in front of it.

Protecting Infants

WARNING

Placing a rear-facing child restraint system in the front seat can result in serious injury or death if the passenger's front airbag inflates.

Always place a rear-facing child restraint system in the back seat, not the front.

As required by UN Regulation No. 94:

WARNING

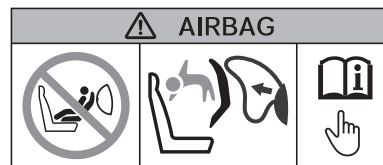

NEVER use a rearward facing child restraint on a seat protected by an ACTIVE AIRBAG in front of it, DEATH or SERIOUS INJURY to the CHILD can occur.

When properly installed, a rear-facing child restraint system may prevent the driver or a front passenger from moving their seat all the way back, or from locking their seat-back in the desired position.

▶▶ Protecting Infants

Many experts recommend use of a rear-facing child restraint system for a child up to two years old, if the child's height and weight are appropriate for a rear-facing child restraint system.

Rear-facing child restraint systems should never be installed in a front-facing position.

Always refer to the child restraint system manufacturer's instructions before installation.

If the passenger's front airbag inflates, it can hit the rear-facing child restraint system with great force, which can dislodge or strike the system, and seriously injure the child.

Continued

Protecting Smaller Children

If a child is at least one year old and has exceeded the weight and height limitations of a rear-facing child restraint system, the child should be properly restrained in a firmly secured front-facing child restraint system until they exceed the weight and height limitations for the front-facing child restraint system.

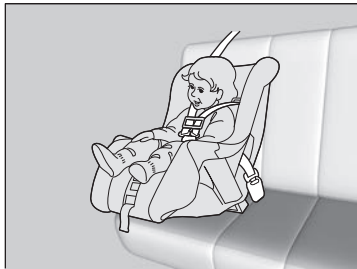

■ Front facing child restraint system placement

We strongly recommend placing a front-facing child restraint system in a rear seating position.

Placing a front-facing child restraint system in the front seat can be hazardous. A rear seat is the safest place for a child.

Protecting Smaller Children

⚠ WARNING

Placing a front-facing child restraint system in the front seat can result in serious injury or death if the front airbag inflates.

If you must place a front-facing child restraint system in front, move the vehicle seat as far back as possible, and properly restrain the child.

Educate yourself about the laws and regulations regarding child restraint system use where you are driving, and follow the child restraint system manufacturer's instructions.

■ Selecting a Child Restraint System

Some child restraint systems are lower anchorage compatible. Some have a rigid-type connector while others have a flexible-type connector. Both are equally easy to use. Some existing and previously owned child restraint systems can only be installed using the seat belt. Whichever type you choose, follow the child restraint system manufacturer's use and care instructions including recommended expiration dates as well as the instructions in this manual. Proper installation is key to maximizing your child's safety.

The flexible type may not be available in your country.

In seating positions and vehicles not equipped with lower anchorages, install a child restraint system using the seat belt and a top tether for added security. This is because all child restraint systems must be secured with the seat belt when the lower anchorage system is not in use. In addition, the child restraint system manufacturer may advise that a seat belt be used to attach an ISO FIX restraint system once a child reaches a specified weight. Please read the child restraint system owner's manual for proper installation instructions.

■ Important consideration when selecting a child restraint system

Make sure the child restraint system meets the following three requirements:

- The child restraint system is the correct type and size for the child.
- The child restraint system is the correct type for the seating position.
- The child restraint system is compliant with safety standard. We recommend the child restraint system with UN Regulation No. 44 or the regulations of the subject countries. Look for the approval mark on the system and the manufacturer's statement of compliance on the box.

Continued

▶▶ Selecting a Child Restraint System

Installation of a lower anchorage-compatible child restraint system is simple.

Lower anchorage-compatible child restraint systems have been developed to simplify the installation process and reduce the likelihood of injuries caused by incorrect installation.

We recommend a rear-facing or a front-facing Honda genuine ISOFIX child restraint system for infants or small children, respectively. Ask your dealer.

The Recommended Child Restraint Systems

Various types of child restraint systems are available. Not all types are suitable for your vehicle. Please refer to the table below to select which category of child restraint system can be used on each seating position.

Lower Anchorage-Compatible Child Restraint Systems

MASS Group	Size class	Fixture	Vehicle ISOFIX positions				Recommended Child Restraint Systems*1
			Front seat	Rear seat			
			Passenger	L-Side	R-Side	Centre	
Carycot	F	ISO/L1	X	X	X	X	
	G	ISO/L2		X	X	X	
Group 0 Up to 10 kg	E	ISO/R1	X	IL	IL	X	Honda genuine ISOFIX
Group 0+ Up to 13 kg	E	ISO/R1	X	IL	IL	X	Honda genuine ISOFIX
	D	ISO/R2		IL	IL	X	Honda genuine ISOFIX
	C	ISO/R3		IL	IL	X	Honda genuine ISOFIX
Group I 9 kg to 18 kg	D	ISO/R2	X	IL	IL	X	
	C	ISO/R3		IL	IL	X	
	B	ISO/F2		IUF	IUF	X	Honda genuine ISOFIX
	B1	ISO/F2X		IUF	IUF	X	Honda genuine ISOFIX
	A	ISO/F3		IUF	IUF	X	Honda genuine ISOFIX
Group II 15 kg to 25 kg			X	X	X	X	
Group III 22 kg to 36 kg			X	X	X	X	

-
- IUF: Suitable for forward facing ISOFIX child restraints system of universal category approved for use in this mass group.
 - IL: Suitable for particular ISOFIX child restraint systems (CRS), including those listed in the corresponding box in the right column of the table. These ISOFIX CRS are those of the 'specific vehicle', 'restricted' or 'semiuniversal' categories.
 - X: Seat position not suitable for children in this mass group.
 - *1: The named Child Restraint Systems (CRS) reflect Honda's recommendations at the date of publication. You should speak to an authorised dealer for up-to-date information on our recommended CRSs. Other CRSs may also be suitable for use. Refer to the CRS manufacturer's list of recommended vehicles for the CRS in question.
-

A size class is specified for some child restraint systems. Make sure to check the size class as indicated on the manufacturer's instructions, package, and labels of the child restraint. The particular child restraints in the table are Honda Genuine Parts. They are available from your dealer.

For a correct installation, please refer to the Child Restraint Instruction Manual.

Child Restraint Systems to be Installed with a Lap/Shoulder Seat Belt

Not all of the various types of child restraint systems are suitable for use in your vehicle. Before you purchase or use a child restraint system, refer to the following table to ensure that the restraint system is appropriate for the vehicle, the seating position, and the child's weight (mass group) and size.

Child Restraint Systems to be Installed with a Lap/Shoulder Seat Belt

Mass group is specified for some child restraint systems. Make sure to check the mass group as indicated in the manufacturer's instructions as well as on the package and labels of the child restraint system.

The particular child restraint systems listed in the table are genuine Honda products. They are available from your dealer.

For correct installation, refer to the instructions manual that came with the child restraint system.

■ Child restraint systems to be installed with a lap/shoulder seat belt

MASS Group		Seat position				Recommended Child Restraint Systems*1
		Front passenger seat	Rear seat			
			L-Side	R-Side	Centre	
Group 0	Up to 10 kg	X	U	U	X	
Group 0+	Up to 13 kg	X	U	U	X	
Group I	9 kg to 18 kg	UF*2	U	U	X	
Group II	15 kg to 25 kg	UF*2	U	U	X	
Group III	22 kg to 36 kg	UF*2	U	U	X	

U: Suitable for 'universal' category restraints approved for use in this mass group.

UF: Suitable for forward facing 'universal' category restraints approved for use in this mass group.

X: Seat position not suitable for children in this mass group.

*1: The named Child Restraint Systems (CRS) reflect Honda's recommendations at the date of publication. You should speak to an authorised dealer for up-to-date information on our recommended CRSs. Other CRSs may also be suitable for use. Refer to the CRS manufacturer's list of recommended vehicles for the CRS in question.

*2: Move the front seat to its slide rail rearmost position.

A size class is specified for some child restraint systems. Make sure to check the size class as indicated on the manufacturer's instructions, package, and labels of the child restraint.

For a correct installation, please refer to the Child Restraint Instruction Manual.

Installing a Lower Anchorage-Compatible Child Restraint System

A lower anchorage-compatible child restraint system can be installed in either of the two outer rear seats. A child restraint system is attached to the lower anchorages with either the rigid or flexible type of connectors.

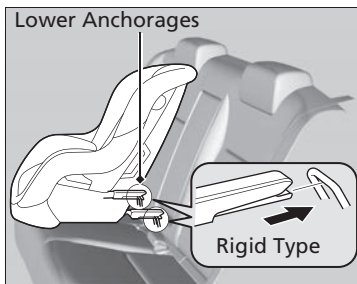
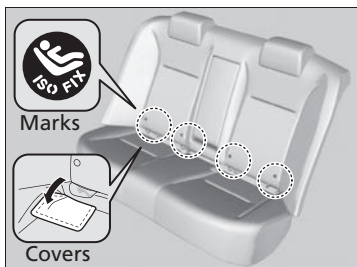

1. Locate the lower anchorages under the marks.
2. Pull out the anchor covers under the marks to expose the lower anchorages.

3. Place the child restraint system on the vehicle seat, then attach the child restraint system to the lower anchorages according to the instructions that came with the child restraint system.
 - When installing the child restraint system, make sure that the lower anchorages are not obstructed by the seat belt or any other object.

Installing a Lower Anchorage-Compatible Child Restraint System

⚠ WARNING

Never attach two child restraint system to the same anchor. In a collision, one anchor may not be strong enough to hold two child restraint system attachments and may break, causing serious injury or death.

Some child restraint systems come with optional guide-cups, which avoid possible damage to the seat surface. Follow the manufacturer's instructions when using the guide-cups, and attach them to the lower anchorages as shown in the image.

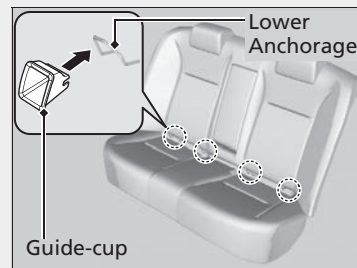

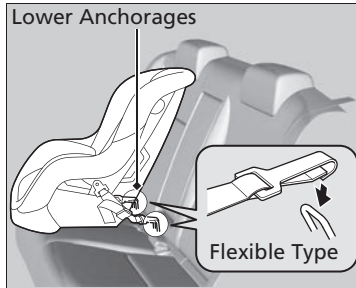

4. Open the tether anchorage cover behind the head restraint.

► Installing a Lower Anchorage-Compatible Child Restraint System

WARNING: Never use a hook that does not come with a Top Tether anchor symbol when securing an installed child restraint system.

For your child's safety, when using a child restraint system installed using the lower anchorage system, make sure that the child restraint system is properly secured to the vehicle. A child restraint system that is not properly secured will not adequately protect a child in a crash and may cause injury to the child or other vehicle occupants.

The flexible type may not be available in your country.

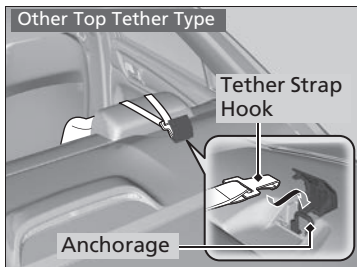
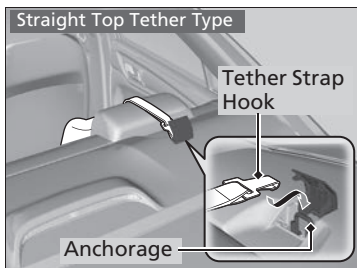

5. Route the tether strap over the top of the head restraint. Make sure the strap is not twisted.
6. Tighten the tether strap as instructed by the child restraint system manufacturer.
7. Make sure the child restraint system is firmly secured by rocking it forward and back, and side to side; little movement should be felt.

■ Installing a Child Restraint System with a Lap/Shoulder Seat Belt

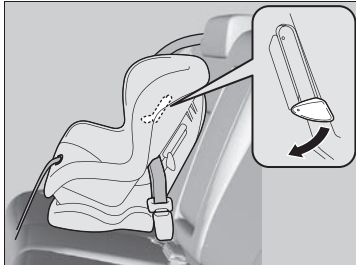

1. Place the child restraint system on the vehicle seat.
2. Route the seat belt through the child restraint system according to the child restraint system manufacturer's instructions, and insert the latch plate into the buckle.
 - Insert the latch plate fully until it clicks.
3. Push down the tab. Route the shoulder part of the belt into the slit at the side of the restraint.
4. Grab the shoulder part of the belt near the buckle, and pull up to remove any slack from the lap part of the belt.
 - When doing this, place your weight on child restraint system and push it into the vehicle seat.
5. Position the belt properly and push up the tab. Make sure the belt is not twisted.
 - When pushing up the tab, pull up the upper shoulder part of the belt to remove any slack from the belt.

▣ Installing a Child Restraint System with a Lap/Shoulder Seat Belt

A child restraint system that is not properly secured will not adequately protect a child in a crash and may cause injury to the child or other vehicle occupants.

Continued

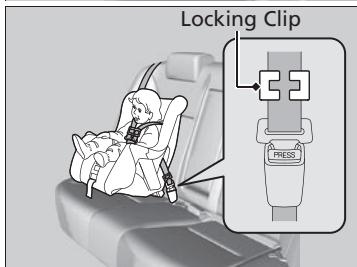

6. Make sure the child restraint system is firmly secured by rocking it forward and back, and side to side; little movement should be felt.
7. Make sure any unused seat belt that a child can reach is buckled.

If your child restraint system does not come with a mechanism that secures the belt, install a locking clip on the seat belt.

After going through the step 1 and 2, pull up the shoulder part of the belt and make sure there is no slack in the lap portion.

3. Tightly grasp the belt near the latch plate. Pinch both parts of the belt together so they do not slip through the latch plate. Unbuckle the seat belt.
4. Install the locking clip as shown in the image. Position the clip as close as possible to the latch plate.
5. Insert the latch plate into the buckle. Go to step 6 and 7.

■ Adding Security with a Tether

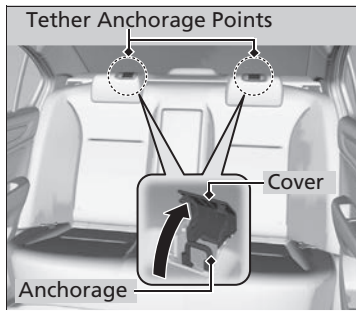

Two tether anchorage points are provided behind rear outer seating position. If you have a child restraint system that comes with a tether but can be installed with a seat belt, the tether may be used for additional security.

1. Locate the appropriate tether anchorage point and lift the cover.
2. Route the tether strap over the top of the head restraint. Make sure the strap is not twisted.

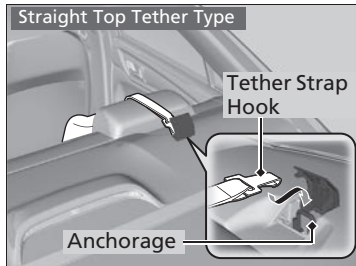

▣ Adding Security with a Tether

WARNING: Child restraint anchorages are designed to withstand only those loads imposed by correctly fitted child restraints. Under no circumstances are they to be used for adult seat belts, harnesses or for attaching other items or equipment to the vehicle.

Always use a tether for forward facing child seats when using the seat belt or lower anchorages.

Continued

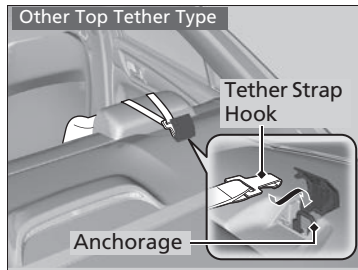

3. Secure the tether strap hook to the anchorage.
4. Tighten the tether strap as instructed by the child restraint system manufacturer.

Safety of Larger Children

■ Protecting Larger Children

The following pages give instructions on how to check proper seat belt fit, what kind of booster seat to use if one is needed, and important precautions for a child who must sit in front.

■ Checking Seat Belt Fit

When a child is too big for a child restraint system, secure the child in a rear seat using the lap/shoulder seat belt. Have the child sit upright and all the way back, then answer the following questions.



■ Checklist

- Do the child's knees bend comfortably over the edge of the seat?
- Does the shoulder belt cross between the child's neck and arm?
- Is the lap part of the seat belt as low as possible, touching the child's thighs?
- Will the child be able to stay seated like this for the whole trip?

If you answer yes to all these questions, the child is ready to wear the lap/shoulder seat belt correctly. If you answer no to any question, the child needs to ride on a booster seat until the seat belt fits properly without a booster seat.

▶ Safety of Larger Children

⚠ WARNING

Allowing a child aged 12 or under to sit in front can result in injury or death if the passenger's front airbag inflates.

If a larger child must ride in front, move the vehicle seat as far to the rear as possible, have the child sit up properly and wear the seat belt properly, using a booster seat if needed.

Continued

Booster Seats



If a lap/shoulder seat belt cannot be used properly, position the child in a booster seat in the rear seat. For the child's safety, check that the child meets the booster seat manufacturer's recommendations.

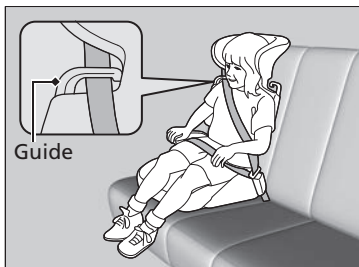

A backrest is available for a specific booster seat. Install the backrest to the booster seat and adjust it to the vehicle seat according to the booster seat manufacturer's instructions. Make sure the seat belt is properly routed through the guide at the shoulder of the backrest and the belt does not touch and cross the child's neck.

Booster Seats

When installing a booster seat, make sure to read the instructions that came with it, and install the seat accordingly.

There are high- and low-type booster seats. Choose a booster seat that allows the child to wear the seat belt correctly.

We recommend a booster seat with a backrest as it is easier to adjust the shoulder belt.

■ Protecting Larger Children - Final Checks

Your vehicle has a rear seat where children can be properly restrained. If you ever have to carry a group of children, and a child must ride in front:

- Make sure you read and fully understand the instructions and safety information in this manual.
- Move the front passenger seat as far back as possible.
- Have the child sit upright and well back in the seat.
- Check that the seat belt is properly positioned so that the child is secure in the seat.

■ Monitoring child passengers

We strongly recommend that you keep an eye on child passengers. Even older, more mature children sometimes need to be reminded to fasten their seat belts and sit up properly.

Exhaust Gas Hazard

Carbon Monoxide Gas

The engine exhaust from this vehicle contains carbon monoxide, a colourless, odourless, and highly toxic gas. As long as you properly maintain your vehicle, carbon monoxide gas will not get into the interior.

■ Have the exhaust system inspected for leaks whenever

- The exhaust system is making an unusual noise.
- The exhaust system may have been damaged.
- The vehicle is raised for an oil change.

When you operate a vehicle with the boot open, airflow can pull exhaust gas into the interior and create a hazardous condition. If you must drive with the boot open, open all the windows and set the heating and cooling system*/the climate control system* as shown below.

1. Select the fresh air mode.
2. Select the  mode.
3. Set the fan speed to high.
4. Set the temperature control to a comfortable setting.

Adjust the heating and cooling system*/the climate control system* in the same manner if you sit in your parked vehicle with the engine running.

☒ Carbon Monoxide Gas

WARNING

Carbon monoxide gas is toxic. Breathing it can cause unconsciousness and even kill you.

Avoid any enclosed areas or activities that expose you to carbon monoxide.

An enclosed area such as a garage can quickly fill up with carbon monoxide gas. Do not run the engine with the garage door closed. Even when the garage door is open, drive out of the garage immediately after starting the engine.

Safety Labels

Label Locations

These labels are in the locations shown. They warn you of potential hazards that can cause serious injury or death. Read these labels carefully.

If a label comes off or becomes hard to read, contact a dealer for a replacement.

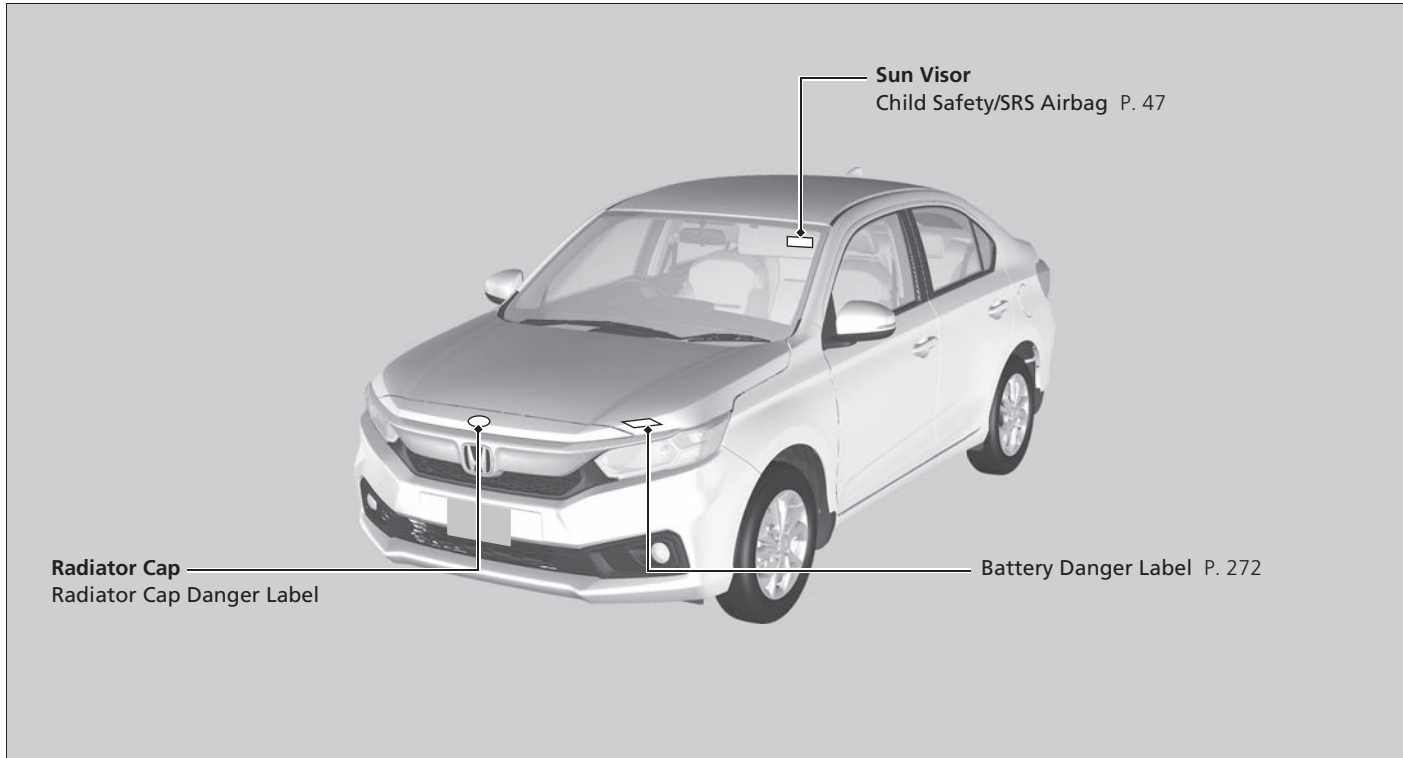

Sun Visor
Child Safety/SRS Airbag P. 47

Radiator Cap
Radiator Cap Danger Label

Battery Danger Label P. 272





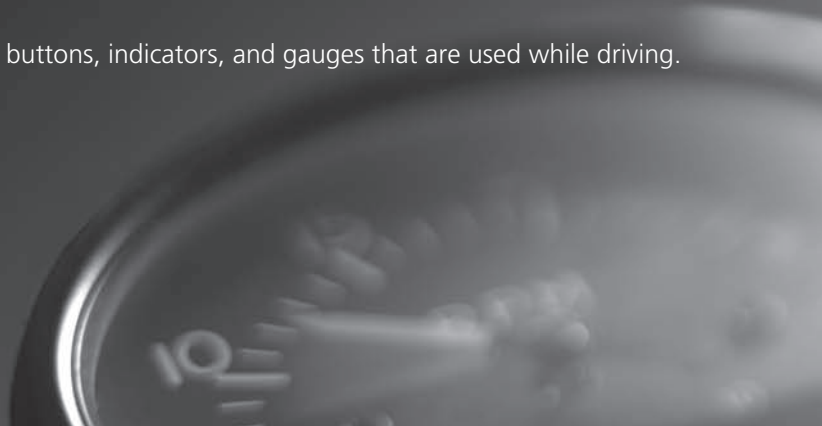





















Instrument Panel

This chapter describes the buttons, indicators, and gauges that are used while driving.





Indicators	72
Information Display Warning and Information Messages.....	82
Gauges and Information Display	
Gauges.....	83
Information Display.....	84

Indicators



 *1	Parking Brake and Brake System Indicator (Red)	→P. 73	 *1	Anti-lock Brake System (ABS) Indicator	→P. 77	 *1	Fog Light Indicator*	→P. 79
 *1	Brake System Indicator (Amber)	→P. 73	 *1	Supplemental Restraint System Indicator	→P. 77	ECO	ECO Indicator	→P. 79
 *1	Low Oil Pressure Indicator	→P. 73	 *1	High Temperature Indicator	→P. 77	 *1	Keyless Access System Indicator*	→P. 79
 *1	Malfunction Indicator Lamp	→P. 74	 *1	Door and Boot Open Indicator	→P. 77		Immobilizer System Indicator	→P. 80
 *1	Charging System Indicator	→P. 74	 *1	Electric Power Steering (EPS) System Indicator	→P. 77	 *1	Starter System Indicator*	→P. 80
D	Shift Lever Position Indicator*	→P. 75	 *1	Glow Plugs Indicator*	→P. 78		Shift to Park Indicator*	→P. 80
M2	M (7-speed manual shift mode) Indicator/Shift Indicator*	→P. 75	 *1	Water in Fuel Indicator*	→P. 78		Rotate Wheel Indicator*	→P. 81
	Transmission Indicator*	→P. 75	PGM-FI *1	PGM-FI Indicator*	→P. 78		CRUISE MAIN Indicator*	→P. 81
	Seat Belt Reminder Indicator	→P. 76		Turn Signal and Hazard Warning Indicators	→P. 79		CRUISE CONTROL Indicator*	→P. 81
	Low Fuel Indicator	→P. 76		High Beam Indicator	→P. 79			
				Lights On Indicator	→P. 79			



*1: When you turn the ignition switch to ON ², these indicators come on to indicate that system checks are being performed. They go off a few seconds later or after the engine has started. If an indicator does not come on or turn off, there may be a malfunction in the corresponding system. To resolve the issue, follow the instructions in the owner's manual.

*2: Models with the keyless access system have an **ENGINE START/STOP** button instead of an ignition switch.



Indicator	Name	On/Blinking	Explanation
 (Red)	Parking Brake and Brake System Indicator (Red)	<ul style="list-style-type: none"> • Comes on when the parking brake is applied and goes off when it is released. • Comes on when the brake fluid level is low. • Comes on if there is a problem with the brake system. • The beeper sounds and the indicator comes on if you drive with the parking brake not fully released. 	<ul style="list-style-type: none"> • Comes on while driving - Make sure the parking brake is released. Check the brake fluid level. <ul style="list-style-type: none"> ➤ What to do when the indicator comes on while driving P. 301 • Comes on along with the ABS indicator - Have the vehicle checked by a dealer. <ul style="list-style-type: none"> ➤ If the Brake System Indicator (Red) Comes On P. 301
 (Amber)	Brake System Indicator (Amber)	<ul style="list-style-type: none"> • Comes on if there is a problem with a system related to braking other than the conventional brake system. 	<ul style="list-style-type: none"> • Stays on constantly - Have the vehicle checked by a dealer.
	Low Oil Pressure Indicator	<ul style="list-style-type: none"> • Comes on when the engine oil pressure is low. 	<ul style="list-style-type: none"> • Comes on while driving - Immediately stop in a safe place. <ul style="list-style-type: none"> ➤ If the Low Oil Pressure Indicator Comes On P. 300 Diesel models ➤ Starting the Engine P. 197

Instrument Panel









Indicator	Name	On/Blinking	Explanation
	Malfunction Indicator Lamp	<ul style="list-style-type: none"> • Comes on if there is a problem with the emissions control system. • Blinks when a misfire in the engine's cylinders is detected. 	<ul style="list-style-type: none"> • Comes on while driving - Have the vehicle checked by a dealer. • Blinks while driving - Stop in a safe place where there are no flammable objects. Stop the engine for 10 minutes or more, and wait for it to cool down. Then, take the vehicle to a dealer. <ul style="list-style-type: none"> ➤ If the Malfunction Indicator Lamp Comes On or Blinks P. 301
	Charging System Indicator	<ul style="list-style-type: none"> • Comes on when the battery is not charging. 	<ul style="list-style-type: none"> • Comes on while driving - Turn off the air conditioning system to reduce electricity consumption. <ul style="list-style-type: none"> ➤ If the Charging System Indicator Comes On P. 300





Indicator	Name	On/Blinking	Explanation
	Shift Lever Position Indicator*	<ul style="list-style-type: none"> Indicates the current shift lever position. 	<p>► Shifting P. 205, 208</p>
	M (7-speed manual shift mode) Indicator/Shift Indicator*	<ul style="list-style-type: none"> Comes on when 7-speed manual shift mode is applied. 	<p>► 7-Speed Manual Shift Mode P. 210</p>
	Transmission Indicator*	<ul style="list-style-type: none"> Blinks if the transmission system has a problem. 	<ul style="list-style-type: none"> Blinks while driving - Avoid sudden starts and acceleration and have your vehicle checked by a dealer immediately.

* Not available on all models







Indicator	Name	On/Blinking	Explanation
	Seat Belt Reminder Indicator	<ul style="list-style-type: none"> Blinks and the beeper sounds for a few seconds if you are not wearing a seat belt when you turn the ignition switch to ON II*1, then the indicator comes on. Blinks while driving if you have not fastened a seat belt. The beeper sounds and the indicator blinks at regular intervals. 	<ul style="list-style-type: none"> The beeper stops and the indicator goes off when you fasten your seat belt. Stays on after you have fastened the seat belt - A detection error may have occurred in the sensor. Have the vehicle checked by a dealer. ➤ Seat Belt Reminder P. 32
	Low Fuel Indicator	<ul style="list-style-type: none"> Comes on when the fuel reserve is running low (approximately 4.8 Litres left). Blinks if there is a problem with the fuel gauge. <div style="background-color: #cccccc; padding: 2px;">Diesel models</div> <ul style="list-style-type: none"> The fuel gauge dot disappeared. 	<ul style="list-style-type: none"> Comes on - Refuel your vehicle as soon as possible. Blinks - Have the vehicle checked by a dealer. <ul style="list-style-type: none"> Even if you depress the accelerator pedal, the engine speed (RPM) will not increase. Refuel your vehicle as soon as possible then restart the engine. The vehicle speed limit will be released when refueling 10.0 Litres or more. ➤ Refueling P. 224

* 1: Models with the keyless access system have an **ENGINE START/STOP** button instead of an ignition switch.

Indicator	Name	On/Blinking	Explanation
	Anti-lock Brake System (ABS) Indicator	<ul style="list-style-type: none"> Comes on if there is a problem with the ABS. 	<ul style="list-style-type: none"> Stays on constantly - Have the vehicle checked by a dealer. With this indicator on, your vehicle still has normal braking ability but no anti-lock function.  Anti-lock Brake System (ABS) P. 219
	Supplemental Restraint System Indicator	<ul style="list-style-type: none"> Comes on if a problem with any of the following is detected: <ul style="list-style-type: none"> Supplemental restraint system Seat belt tensioner 	<ul style="list-style-type: none"> Stays on constantly - Have the vehicle checked by a dealer.
	High Temperature Indicator	<ul style="list-style-type: none"> Blinks when the engine coolant temperature goes up, and stays on if the temperature continues to rise. 	<ul style="list-style-type: none"> Blinks while driving - Drive slowly to prevent overheating. Stays on while driving - Immediately stop in a safe place and allow the engine to cool.  Overheating P. 298
	Door and Boot Open Indicator	<ul style="list-style-type: none"> Comes on if any door or the boot is not completely closed. Comes on if any door or the boot is opened while driving. The beeper sounds. 	<ul style="list-style-type: none"> Goes off when all doors and the boot are closed.
	Electric Power Steering (EPS) System Indicator	<ul style="list-style-type: none"> Comes on if there is a problem with the EPS system. 	<ul style="list-style-type: none"> Stays on constantly - Have the vehicle checked by a dealer.  If the Electric Power Steering (EPS) System Indicator Comes On P. 302





Indicator	Name	On/Blinking	Explanation
	Glow Plugs Indicator*	<ul style="list-style-type: none"> Comes on for a while when you turn the ignition switch to ON *1 under the extremely low engine coolant temperature condition, then goes off. 	<ul style="list-style-type: none"> Stays on - The engine is cold. Do not start the engine until the indicator goes off. <ul style="list-style-type: none"> ➤ Starting the Engine P. 197 If you still find it hard to start the engine, have your vehicle inspected by a dealer.
	Water in Fuel Indicator*	<ul style="list-style-type: none"> Comes on when water has accumulated in the fuel system. Comes on if you have parked your vehicle for an extended period. 	<ul style="list-style-type: none"> Have a dealer drain off the water from the system as soon as possible. Accumulated water may cause damage to the fuel system. Have your vehicle checked by a dealer.
	PGM-FI Indicator*	<ul style="list-style-type: none"> Comes on while driving if there is a problem with the engine control system. Comes on if you do not use the proper fuel for the climate or regional conditions. 	<ul style="list-style-type: none"> ➤ If the PGM-FI Indicator Comes On P. 302 Use of inadequate fuel may reduce engine power. <ul style="list-style-type: none"> ➤ Fuel recommendation P. 225





*1: Models with the keyless access system have an **ENGINE START/STOP** button instead of an ignition switch.

Indicator	Name	On/Blinking	Explanation
	Turn Signal and Hazard Warning Indicators	<ul style="list-style-type: none"> Blinks when you operate the turn signal lever. Blink along with all turn signals if you press the hazard warning button. 	<ul style="list-style-type: none"> Does not blink or blinks rapidly - A turn signal light bulb has blown. Change the bulb immediately.  Replacing Light Bulbs P. 259, 261, 262
	High-Beam Indicator	<ul style="list-style-type: none"> Comes on when the high beam headlights are on. 	—
	Lights On Indicator	<ul style="list-style-type: none"> Comes on whenever the light switch is on. 	<ul style="list-style-type: none"> If you remove the key from the ignition switch*, or set the power mode* to VEHICLE OFF while the exterior lights are on, a chime sounds when the driver's door is opened.
	Fog Light Indicator*	<ul style="list-style-type: none"> Comes on when the fog lights are on. 	—
ECO	ECO Indicator	<ul style="list-style-type: none"> Comes on while the engine is operating in its most economical range. 	—
	Keyless Access System Indicator*	<ul style="list-style-type: none"> Comes on as soon as a problem is detected in the keyless access system or keyless starting system. 	<ul style="list-style-type: none"> Stays on constantly - Have your vehicle checked by a dealer.

Instrument Panel

* Not available on all models

Indicator	Name	On/Blinking	Explanation
<div style="border: 1px solid black; padding: 5px; margin-bottom: 5px;">Models without keyless access system</div>  <p style="text-align: center;">Indicator</p> <div style="border: 1px solid black; padding: 5px; margin-bottom: 5px;">Models with keyless access system</div>  <p style="text-align: center;">Indicator</p>	Immobilizer System Indicator	<ul style="list-style-type: none"> Blinks if the immobilizer system cannot recognise the key information. 	<ul style="list-style-type: none"> Blinks- <ul style="list-style-type: none"> Models without keyless access system You cannot start the engine. Turn the ignition switch to LOCK [0], pull the key out, and then insert the key and turn it to ON [II] again. Models with keyless access system You cannot start the engine. Set the power mode to VEHICLE OFF, then select the ON mode again. Repeatedly blinks - The system may be malfunctioning. Have the vehicle checked by a dealer. Do not attempt to alter this system or add other devices to it. Electrical problems can occur.
	Starter System Indicator*	<ul style="list-style-type: none"> Comes on if the starting system has a problem. 	<ul style="list-style-type: none"> As a temporary measure, press and hold the ENGINE START/STOP button for up to 15 seconds while pressing the brake pedal and clutch pedal (manual transmission only), and manually start the engine. Have your vehicle checked by a dealer.
	Shift to Park Indicator*	<ul style="list-style-type: none"> Blinks when you press the ENGINE START/STOP button to turn the engine off without the shift lever in [P]. 	<ul style="list-style-type: none"> Press the ENGINE START/STOP button twice after moving the shift lever to [P].

Indicator	Name	On/Blinking	Explanation
	Rotate Wheel Indicator*	<ul style="list-style-type: none"> Blinks when the steering wheel is locked. 	<ul style="list-style-type: none"> Move the steering wheel left and right while pressing the ENGINE START/STOP button.
	CRUISE MAIN Indicator*	<ul style="list-style-type: none"> Comes on when you press the CRUISE button. 	<ul style="list-style-type: none">  Cruise Control* P. 214
	CRUISE CONTROL Indicator*	<ul style="list-style-type: none"> Comes on when you have set a speed for cruise control. 	<ul style="list-style-type: none">  Cruise Control* P. 214



Instrument Panel

* Not available on all models

Models with keyless access system

Information Display Warning and Information Messages

The following messages appear only on the information display.

Message	Condition	Explanation
	<ul style="list-style-type: none"> Appears when you close the door with the power mode in ON without the keyless remote inside the vehicle. 	<ul style="list-style-type: none"> Disappears when you bring the keyless remote back inside the vehicle and close the door.
	<ul style="list-style-type: none"> Appears when the keyless remote's battery becomes weak. 	<ul style="list-style-type: none"> Replace the battery as soon as possible. <ul style="list-style-type: none"> ➤ Replacing the Button Battery P. 274

Gauges and Information Display

Gauges

Gauges include the speedometer, tachometer, and related indicators. They are displayed when the ignition switch is in ON *1.

■ Speedometer

Displays your driving speed in km/h.

■ Tachometer

Shows the number of engine revolutions per minute.

*1 : Models with the keyless access system have an **ENGINE START/STOP** button instead of an ignition switch.

Information Display

The information display shows the odometer, trip meter, and other gauges.

Switching the Display

Press the **TRIP** knob to change the display.

Each time you press the **TRIP** knob, the information display changes as follows:

► Switching the Display

► Adjusting the Clock P. 90

Models without keyless access system

TRIP Knob

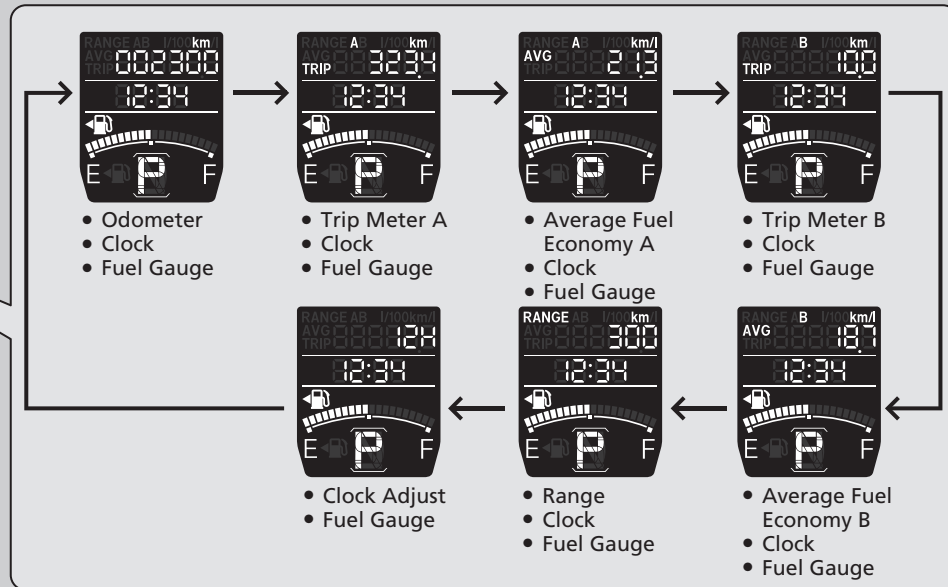

Models with keyless access system

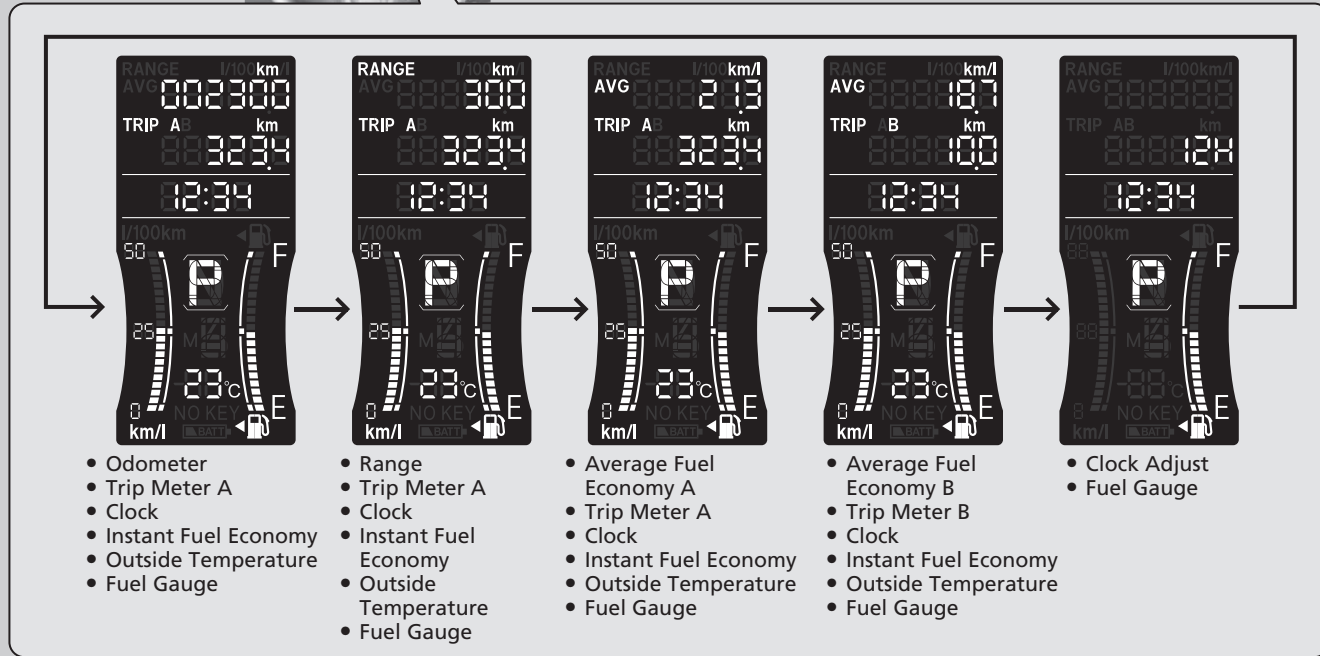
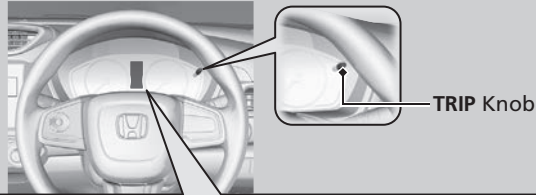

■ Fuel Gauge

Displays the amount of fuel left in the fuel tank.

■ Odometer

Shows the total number of kilometres that your vehicle has accumulated.

■ Trip Meter

Shows the total number of kilometres driven since the last reset. Meters A and B can be used to measure 2 separate trips.

■ Resetting a trip meter

To reset a trip meter, display it, then press and hold the **TRIP** knob. The trip meter is reset to **0.0**.

■ Instant Fuel Economy*

Shows the instant fuel economy as a bar graph in km/l.

⌘ Fuel Gauge

NOTICE

You should refuel when the reading approaches **E**. Running out of fuel can cause the engine to misfire, damaging the catalytic converter.

The actual amount of remaining fuel may differ from the fuel gauge reading.

⌘ Trip Meter

Switch between trip meter A and trip meter B by pressing the **TRIP** knob.

■ Average Fuel Economy

Shows the estimated average fuel economy of each trip meter in km/l. The display is updated at set intervals. When a trip meter is reset, the average fuel economy is also reset.

■ Range

Shows the estimated distance you can travel on the remaining fuel. This estimated distance is based on the vehicle's current fuel economy.

■ Outside Temperature*

Shows the outside temperature in Celsius.

If the outside temperature has been below 3°C at the time you set the power mode to ON, the outside temperature indicator blinks for 10 seconds.

■ Adjusting the outside temperature display

Adjust the temperature reading up to $\pm 3^{\circ}\text{C}$ if the temperature reading seems incorrect.

1. Set the power mode to ON.
2. Press and hold the **TRIP** knob for 10 seconds or more.
 - The following sequence appears for 1 second each: 0, 1, 2, 3, -3, -2, -1, 0
3. When it reaches the desired value, release the **TRIP** knob.
 - The new outside temperature is now entered.

▣ Outside Temperature*

The temperature sensor is in the front bumper. Road heat and exhaust from another vehicle can affect the temperature reading when your vehicle speed is less than 30 km/h.

It may take several minutes for the display to be updated after the temperature reading has stabilised.

Controls

This chapter explains how to operate the various controls necessary for driving.

Clock	90
Locking and Unlocking the Doors	
Key Types and Functions	91
Low Keyless Remote Signal Strength*	93
Locking/Unlocking the Doors from the Outside	94
Locking/Unlocking the Doors from the Inside	99
Childproof Door Locks	100
Auto Door Locking/Unlocking*	101
Customizing the Auto Door Locking/ Unlocking Setting*	102
Opening and Closing the Boot	105

Security System	
Immobilizer System	108
Opening and Closing the Windows	109
Operating the Switches Around the Steering Wheel	
Ignition Switch	111
ENGINE START/STOP Button.....	112
Ignition Switch and Power Mode Comparison	115
Turn Signals	116
Light Switches.....	117
Fog Lights*	118
Headlight Adjuster	119
Wipers and Washers	120

Rear Demister Button*	121
Brightness Control	122
Adjusting the Steering Wheel*.....	124
Adjusting the Mirrors	
Interior Rearview Mirror	125
Power Door Mirrors*	125
Adjusting the Seats	126
Interior Lights/Interior Convenience Items	
Interior Lights	132
Interior Convenience Items	133
Heating and Cooling System*	137
Climate Control System*	143

* Not available on all models

Clock

Adjusting the Clock

You can adjust the time in the clock display, with the ignition switch in ON *1.

Adjusting the Time

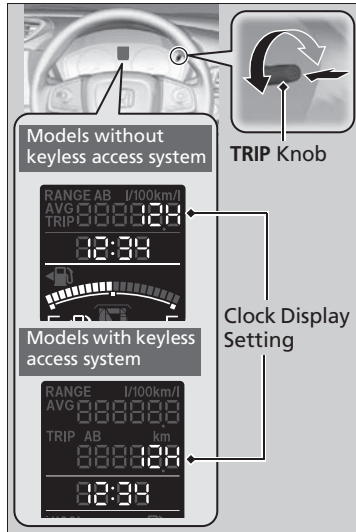

1. Turn the ignition switch to ON *1.
2. Press the **TRIP** knob repeatedly until the clock adjustment screen appears on the information display.
3. Turn the **TRIP** knob to adjust the minutes.
 - ▶ As you increase or decrease the minutes, the hour moves forward or backward.
4. Press the **TRIP** knob to complete clock adjustment.

Adjusting the Clock

You can also switch the clock display to show the 12 hour clock, 24 hour clock, or turn it off by pressing and holding the knob while the clock adjustment screen is shown.

*1: Models with the keyless access system have an **ENGINE START/STOP** button instead of an ignition switch.

Locking and Unlocking the Doors

Key Types and Functions

This vehicle comes with the following keys:

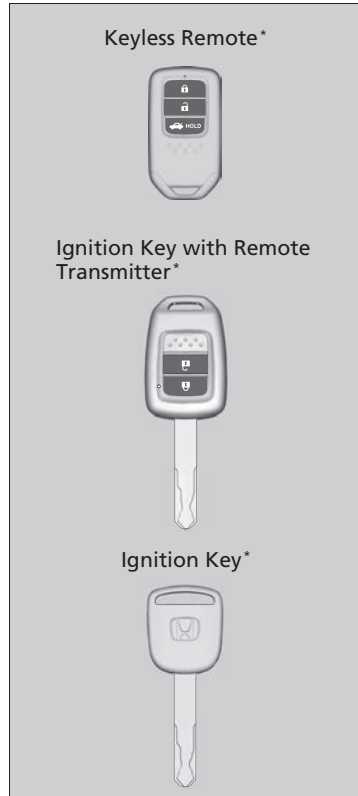

Use the key to start and stop the engine, and to lock and unlock all the doors and to open the boot. You can also use the remote transmitter* or keyless access system* to lock and unlock all the doors and to open the boot*.

* Not available on all models

Key Types and Functions

All the keys have an immobilizer system. The immobilizer system helps to protect against vehicle theft.

Immobilizer System P. 108

Follow the advice below to prevent damage to the keys:

- Do not leave the keys in direct sunlight, or in locations with high temperature or high humidity.
- Do not drop the keys or set heavy objects on them.
- Keep the keys away from liquids, dust and sand.
- Do not take the keys apart except for replacing the battery.

If the circuits in the keys are damaged, the engine may not start, and the remote transmitter*, keyless access system* may not work.

If the keys do not work properly, have them inspected by a dealer.

Continued

■ Built-in Key*

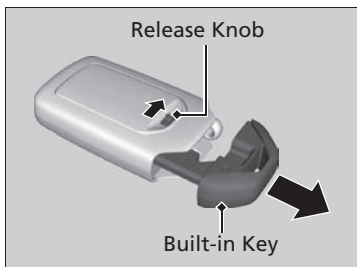

The built-in key can be used to lock/unlock the doors when the keyless remote battery becomes weak and the power door lock/unlock operation is disabled.

To remove the built-in key, slide the release knob and then pull out the key. To reinstall the built-in key, push the built-in key into the keyless remote until it clicks.

■ Key Number Tag

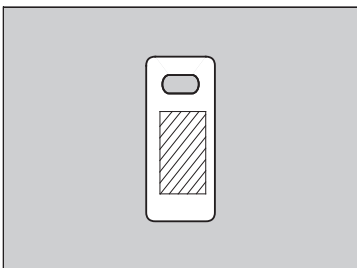

Contains a number that you will need if you purchase a replacement key.

☒ Key Number Tag

Keep the key number tag separate from the key in a safe place outside of your vehicle. If you wish to purchase an additional key, contact a dealer.

If you lose your key and you cannot start the engine, contact a dealer.

Low Keyless Remote Signal Strength *

The vehicle transmits radio waves to locate the keyless remote when locking/unlocking the doors, opening the boot, or to start the engine.

In the following cases, locking/unlocking the doors and boot, or starting the engine may be inhibited or operation may be unstable:

- Strong radio waves are being transmitted by nearby equipment.
- You are carrying the keyless remote together with telecommunications equipment, laptop computers, mobile phones, or wireless devices.
- A metallic object is touching or covering the keyless remote.

▶▶ Low Keyless Remote Signal Strength *

Communication between the keyless remote and the vehicle consumes the keyless remote's battery. Battery life is about two years, but this varies depending on regularity of use.

The battery is consumed whenever the keyless remote is receiving strong radio waves. Avoid placing it near electrical appliances such as televisions and personal computers.

* Not available on all models

Locking/Unlocking the Doors from the Outside

■ Using the Keyless Access System *

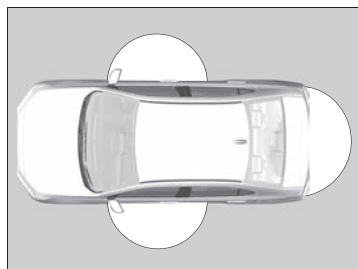

When you carry the keyless remote, you can lock/unlock the doors and boot. You can lock/unlock the doors and the boot within a radius of about 80 cm of the outside front door handle. You can open the boot within about 80 cm radius from the boot release button.

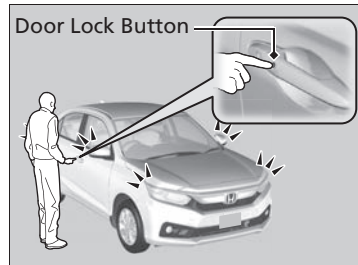

■ Locking the doors and boot

Press the door lock button on the front door.

- ▶ Some exterior lights flash; the beeper sounds; all the doors and boot lock.

⌘ Locking/Unlocking the Doors from the Outside

If the interior light switch is in the door activated position, the interior light comes on when you unlock the doors.

No doors opened: The light fades out after 30 seconds.

Doors relocked: The light goes off immediately.

➤ **Interior Lights** P. 132

⌘ Using the Keyless Access System *

If you do not open a door within 30 seconds of unlocking the vehicle with the keyless access system, the doors will automatically relock.

You can lock or unlock doors and boot using the keyless access system only when the power mode is in VEHICLE OFF.

- Do not leave the keyless remote in the vehicle when you get out. Carry it with you.
- Even if you are not carrying the keyless remote, you can lock/unlock the doors and the boot while someone else with the remote is within range.
- The door may be unlocked if the door handle is covered with water in heavy rain or in a car wash if the keyless remote is within range.
- If you grip a front door handle wearing gloves, the door sensor may be slow to respond or may not respond by unlocking the doors.

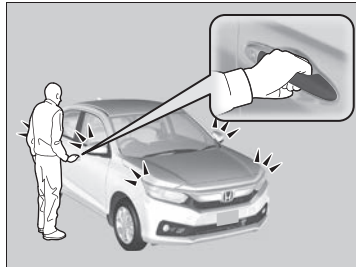

■ Unlocking the doors and boot

Grab the front door handle:

- ▶ All doors and boot unlock.
- ▶ Some exterior lights flash twice and the beeper sounds twice.

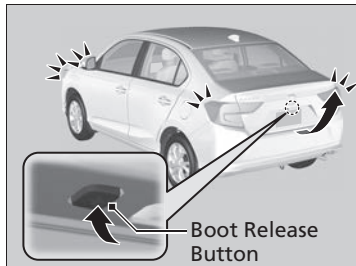

Push up the boot release button:

- ▶ The boot unlocks and opens.
 - ▶ Some exterior lights flash twice and the beeper sounds once.
- ☒ **Using the Boot Release Button*** P. 107

☒ Using the Keyless Access System*

- After locking the door, you have up to 2 seconds during which you can pull the door handle to confirm whether the door is locked.
- If you need to unlock the door immediately after locking it, wait at least 2 seconds before gripping the handle, otherwise the door will not unlock.
- The door may not open if you pull it immediately after gripping the door handle. Grip the handle again and confirm that the door is unlocked before pulling the handle.
- Even within the 80 cm radius, you may not be able to lock/unlock the doors and the boot with the keyless remote if it is above or below the outside handle.
- The keyless remote may not operate if it is too close to the door and door glass.

* Not available on all models

Continued

■ Using the Remote Transmitter*

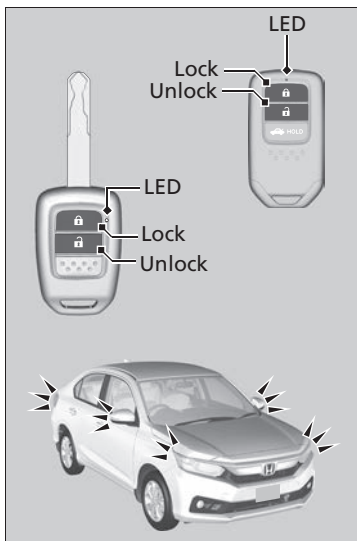

■ Locking the doors

Press the lock button.

- ▶ Some exterior lights flash once, all the doors lock.

■ Unlocking the doors

Press the unlock button.

- ▶ Some exterior lights flash twice, all the doors unlock.

▶▶ Using the Remote Transmitter*

If you do not open a door within 30 seconds of unlocking the vehicle with the remote transmitter, the doors will automatically relock.

Models without keyless access system

The remote transmitter will not work when the key is in the ignition switch.

Models with keyless access system

You can lock or unlock doors and boot using the remote transmitter only when the power mode is in VEHICLE OFF.

The remote transmitter uses low-power signals, so the operating range may vary depending on the surroundings.

The remote transmitter will not lock the vehicle when a door is open.

If the distance at which the remote transmitter works varies, the battery is probably low. If the LED does not come on when you press a button, the battery is dead.

▶▶ **Replacing the Button Battery** P. 274

■ Locking/Unlocking the Doors Using a Key

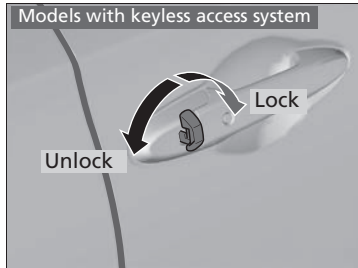
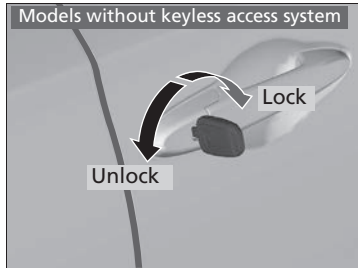

Fully insert the key and turn it.

▣ Locking/Unlocking the Doors Using a Key

When you lock/unlock the driver's door with the key, all the other doors lock/unlock at the same time.

Continued

■ Locking a Door Without Using a Key

If you do not have the key on you, or if for some reason you cannot lock a door using the key, you can lock the door without it.

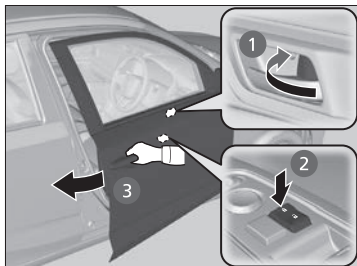

■ Locking the driver's door

Push the lock tab forward ① or push the master door lock switch* in the lock direction ②, then pull and hold the outside door handle ③. Close the door, then release the handle.

■ Locking the passengers' doors

Push the lock tab forward and close the door.

■ Lockout prevention system

Models without keyless access system

The driver's door cannot be locked when the key is in the ignition switch.

Models with keyless access system

The doors cannot be locked when the keyless remote is inside the vehicle.

▶ Locking a Door Without Using a Key

When you lock the driver's door, all the other doors lock at the same time.

Before locking a door, make sure that the key is not inside the vehicle.

Locking/Unlocking the Doors from the Inside

■ Using the Lock Tab

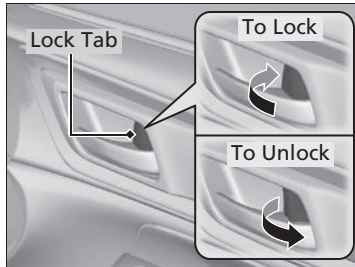

■ **Locking a door**
Push the lock tab forward.

■ **Unlocking a door**
Pull the lock tab rearward.

■ Unlocking Using the Driver's Door Inner Handle

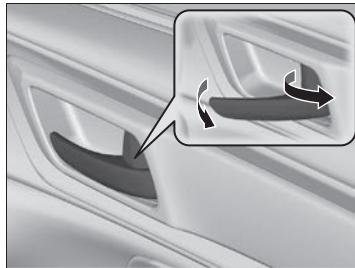

Pull the driver's door inner handle.
▶ The door unlocks and opens in one motion.

Unlocking and opening the driver's door from the inner handle unlocks all the other doors.

▶▶ Using the Lock Tab

When you lock/unlock the door using the lock tab on the driver's door, all the other doors lock/unlock at the same time.

▶▶ Unlocking Using the Driver's Door Inner Handle

The driver's door inner handle is designed to allow the driver to open the door in one motion. However, this feature requires that the driver never pull the door inner handle while the vehicle is in motion.

Children should always ride in a rear seat where childproof door locks are provided.

▶ **Childproof Door Locks** P. 100

■ Using the Master Door Lock Switch*

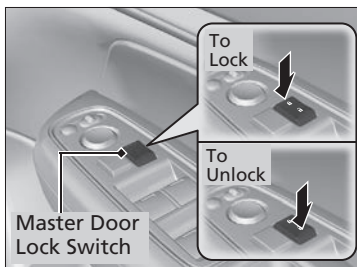

Press the master door lock switch in as shown to lock or unlock all the doors.

Childproof Door Locks

The childproof door locks prevent the rear doors from being opened from the inside regardless of the position of the lock tab.

■ Setting the Childproof Door Locks

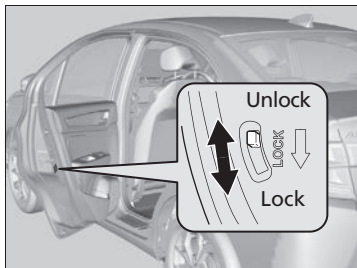

Slide the lever in the rear door to the lock position, and close the door.

■ When opening the door

Open the door using the outside door handle.

☒ Childproof Door Locks

To open the door from the inside when the childproof door lock is on, put the lock tab in the unlock position, lower the rear window, put your hand out of the window, and pull the outside door handle.

Auto Door Locking/Unlocking*

Your vehicle locks or unlocks all doors automatically when a certain condition is met.

■ Auto Door Locking

■ Drive lock mode

All doors lock when the vehicle's speed reaches about 15 km/h.

■ Auto Door Unlocking

Continuously variable transmission models

■ Park unlock mode

All doors unlock when the transmission is put into **P** with the brake pedal depressed.

Manual transmission models

■ Ignition switch unlock mode

All doors unlock when the ignition switch is moved out of ON **II***1.

*1: Models with the keyless access system have an **ENGINE START/STOP** button instead of an ignition switch.

* Not available on all models

Customizing the Auto Door Locking/Unlocking Setting*

You can customize the auto door locking/unlocking setting to your liking using the master door lock switch.

List of the Auto Door Locking/Unlocking Customizable Options

Auto door locking

Mode	Description
Drive Lock Mode ^{*1}	All doors lock when the vehicle's speed reaches about 15 km/h.
Continuously variable transmission models Park Lock Mode	All doors lock when the transmission is taken out of P with the brake pedal depressed.
Off	The auto door locking is deactivated all the time.

Auto door unlocking

Mode	Description
Continuously variable transmission models Park Unlock Mode ^{*1}	All doors unlock when the transmission is put into P with the brake pedal depressed.
Manual transmission models Ignition Switch Unlock Mode ^{*1}	All doors unlock when the ignition switch is moved out of ON II ^{*2} .
Off	The auto door unlocking is deactivated all the time.

*1: Default setting

*2: Models with the keyless access system have an **ENGINE START/STOP** button instead of an ignition switch.

Customizing Flow for Auto Door Locking Options

Steps	Drive Lock Mode	Park Lock Mode* ¹	Off
1	Apply the parking brake. Make sure the shift lever is in P . ^{*1}		
2	Turn the ignition switch to ON II . ^{*2}		
3	The driver's door must be closed at this stage.		Open the driver's door.
4	Move the shift lever out of P with the brake pedal depressed. ^{*1}	-	
5	Press and hold the front of the master door lock switch on the driver's door for more than five seconds. Release the switch after you hear a click twice.		
6	Move the shift lever to P . ^{*1}	-	
7	Turn the ignition switch to LOCK 0 . ^{*2} within 20 seconds. ► Customization is completed.		

*1: Continuously variable transmission models only

*2: Models with the keyless access system have an **ENGINE START/STOP** button instead of an ignition switch.

■ Customizing Flow for Auto Door Unlocking Options

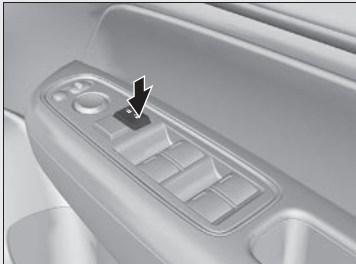
Steps	Ignition Switch Unlock Mode*1	Park Unlock Mode*2	Off
1	Apply the parking brake. Make sure the shift lever is in P *2.		
2	Turn the ignition switch to ON II *3.		
3	The driver's door must be closed at this stage.		Open the driver's door.
4	–	Move the shift lever out of P with the brake pedal depressed.*2	–
5	Press and hold the rear of the master door lock switch on the driver's door for more than five seconds. You will hear a click twice. 		
6	–	Move the shift lever to P *2.	–
7	Turn the ignition switch to LOCK 0 *3 within 20 seconds. ▶ Customization is completed.		

*1:Manual transmission models only

*2:Continuously variable transmission models only

*3:Models with the keyless access system have an **ENGINE START/STOP** button instead of an ignition switch.

Opening and Closing the Boot

Precautions for Opening/Closing the Boot

■ Opening the boot

Open the boot all the way.

- ▶ If it is not fully opened, the boot lid may begin to close under its own weight.

■ Closing the boot

Keep the boot lid closed while driving to:

- ▶ Avoid possible damage.
 - ▶ Prevent exhaust gas from leaking into the vehicle.
- 🚫 **Exhaust Gas Hazard** P. 68

Using the Key*

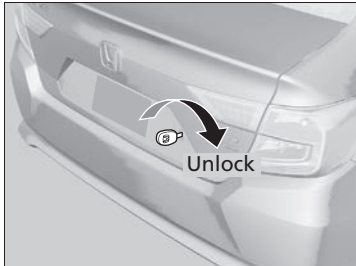

Insert the key in the cylinder to unlock and open the boot.

* Not available on all models

Using the Boot Opener

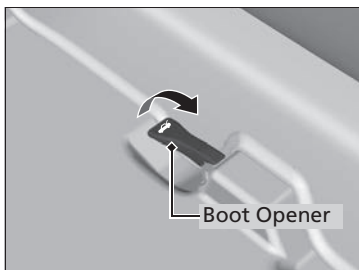

Pulling the boot opener on the outside of the driver's seat unlocks and opens the boot.

Using the Remote Transmitter *

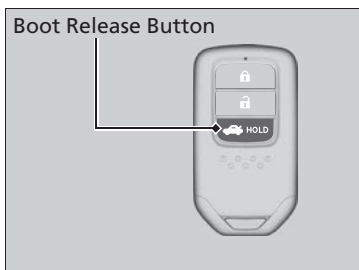

Press the boot release button for approximately one second to unlock and open the boot.

Using the Boot Release Button *

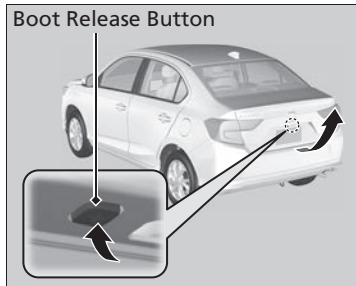

Push up the release button on the boot lid after the doors are unlocked.

Even if the boot is locked, you can open the boot if you carry the keyless remote.

- ▶ Some exterior lights flash twice and the beeper sounds once.

Using the Boot Release Button *

- If you forget the keyless remote inside, the beeper will sound and the boot will not close.
- A person who is not carrying the keyless remote can unlock the boot if a person who is carrying it is within range.
- If the beeper sounds after you close the boot, move the keyless remote away from the boot and close again.
- The keyless remote may not operate if it is too close to the boot.

* Not available on all models

Immobilizer System

The immobilizer system prevents a key that has not been pre-registered from starting the engine. Each key contains electronic transmitters that use electronic signals to verify the key.

Pay attention to the following when inserting the key into the ignition switch or pressing the **ENGINE START/STOP** button:

- Do not allow objects that emit strong radio waves near the ignition switch or the **ENGINE START/STOP** button.
- Make sure the key is not covered by or touching a metal object.
- Do not bring a key from another vehicle's immobilizer system near the ignition switch or the **ENGINE START/STOP** button.
- Do not put the key near magnetic items. Electronic device, such as televisions and audio systems emit strong magnetic fields. Note that even a key chain can become magnetic.

Immobilizer System

NOTICE

Leaving the key in the vehicle can result in theft or accidental movement of the vehicle. Always take the key with you whenever you leave the vehicle unattended.

Do not alter the system or add other devices to it. Doing so may damage the system and make your vehicle inoperable.

If the system repeatedly does not recognise the coding of your key, contact your dealer. If you have lost your key and cannot start your engine, contact a dealer.

Opening and Closing the Windows

Opening/Closing the Power Windows

The power windows can be opened and closed when the ignition switch is in ON ¹, using the switches on the doors.

The driver's side switches can be used to open and close all the windows. The power window lock button on the driver's side must be switched off (not pushed in) to open and close the windows from anywhere other than the driver's seat.

When the power window lock button is pushed in, you can only operate the driver's window. Turn the power window lock button on if a child is in the vehicle.

Opening/Closing Windows with Auto-Open/Close* Function

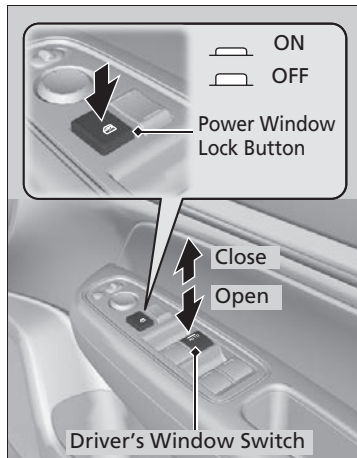

Manual operation

To open: Push the switch down lightly, and hold it until the desired position is reached.

To close: Pull the switch up lightly, and hold it until the desired position is reached.

Automatic operation

To open: Push the switch down firmly.

To close*: Pull the switch up firmly.

The window opens or closes* completely. To stop the window at any time, push or pull the switch briefly.

*1: Models with the keyless access system have an **ENGINE START/STOP** button instead of an ignition switch.

* Not available on all models

Opening/Closing the Power Windows

WARNING

Closing a power window on someone's hands or fingers can cause serious injury.

Make sure your passengers are away from the windows before closing them.

WARNING: Always take the ignition key with you whenever you leave the vehicle alone or with other occupants.

You cannot fully open the rear windows.

Models with auto-close function

Auto Reverse

If a power window senses resistance when closing automatically, it will stop closing and reverse direction.

The driver's window auto reverse function is disabled when you continuously pull up the switch.

The auto reverse function stops sensing when the window is almost closed to ensure that it fully closes.

Continued

■ Opening/Closing Windows without Auto-Open/Close Function

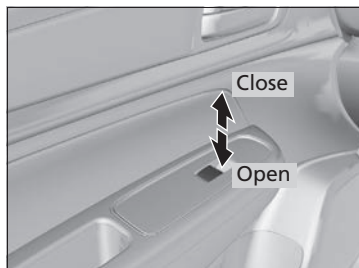

To open: Push the switch down.

To close: Pull the switch up.

Release the switch when the window reaches the desired position.

Operating the Switches Around the Steering Wheel

Models without keyless access system

Ignition Switch

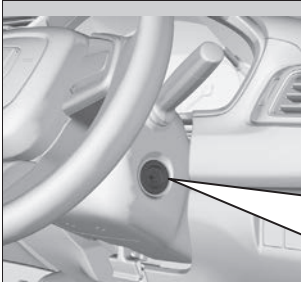

- 0** LOCK: Insert and remove the key in this position.
- I** ACCESSORY: Operate the audio system* and other accessories in this position.
- II** ON: This is the position when driving.
- III** START: This position is for starting the engine. The switch returns to ON **II** when you let go of the key.

* Not available on all models

» Ignition Switch

Manual transmission models

! WARNING

Removing the key from the ignition switch while driving locks the steering. This can cause you to lose control of the vehicle.

Remove the key from the ignition switch only when parked.

Continuously variable transmission models

You cannot take the key out unless the shift lever is in **P**.

If you open the driver's door when the key is in LOCK **0** or ACCESSORY **I**, a warning buzzer will sound to remind you to take the key out.

If the key won't turn from LOCK **0** to ACCESSORY **I**, turn the key while moving the steering wheel left and right. The steering wheel will unlock, allowing the key to turn.

Models with keyless access system

ENGINE START/STOP Button

Changing the Power Mode

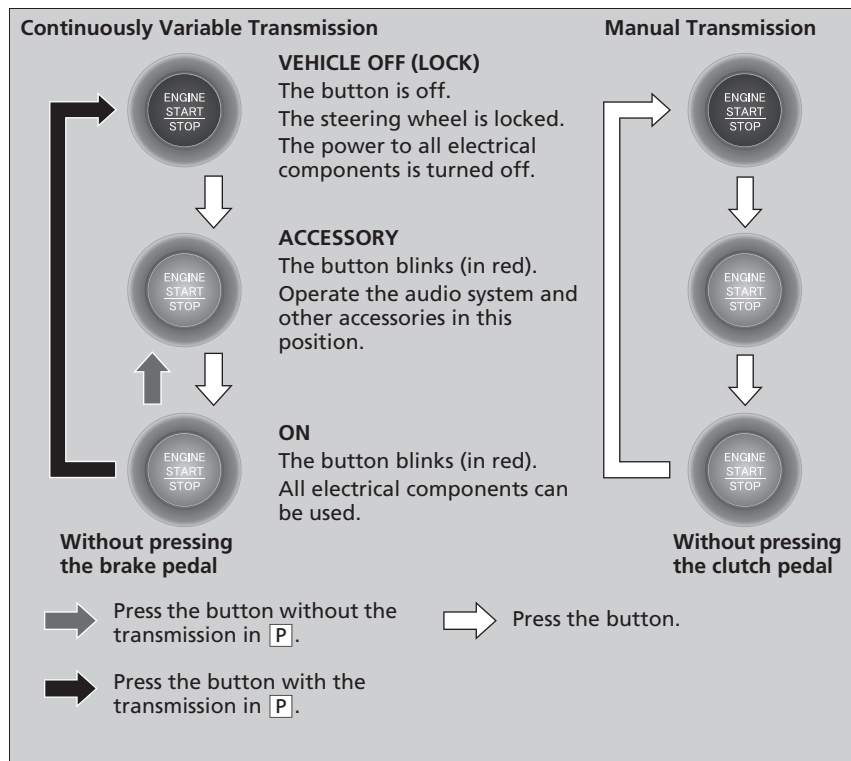

Controls

ENGINE START/STOP Button

ENGINE START/STOP Button Operating Range

You can start the engine when the keyless remote is inside the vehicle.

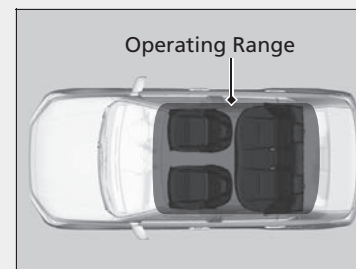

If the battery of the keyless remote is getting low, the engine may not start when you push the **ENGINE START/STOP** button. If the engine does not start, refer to the following link.

➔ **If the Keyless Remote Battery is Weak**
P. 292

The engine may also run if the keyless remote is close to the door or window, even if it is outside the vehicle.

ON mode:
The **ENGINE START/STOP** button is on (in red), if the engine is running.

■ Automatic Power Off

If you leave the vehicle for 30 to 60 minutes with the transmission in **P***1 and the power mode in ACCESSORY, the vehicle automatically goes into the mode similar to VEHICLE OFF (LOCK) to avoid draining the battery.

When in this mode:

The steering wheel does not lock.

You cannot lock or unlock doors with the remote transmitter or the keyless access system.

Press the **ENGINE START/STOP** button twice to switch the mode to VEHICLE OFF (LOCK).

*1: Continuously variable transmission models

▣ ENGINE START/STOP Button

If the power mode does not change from VEHICLE OFF to ACCESSORY, press the **ENGINE START/STOP** button while moving the steering wheel left and right. The steering wheel will unlock, allowing the mode to change.

Do not leave the power mode in ACCESSORY or ON when you get out.

Continued

Power Mode Reminder

If you open the driver's door when the power mode is set to ACCESSORY, a warning beep sounds.

Keyless Remote Reminder

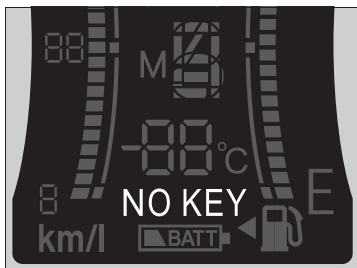

Warning buzzers may sound from inside and/or outside the vehicle to remind you that the keyless remote is out of the vehicle. If the buzzer continues even after the remote is put back inside, place it to be within its operational range.

■ When the power mode is in ON

If the keyless remote is taken out of the vehicle, and all the doors are closed, a warning buzzer sounds from both inside and outside the vehicle. A warning message on the information display notifies the driver inside that the remote is outside of the vehicle.

■ When the power mode is in ACCESSORY

If the keyless remote is taken out of the vehicle, and all the doors are closed, a warning buzzer sounds from outside the vehicle.

⊗ Keyless Remote Reminder















When the keyless remote is within the system's operational range, and the driver's door is closed, the warning function cancels.

If the keyless remote is taken out of the vehicle after the engine has been started, you can no longer change the **ENGINE START/STOP** button mode or restart the engine. Always make sure if the remote is in your vehicle when you operate the **ENGINE START/STOP** button.

Removing the keyless remote from the vehicle through a window does not activate the warning buzzer.

Do not put the keyless remote on the dashboard or in the glove box. It may cause the warning buzzer to go off. Under some other conditions that can prevent the vehicle from locating the remote, the warning buzzer may also go off even if the remote is within the system's operational range.

Ignition Switch and Power Mode Comparison

Ignition Switch Position	LOCK  (with/without the key) 	ACCESSORY  	ON  	START  
Without Keyless Access System	<ul style="list-style-type: none"> • Engine is turned off and power is shut down. • The steering wheel is locked. • No electrical components can be used. 	<ul style="list-style-type: none"> • Engine is turned off. • Some electrical components such as the audio system and the accessory power socket can be operated. 	<ul style="list-style-type: none"> • Normal key position while driving. • All electrical components can be used. 	<ul style="list-style-type: none"> • Use this position to start the engine. • The ignition switch returns to ON  position when you release the key.
Power Mode	VEHICLE OFF (LOCK) 	ACCESSORY 	ON   Button is: Blinking On	START 
With Keyless Access System and ENGINE START/STOP Button	Button-Off <ul style="list-style-type: none"> • Engine is turned off and power is shut down. • The steering wheel is locked. • No electrical components can be used. 	Button-Blinking <ul style="list-style-type: none"> • Engine is turned off. • Some electrical components such as the audio system and the accessory power socket can be operated. 	Button-Blinking (engine is turned off) On (engine is running) <ul style="list-style-type: none"> • All electrical components can be used. 	Button-On <ul style="list-style-type: none"> • The mode automatically returns to ON after the engine starts.

Turn Signals

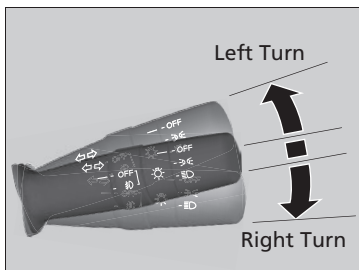

The turn signals can be used when the ignition switch is in ON ^{*1}.

■ One-touch turn signal

When you lightly push up or down and release the turn signal lever, the exterior turn signals and turn signal indicator blink three times.

This feature can be used when signalling for a lane change.

*1: Models with the keyless access system have an **ENGINE START/STOP** button instead of an ignition switch.

Light Switches

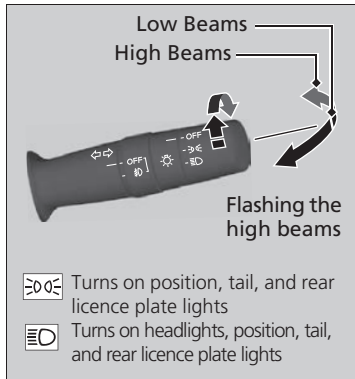

Rotating the light switch turns the lights on and off, regardless of the power mode setting* or position of the ignition switch*.

■ High beams

Push the lever forward until you hear a click.

■ Low beams

When in high beams, pull the lever back to return to low beams.

■ Flashing the high beams

Pull the lever back, and release it.

■ Automatic lighting off feature

The headlights, all other exterior lights, and the instrument panel lights turn off 15 seconds after you remove the key* or set the power mode to VEHICLE OFF (LOCK)*, take the remote* with you, and close the driver's door.

If you turn the ignition switch to LOCK [0]*1 with the headlight switch on, but do not open the door, the lights turn off after 10 minutes.

The lights turn on again when you unlock or open the driver's door. If you unlock the door, but do not open it within 15 seconds, the lights go off. If you open the driver's door, you will hear a lights on reminder chime.

*1: Models with the keyless access system have an **ENGINE START/STOP** button instead of an ignition switch.

* Not available on all models

▶▶ Light Switches

Models without keyless access system

If you remove the key from the ignition switch while the lights are on, a chime sounds when the driver's door is opened.

Models with keyless access system

If you leave the power mode in VEHICLE OFF while the lights are on, a chime sounds when the driver's door is opened.

When the lights are on, the lights on indicator in the instrument panel will be on.

▶ Lights On Indicator P. 79

Do not leave the lights on when the engine is off because it will cause the battery to discharge.

Fog Lights *

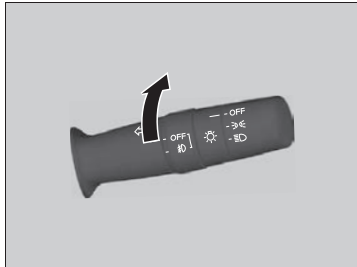

Can be used when the position lights or the headlights are on.

Controls

Headlight Adjuster

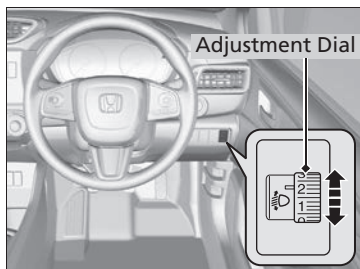

You can adjust the vertical angle of the low beam headlights when the position lights are on.

Turn the adjustment dial to select an appropriate angle for the headlights.

The larger dial number indicates the lower angle.

■ To select the adjustment dial position

Refer to the below table for the appropriate dial position for your vehicle's riding and loading conditions.

Condition	Dial position
A driver or driver and passenger in the front seat.	0
Five persons in the front and rear seats.	1
Five persons in the front and rear seats and luggage in the boot within the limits of maximum permissible vehicle weight.	2
A driver and luggage in the boot within the limits of maximum permissible vehicle weight.	3

Wipers and Washers

■ Windscreen Wipers/Washers

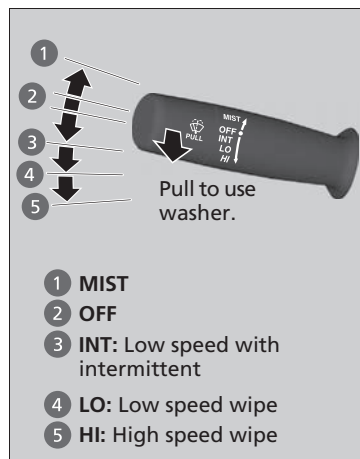

The windscreen wipers and washers can be used when the ignition switch is in ON **II***1.

■ MIST

The wipers run at high speed until you release the lever.

■ Wiper switch (OFF, INT, LO, HI)

Move the lever up or down to change the wiper settings.

■ Washer

Sprays while you pull the lever toward you. When you release the lever for more than one second, the spray stops, the wipers sweep two or three more times to clear the windscreen, then stop.

▶ Wipers and Washers

NOTICE

Do not use the wipers when the windscreen is dry. The windscreen will get scratched, or the rubber blades will get damaged.

Turn the washers off if no washer fluid comes out. The pump may get damaged.

NOTICE

In cold weather, the blades may freeze to the windscreen. Operating the wipers in this condition may damage the wipers. Use the demister to warm the windscreen, then turn the wipers on.

If the wipers stop operating due to an obstacle such as the build-up of snow, park the vehicle in a safe place.

Rotate the wiper switch to **OFF**, and turn the ignition switch to ACCESSORY **I***1 or LOCK **0***1, then remove the obstacle.

The wiper motor is equipped with a breaker that may stop motor operation temporarily to prevent an overload. Wiper operation will return to normal within a few minutes, once the circuit has returned to normal.

*1: Models with the keyless access system have an **ENGINE START/STOP** button instead of an ignition switch.

Rear Demister Button *

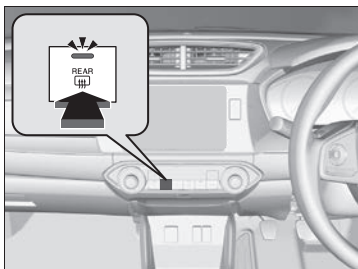

Press the rear demister button to defog the rear window when the power mode is in ON.

The rear demister automatically switches off after 10-30 minutes depending on the outside temperature. However, if the outside temperature is 0°C or below, it does not automatically switch off.

»» Rear Demister Button *

NOTICE

When cleaning the inside of the rear window, be careful not to damage the heating wires. It is critical to wipe the window from side to side along the demister heating wires.

This system consumes a lot of power, so turn it off when the window has been demisted. Also, do not use the system for a long time when the engine is idling. This may weaken the battery, making it difficult to start the engine.

* Not available on all models

Brightness Control



When the position lights are turned on and the ignition switch is in ON **II***1, you can use the **TRIP** knob to adjust instrument panel brightness.

Brighten: Turn the knob to the right.

Dim: Turn the knob to the left.

You will hear a beep when the brightness reaches minimum or maximum. Several seconds after you have adjusted the brightness, you will be returned to the previous screen.

☒ Brightness Control

Instrument panel brightness varies, depending on whether the exterior lights are on or off. The instrument panel dims to reduce glare when they are on.

To cancel the reduced instrument panel brightness when the exterior lights are on, turn the knob to the right until the brightness display is up to max, the beeper sounds.

The brightness can be set differently for when the exterior lights are on, and when they are off.

*1: Models with the keyless access system have an **ENGINE START/STOP** button instead of an ignition switch.

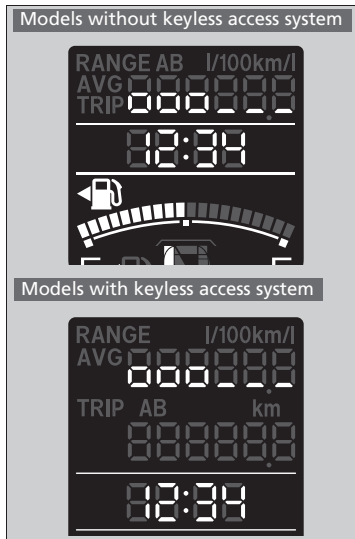

■ **Brightness level indicator**

The brightness level is shown on the information display while you are adjusting it.



Controls



Adjusting the Steering Wheel*

The steering wheel height from your body can be adjusted so that you can comfortably grip the steering wheel in an appropriate driving posture.

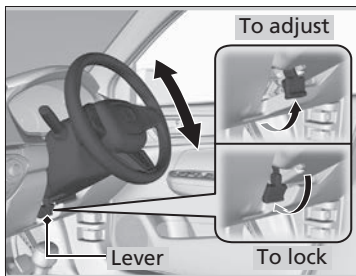

1. Pull the steering wheel adjustment lever up.
 - ▶ The steering wheel adjustment lever is under the steering column.
2. Move the steering wheel up or down.
 - ▶ Make sure you can see the instrument panel gauges and indicators.
3. Push the steering wheel adjustment lever down to lock the steering wheel in position.
 - ▶ After adjusting the position, make sure you have securely locked the steering wheel in place by trying to move it up and down.

Adjusting the Steering Wheel *

⚠ WARNING

Adjusting the steering wheel position while driving may cause you to lose control of the vehicle and be seriously injured in a crash.

Adjust the steering wheel only when the vehicle is stopped.

Adjusting the Mirrors

Interior Rearview Mirror

Adjust the angle of the rearview mirror when you are sitting in the correct driving position.

■ Rearview Mirror with Day and Night Positions

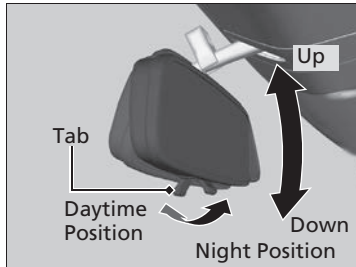

Flip the tab to switch the position. The night position will help to reduce the glare from headlights behind you when driving after dark.

Power Door Mirrors *

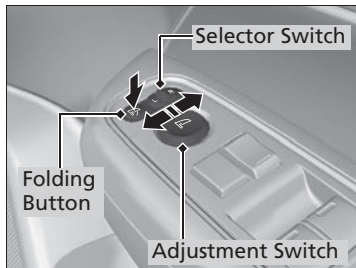

You can adjust the door mirrors when the ignition switch is in ON *1.

■ Mirror position adjustment

L/R selector switch: Select the left or right mirror. After adjusting the mirror, return the switch to the centre position.

Mirror position adjustment switch: Press the switch left, right, up, or down to move the mirror.

■ Folding door mirrors

Press the folding button to fold in and out the door mirrors.

*1 : Models with the keyless access system have an **ENGINE START/STOP** button instead of an ignition switch.

* Not available on all models

▣ Adjusting the Mirrors

Keep the inside and outside mirrors clean and adjusted for best visibility.

Adjust the mirrors before you start driving.

▣ **Front Seats** P. 126

Adjusting the Seats

Front Seats

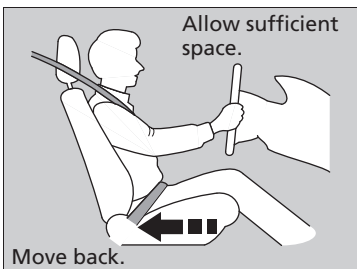

Adjust the driver's seat as far back as possible while allowing you to maintain full control of the vehicle. You should be able to sit upright, well back in the seat and be able to adequately press the pedals without leaning forward, and grip the steering wheel comfortably. The passenger's seat should be adjusted in a similar manner, so that it is as far back from the front airbag in the dashboard as possible.

Adjusting the Seats

⚠ WARNING

Sitting too close to a front airbag can result in serious injury or death if the front airbags inflate.

Always sit as far back from the front airbags as possible while maintaining control of the vehicle.

Adjusting the Seat Positions

Adjusting the front seats

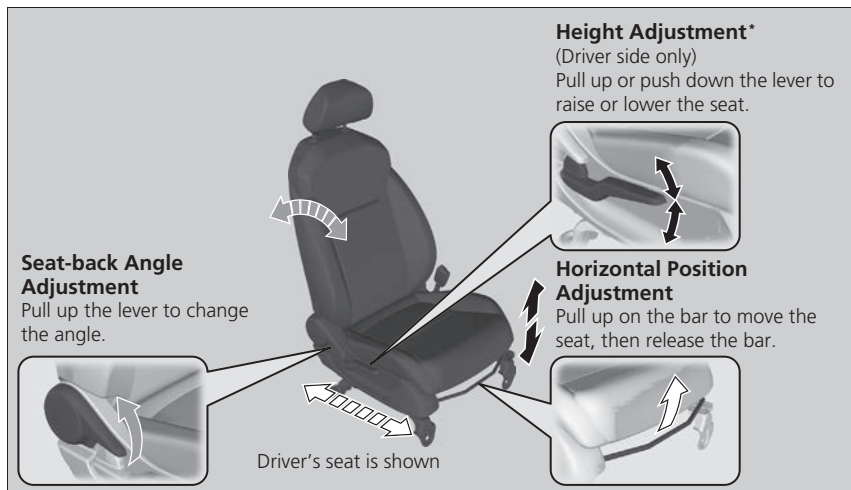

In addition to the seat adjustment, you can adjust the steering wheel up and down*. Allow at least 25 cm between the centre of the steering wheel and the chest.

Always make seat adjustments before driving.

Once a seat is adjusted correctly, rock it back and forth to make sure it is locked in position.

■ Adjusting the Seat-Backs

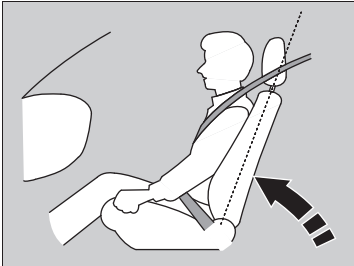

Adjust the driver's seat-back to a comfortable, upright position, leaving ample space between your chest and the airbag cover in the centre of the steering wheel.

The front seat passenger should also adjust their seat-back to a comfortable, upright position.

Reclining a seat-back so that the shoulder part of the belt no longer rests against the occupant's chest reduces the protective capability of the belt. It also increases the chance of sliding under the belt in a crash and being seriously injured. The farther a seat-back is reclined, the greater the risk of injury.

▣ Adjusting the Seat-Backs

⚠ WARNING

Reclining the seat-back too far can result in serious injury or death in a crash.

Adjust the seat-back to an upright position, and sit well back in the seat.

Do not put a cushion, or other object, between the seat-back and your back.

Doing so may interfere with proper seat belt or airbag operation.

If you cannot get far enough away from the steering wheel and still reach the controls, we recommend that you investigate whether some type of adaptive equipment may help.

Maintain a Proper Sitting Position

After all occupants have adjusted their seats and head restraints*, and put on their seat belts, it is very important that they continue to sit upright, well back in their seats, with their feet on the floor, until the vehicle is safely parked and the engine is off.

Sitting improperly can increase the chance of injury during a crash. For example, if an occupant slouches, lies down, turns sideways, sits forward, leans forward or sideways, or puts one or both feet up, the chance of injury during a crash is greatly increased.

In addition, an occupant who is out of position in the front seat can be seriously or fatally injured in a crash by striking interior parts of the vehicle or being struck by an inflating front airbag.

► Maintain a Proper Sitting Position

⚠ WARNING

Sitting improperly or out of position can result in serious injury or death in a crash.

Always sit upright, well back in the seat, with your feet on the floor.

Head Restraints

Your vehicle is equipped with head restraints in both front seating positions.

■ Adjusting the Front Head Restraints*

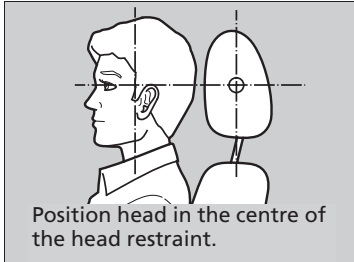

Head restraints are most effective for protection against whiplash and other rear-impact crash injuries when the centre of the back of the occupant's head rests against the centre of the restraint. The tops of the occupant's ears should be level with the centre height of the restraint.

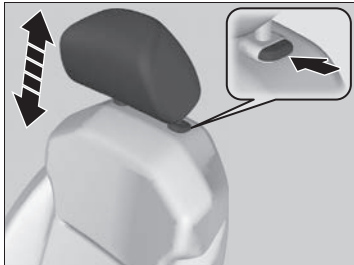

To raise the head restraint: Pull it upward.
To lower the head restraint: Push it down while pressing the release button.

▶▶ Adjusting the Front Head Restraints*

⚠ WARNING

Improperly positioning head restraints reduces their effectiveness and increases the likelihood of serious injury in a crash.

Make sure head restraints are in place and positioned properly before driving.

In order for the head restraint system to work properly:

- Do not hang any items on the head restraints, or from the restraint legs.
- Do not place any object between an occupant and the seat-back.
- Install each restraint in its proper location.

* Not available on all models

Continued

■ Removing and Reinstalling the Head Restraints *

Adjustable head restraints can be removed for cleaning or repair.

To remove a head restraint:

Pull the restraint up as far as it will go. Then push the release button, and pull the restraint up and out.

To reinstall a head restraint:

Insert the legs back in place, then adjust the head restraint to an appropriate height while pressing the release button. Pull up on the restraint to make sure it is locked in position.

► Removing and Reinstalling the Head Restraints *

⚠ WARNING

Failure to reinstall, or correctly reinstall, the head restraints can result in severe injury during a crash.

Always replace the head restraints before driving.

Armrest*

■ Using the Rear Seat Armrest

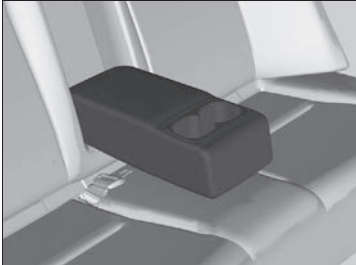

Pull down the armrest in the centre seat-back.

* Not available on all models

Interior Lights

Interior Light Switch

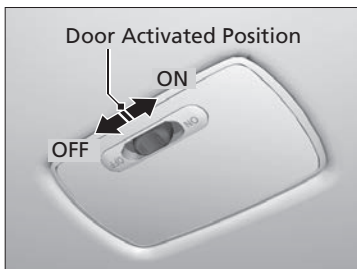

Controls

■ ON

The interior light comes on regardless of whether the doors are open or closed.

■ Door activated

The interior light comes on in the following situations:

- When any doors are opened.
- You unlock the driver's door.

Models without keyless access system

- You remove the key from the ignition switch.

Models with keyless access system

- When the power mode is set to VEHICLE OFF.

■ OFF

The interior light remains off regardless of whether the doors are open or closed.

Interior Light Switch

In the door activated position, the interior light fades out and goes off about 30 seconds after the doors are closed.

The light goes off after about 30 seconds in the following situations:

- When you unlock the driver's door but do not open it.

Models without keyless access system

- When you remove the key from the ignition switch but do not open a door.

Models with keyless access system

- When you set the power mode to VEHICLE OFF but do not open a door.

The interior light goes off immediately in the following situations:

- When you lock the driver's door.

Models without keyless access system

- When you close the driver's door with the key in the ignition switch.
- When you turn the ignition switch to ON **II**.

Models with keyless access system

- When you set the power mode to ON.
- When you close the driver's door in ACCESSORY mode.

To avoid draining the battery, do not leave the interior light on for an extended length of time when the engine is off.

If you leave any of the doors open in VEHICLE OFF mode, or without the key in the ignition switch, the interior lights go off after about 15 minutes.

Interior Convenience Items

Glove Box

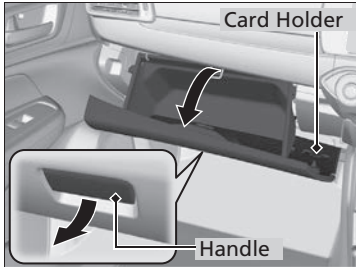

Pull the handle to open the glove box.

You can use the card holder located in the glove box lid.

Glove Box

⚠ WARNING

An open glove box can cause serious injury to your passenger in a crash, even if the passenger is wearing the seat belt.

Always keep the glove box closed while driving.

Continued

Beverage Holders

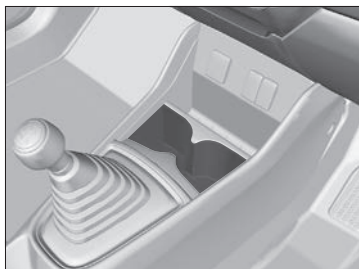

■ Front seat beverage holders

Are located in the console between the front seats.

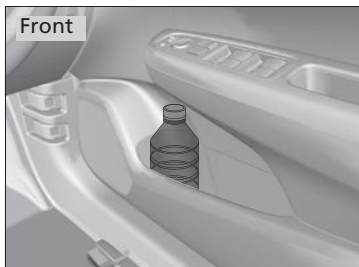

■ Door side beverage holders

Are located on the both of front and rear door side pockets.



☒ Beverage Holders

NOTICE

Spilled liquids can damage the upholstery, carpeting, and electrical components in the interior.

Be careful when you are using the beverage holders. Hot liquid can scald you.

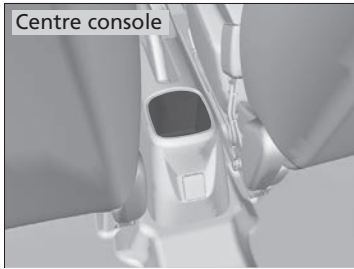

■ **Rear seat beverage holder**

Are located in the console between the front seats.

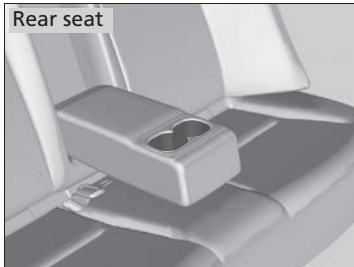

Fold the armrest* down to use the rear seat beverage holders.

* Not available on all models

Continued

Accessory Power Sockets

The accessory power sockets can be used when the ignition switch must be ACCESSORY **I***1 or ON **II***1.

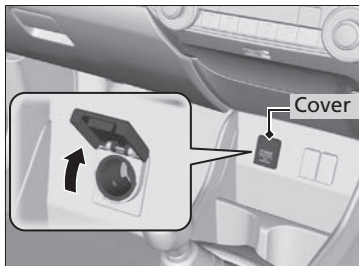

Accessory power socket (front console)

Open the cover to use it.

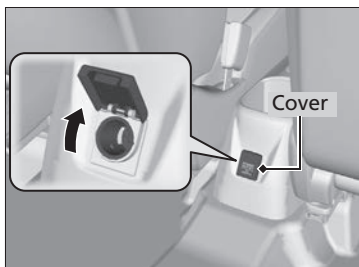

Accessory power socket (centre console)*

Open the cover to use it.

Accessory Power Sockets

NOTICE

Do not insert an automotive type cigarette lighter element.

This can overheat the power socket.

The accessory power socket is designed to supply power for 12-volt DC accessories that are rated 180 watts or less (15 amps).

To prevent battery drain, only use the power socket with the engine running.

*1: Models with the keyless access system have an **ENGINE START/STOP** button instead of an ignition switch.

Heating and Cooling System*

Using Vents, Heating and A/C

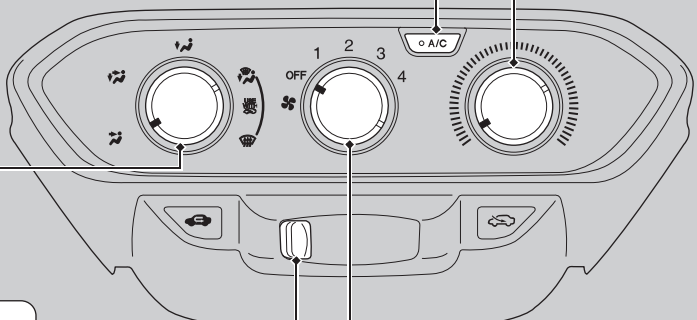



A/C (Air Conditioning) Button
Press to cool the interior or dehumidify while heating.

Temperature Control Dial
Adjusts the interior temperature.





Mode Control Dial
Changes airflow.

Fan Control Dial
Adjusts the fan speed. Rotate the dial all the way to **OFF** to turn everything off.

Fresh Air/Recirculation Lever

-  **(Fresh Air) Mode**
Maintains outside ventilation. Keep the system in fresh air mode in normal situations.
-  **(Recirculation) Mode**
Recirculates air from the vehicle's interior through the system.

Legend:



-  Dashboard vents
-  Dashboard and floor vents
-  Floor vents
-  Floor and demister vents
-  **Windscreen Demister Mode**
Selects airflow from the demister vents at the base of the windscreen.

* Not available on all models

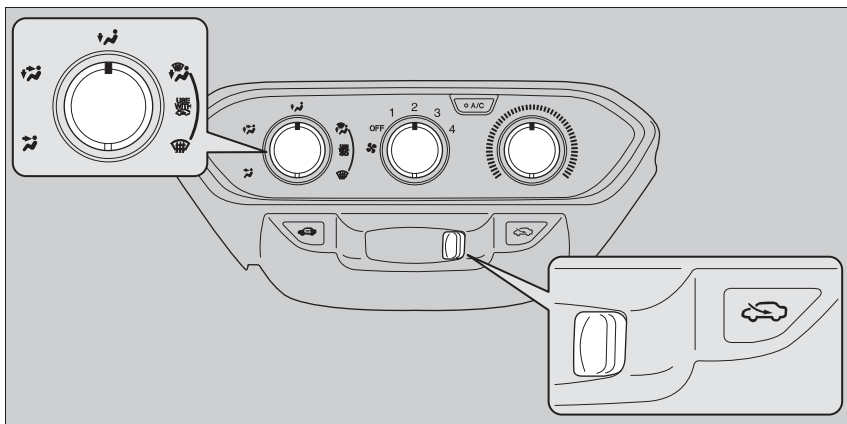

■ Heating



The heater uses engine coolant to warm the air.

1. Adjust the fan speed using the fan control dial.
2. Select .
3. Adjust the temperature using the temperature control dial.
4. Slide the lever to .

■ To rapidly warm up the interior



1. Set the fan to the maximum speed.
2. Select .
3. Set the temperature to maximum warm.
4. Slide the lever to .

☒ To rapidly warm up the interior

Change to fresh air mode as soon as the interior gets warm enough. The windows may fog up if kept in recirculation mode.

■ To dehumidify the interior



When used in combination with the heater, the air conditioning system makes the interior warm and dry and can prevent the windows from fogging up.

1. Turn the fan on.
2. Press the **A/C** button to turn on the air conditioning.
3. Select  and slide the lever to .
4. Adjust the temperature to your preference.

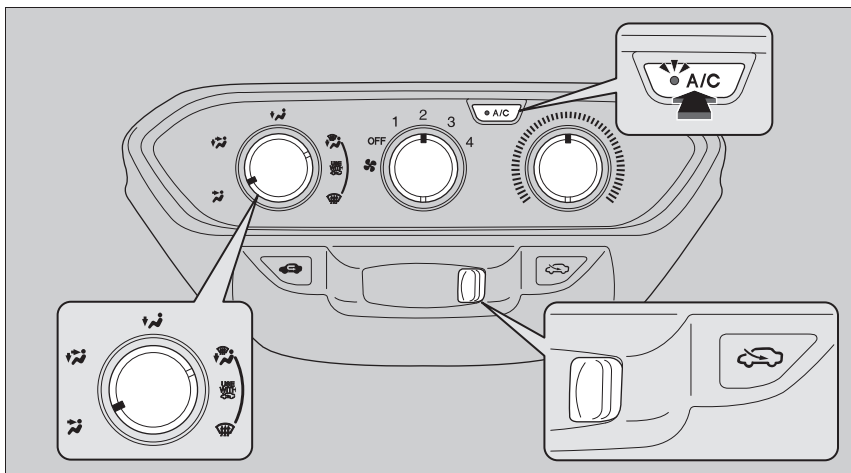

Continued

■ Cooling





1. Adjust the fan speed using the fan control dial.
2. Select .
3. Adjust the temperature using the temperature control dial.
4. Press the **A/C** button (indicator on).
5. Slide the lever to .

■ **To rapidly cool down the interior**

1. Set the fan to the maximum speed.
2. Select .
3. Set the temperature to maximum cool.
4. Press the **A/C** button (the indicator on).
5. Slide the lever to .

■ **To dehumidify the interior**

1. Turn the fan on.
2. Press the **A/C** button to turn on the air conditioning.
3. Select  and slide the lever to .
4. Adjust the temperature so the cooled air feels comfortable.

☒ To rapidly cool down the interior

If the interior is very warm, you can cool it down more rapidly by partially opening the windows.



☒ To dehumidify the interior

If you do not want to use the air conditioning: Setting the fan to the maximum speed and selecting fresh air mode can help removing fog from the inside of the windows.

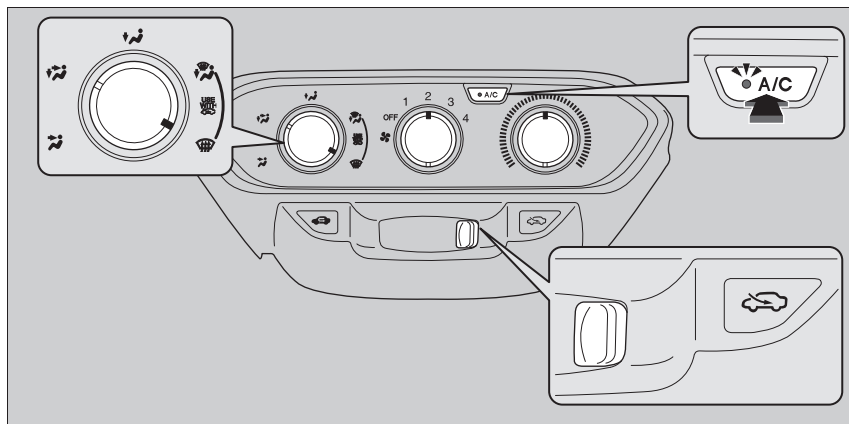

Continued

Defrosting the Windscreen and Windows



1. Set the fan to the high speed.
2. Turn the mode control dial to .
3. Slide the lever to .
4. Press the **A/C** button (the indicator on).
5. Adjust the temperature so the airflow feels warm.

■ To rapidly defrost the windows

1. Set the fan to the maximum speed.
2. Turn the mode control dial to .
3. Press the **A/C** button (the indicator on).
4. Slide the lever to .
5. Set the temperature to maximum warm.

► Defrosting the Windscreen and Windows

For your safety, make sure you have a clear view through all the windows before driving.

Do not set the temperature near the upper or lower limit.

When cold air hits the windscreen, the outside of the windscreen may fog up.

If the side windows fog up, adjust the vents so that the air hits the side windows.

► To rapidly defrost the windows

After defrosting the windows, switch over to fresh air mode.

If you keep the system in recirculation mode, the windows may fog up from humidity. This impedes visibility.

Climate Control System*

Using Automatic Climate Control

The automatic climate control system maintains the interior temperature you select. The system also selects the proper mix of heated or cooled air that raises or lowers the interior temperature to your preference as quickly as possible.

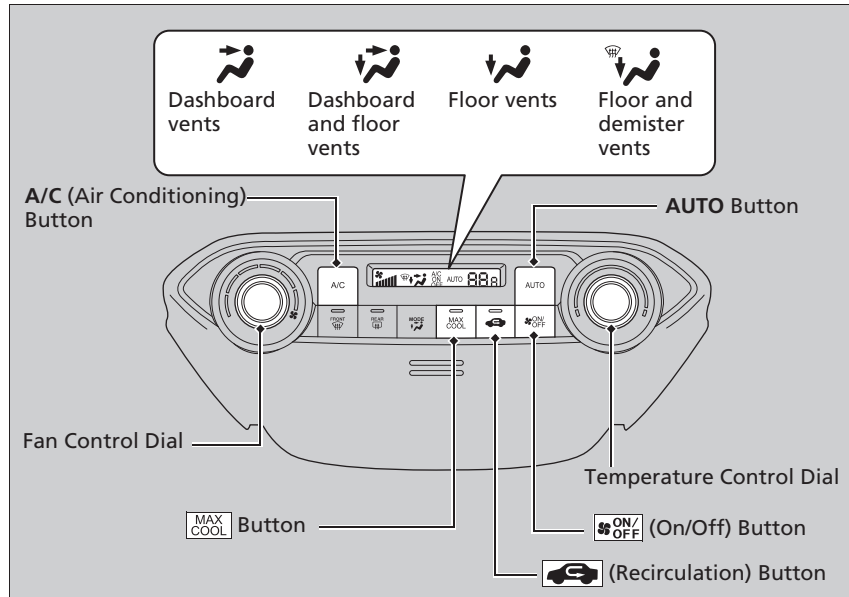

Use the system when the engine is running.

1. Press the **AUTO** button.
2. Adjust the interior temperature using the temperature control dial.
3. Press the **ON/OFF** button to cancel.

* Not available on all models

Using Automatic Climate Control

If any buttons are pressed while using the climate control system in auto, the function of the button that was pressed will take priority.

The **AUTO** indicator will go off, but functions unrelated to the button that were pressed will be controlled automatically.

To prevent cold air from blowing in from outside, the fan may not start immediately when the **AUTO** button is pressed.

If the interior is very warm, you can cool it down more rapidly by partially opening the windows, and pressing the **MAX COOL** button.

When you set the temperature to the lower or upper limit, **Lo** or **Hi** is displayed.

Pressing the **ON/OFF** button switches the climate control system between on and off. The system selects your last selection.

Continued

■ To rapidly cool down the interior

Press the  button.

■ Switching between the recirculation and fresh air modes

Press the  button and switch the mode depending on environmental conditions.

Recirculation Mode (indicator on): Recirculates air from the vehicle's interior through the system.

Fresh Air Mode (indicator off): Maintains outside ventilation. Keep the system in fresh air mode in normal situations.

► To rapidly cool down the interior

If the interior is very warm, you can cool it down more rapidly by partially opening the windows.

■ Defrosting the Windscreen and Windows

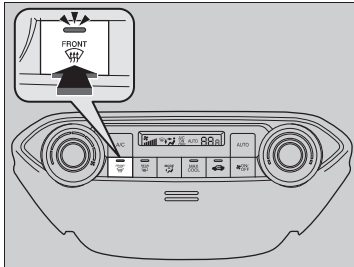

Pressing the  (windscreen demister) button turns the air conditioner system on.

Press the  button again to turn off, the system returns to the previous settings.

■ To rapidly defrost the windows

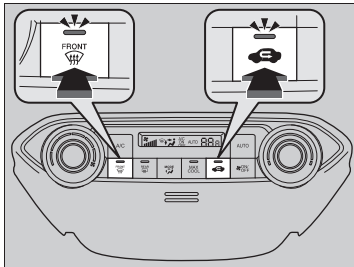

1. Press the  button.
2. Press the  button.

▣ Defrosting the Windscreen and Windows

For your safety, make sure you have a clear view through all the windows before driving.

Do not set the temperature near the upper or lower limit.
When cold air hits the windscreen, the outside of the windscreen may fog up.

If the side windows fog up, adjust the vents so that the air hits the side windows.

▣ To rapidly defrost the windows

After defrosting or defogging the windows, switch over to fresh air mode.

If you keep the system in recirculation mode, the windows may fog up from humidity. This impedes visibility.

Automatic Climate Control Sensors

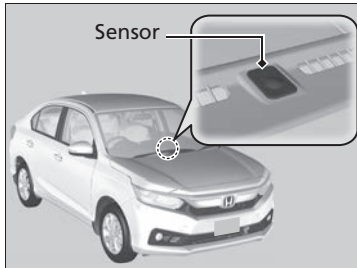

The automatic climate control system is equipped with sensors. Do not cover or spill any liquid on them.

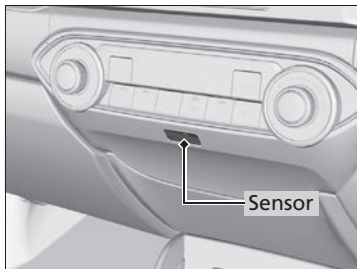

Features

This chapter describes how to operate technology features.

Audio System *

About Your Audio System.....	148
USB Port	149
Auxiliary Input Jack	150
Audio Antenna *	151
Audio Remote Controls.....	152

Audio System Basic Operation *

Adjusting the Sound	154
Playing the AM/FM Radio.....	155
Playing an iPod	158
Playing a USB Flash Drive	161
Playing <i>Bluetooth</i> ® Audio.....	165

Audio Error Messages*

iPod/USB Flash Drive	167
----------------------------	-----

General Information on the Audio System*

Compatible iPod, iPhone, and USB Flash Drives	168
---	-----

Hands-Free Telephone System*

Using HFT	169
HFT Menus	171

* Not available on all models

For AVN audio system: Refer AVN Manual

Audio System*

About Your Audio System

The audio system features AM/FM radio. It can also play WMA/MP3/AAC files, USB flash drives, iPod, and *Bluetooth*® devices.

You can operate the audio system from the buttons and switches on the panel, or the remote controls on the steering wheel.

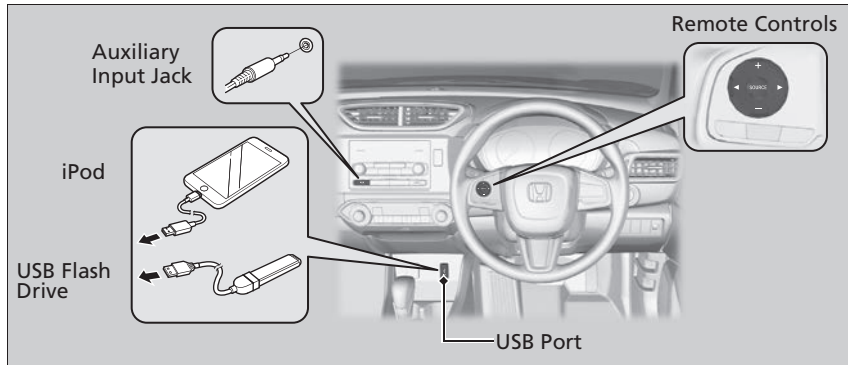

About Your Audio System

iPod, iPhone and iTunes are trademarks of Apple Inc.

USB Port

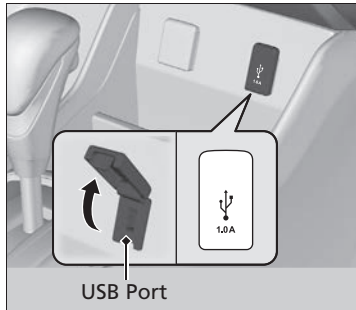

1. Open the cover.
2. Install the iPod USB connector or the USB flash drive to the USB port.

USB Port

- Do not leave the iPod or USB flash drive in the vehicle. Direct sunlight or high temperatures may damage it.
- We recommend using an extension cable with the USB port.
- Do not connect the iPod or USB flash drive using a hub.
- Do not use a device such as a card reader or hard disk drive, as the device or your files may be damaged.
- We recommend backing up your data before using the device in your vehicle.
- Displayed messages may vary depending on the device model and software version.

If the audio system does not recognise the iPod, try reconnecting it a few times or reboot the device. To reboot, follow the manufacturer's instructions provided with the iPod or visit www.apple.com/ipod.

Auxiliary Input Jack

Use the jack to connect a standard audio device.

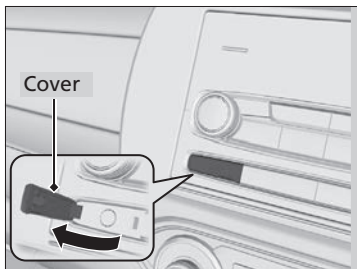

1. Open the **AUX** cover.
2. Connect a standard audio device to the input jack using a 3.5 mm stereo miniplug.
 - ▶ The audio system automatically switches to the AUX mode.

▶▶ Auxiliary Input Jack

To switch the mode or return to the AUX mode, press the **MEDIA** button.

Audio Antenna*

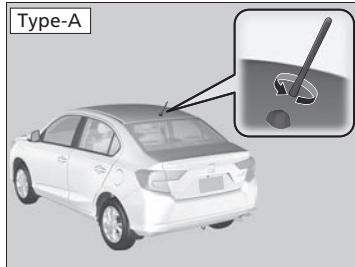

Your vehicle is equipped with a removable antenna at the rear of the roof.

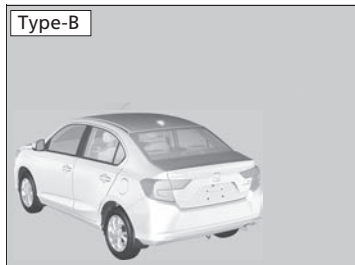

Shark Fin type*

▶▶ Audio Antenna*

NOTICE

Before using a "drive-through" car wash, remove the antenna by unscrewing it by hand. This prevents the antenna from being damaged by the car wash brushes.

* Not available on all models

Audio Remote Controls

Allow you to operate the audio system while driving.

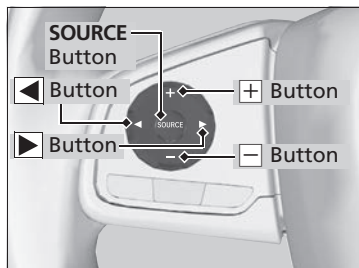

SOURCE Button

Cycles through the audio modes as follows:
FM→AM→USB/iPod→*Bluetooth*® Audio→
AUX

+ - (Volume) Buttons

Press +: To increase the volume.

Press -: To decrease the volume.

◀ ▶ Buttons

- When listening to the radio

Press ▶: To select the next preset radio station.

Press ◀: To select the previous preset radio station.

Press and hold ▶: To select the next strong station.

Press and hold ◀: To select the previous strong station.

- When listening to an iPod, USB flash drive, or *Bluetooth*® Audio

Press ▶: To skip to the next song.

Press ◀: To go back to the beginning of the current or previous song.

- When listening to a USB flash drive

Press and hold ▶: To skip to the next folder.



Press and hold ◀: To go back to the previous folder.

Audio Remote Controls

Some mode appears only when an appropriate device or medium is used.

Depending on the *Bluetooth*® device you connect, some functions may not be operated.

Audio System Basic Operation*

To use the audio system function, the ignition switch must be in ACCESSORY *1 or ON *1.

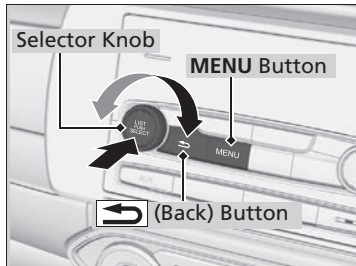

Use the selector knob or **MENU** button to access some audio functions.

LIST/SELECT (Selector) knob: Rotate left or right to scroll through the available choices.

Press  to set your selection.

Press  to switch between the normal and extended display for some functions.

MENU button: Press to display the available modes.

The available mode includes the auto select, save preset, *Bluetooth*[®] setup, and play modes. Play modes can be also selected from scan, random, repeat, and so on.

 **(Back) button:** Press to go back to the previous display.

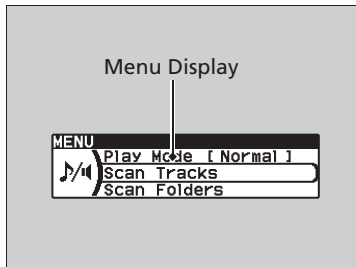







Audio System Basic Operation*





These indications are used to show how to operate the selector knob.

Rotate  to select.

Press  to enter.

Audio Menu Items

-  **Play Mode** P. 160, 163
-  **Scan** P. 157, 164
-  **Auto Select** P. 156
-  **Save Preset** P. 156
-  **Play/Pause** P. 160
-  **Resume/Pause** P. 166

Press the **SOURCE**, , ,  or  button on the steering wheel to change any audio setting.

-  **Audio Remote Controls** P. 152

*1: Models with the keyless access system have an **ENGINE START/STOP** button instead of an ignition switch.

* Not available on all models

Adjusting the Sound

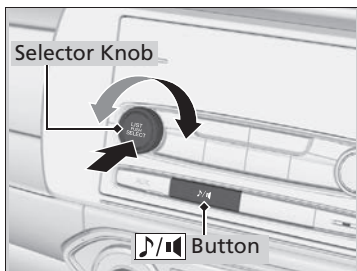

1. Press the button.
2. Rotate to select the sound mode, then press .
- ▶ Rotate to scroll through the following choices:

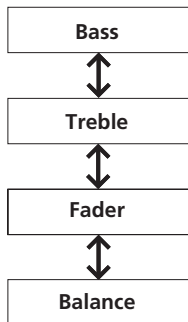
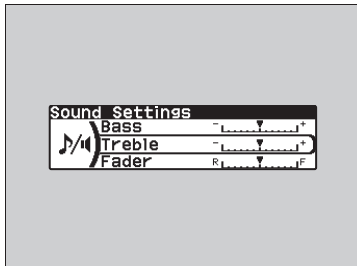

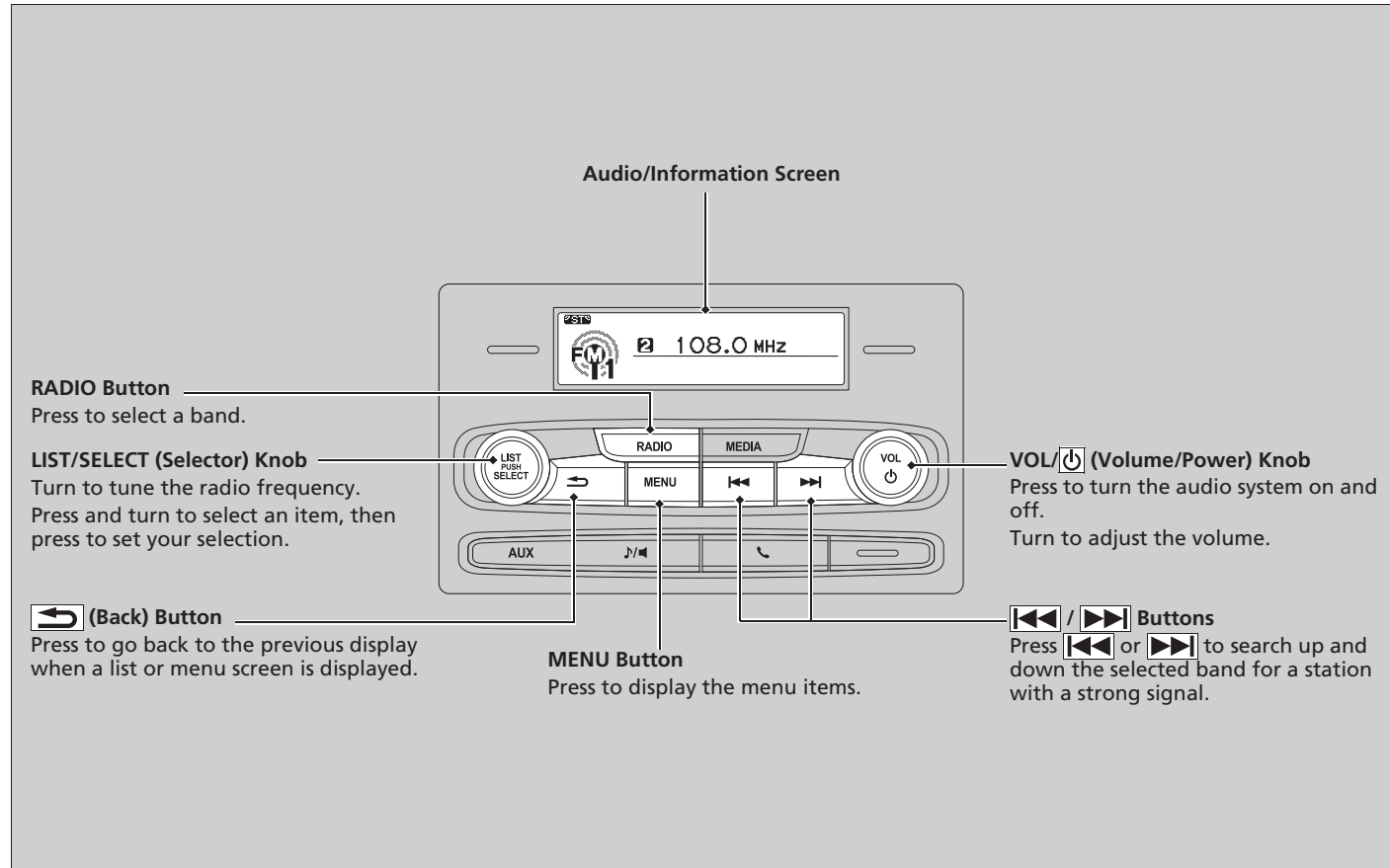

3. Rotate to adjust the level, then press .

Playing the AM/FM Radio



■ Auto Select





Use the auto select feature to scan both bands and store the strongest station in each preset.

1. Press the **MENU** button.
2. Rotate  to select **Auto Select**, then press .
 - ▶ The system goes into scan mode for several seconds.



To turn off auto select, press the **MENU** button and rotate  to select **Auto Select**, then press .

■ Preset Memory

Uses the preset memory feature to store a station in each preset.

1. Tune to the selected station.
2. Press the **MENU** button.
3. Rotate  to select **Save Preset**, then press .
4. Rotate  to select the preset number you want to store that station, then press .

You can also store that station by the following procedure.

1. Tune to the selected station.
2. Press  to switch to the preset list mode.
3. Rotate  to select a preset number, then press and hold .

▶▶ Playing the AM/FM Radio



The **ST** indicator appears on the display indicating stereo FM broadcasts.
Stereo reproduction in AM is not available.

You can store 6 AM stations and 12 FM stations into the preset memory.
Auto Select function scans and stores up to 6 AM stations and 12 FM stations with a strong signal into the preset memory.

If you do not like the stations auto select has stored, you can manually store your preferred frequencies.

■ Preset List

Lists the preset stations on the selected band.

1. Tune to the selected station.
2. Press  to switch to the preset list mode.
3. Rotate  to select a preset station, then press .

■ Scan

Samples each of the strongest stations on the selected band for 10 seconds.

1. Press the **MENU** button.
2. Rotate  to select **Scan**, then press .

To turn off scan, press .

Playing an iPod

Using your lightning connector, connect the iPod to a USB port, then press the **MEDIA** button.

📌 **USB Port** P. 149

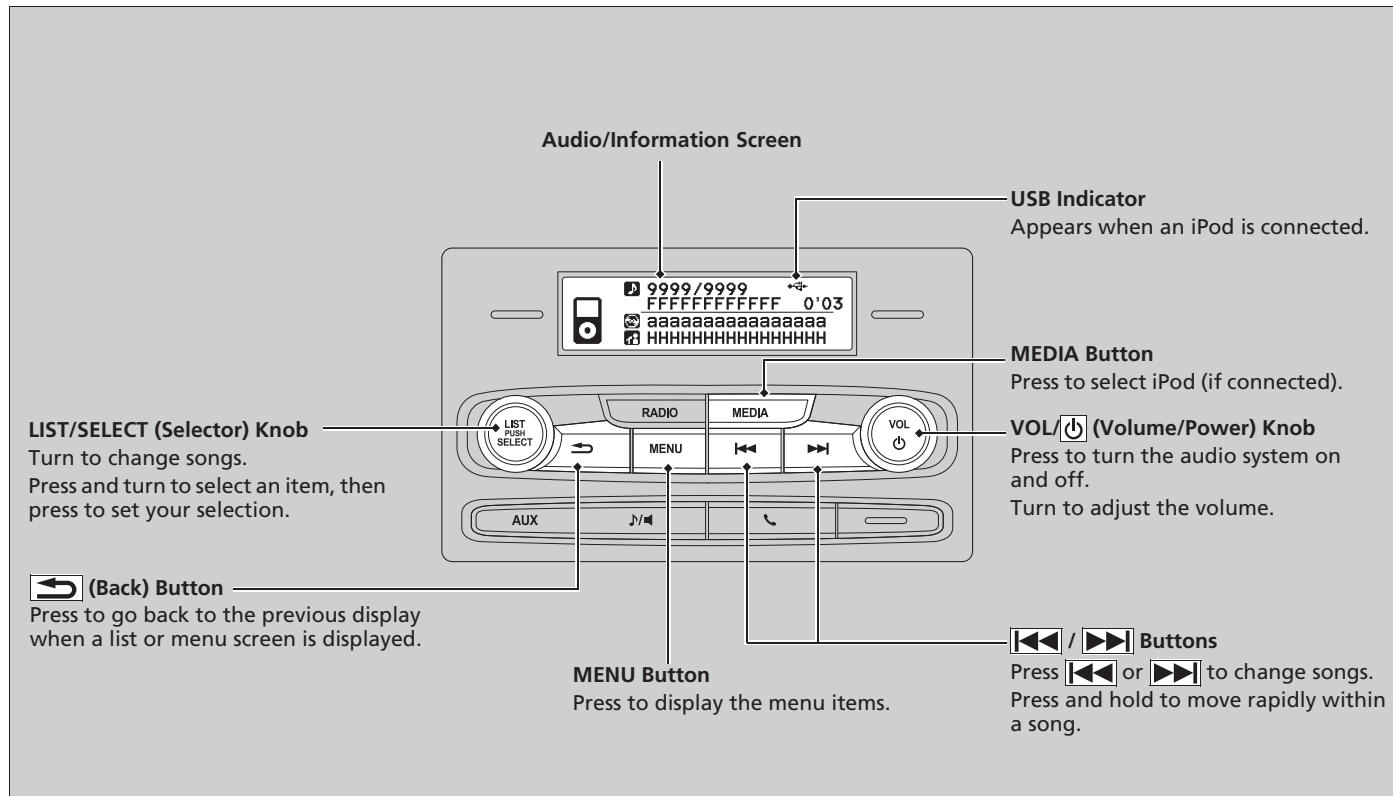

How to Select a Song from the iPod Music List with the Selector Knob

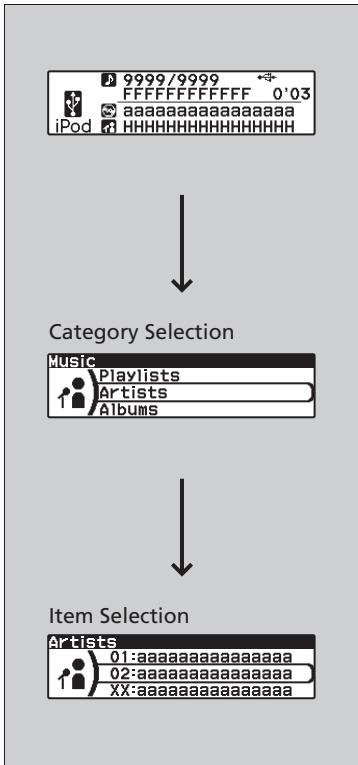

1. Press to display an iPod music list.

2. Rotate to select a category.

3. Press to display a list of items in the category.
4. Rotate to select an item, then press .
 - ▶ Repeat this procedure until a desired item you want to listen is displayed.

▶▶ Playing an iPod

Operating functions vary depending on the model or version of the iPod or iPhone used. Some functions may not be available on the vehicle's audio system.

If there is a problem, you may see an error message on the audio/information screen.

iPod/USB Flash Drive P. 167

Features

Continued

■ How to Select a Play Mode

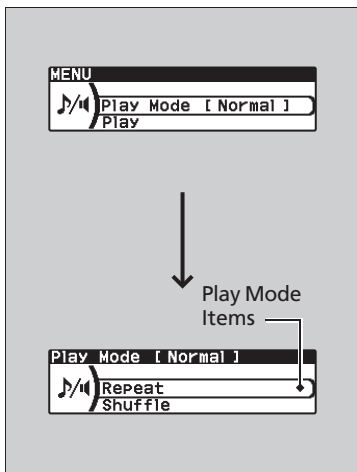

You can select repeat and shuffle modes when playing a file.

1. Press the **MENU** button.
2. Rotate to select **Play Mode**, then press .
3. Rotate to select a mode, then press .

■ To turn off a play mode

1. Press the **MENU** button, then press .
2. Rotate to select **Play Mode**, then press .
3. Rotate to select a mode to turn off, then press repeatedly until the mode indicator disappears.

■ To Pause or Play a Song

1. Press the **MENU** button.
2. Rotate to select **Pause** or **Play**, then press .

▶ How to Select a Play Mode

Play Mode Menu Items

Repeat: Cycles through the repeat options.

When the repeat mode is turned on, you will see the following mode indicators in the display:

: Repeats all songs in the current list (playlists, artists, albums, songs, genres, or composers).

: Repeats the current song.

Shuffle: Cycles through the shuffle options.

When the shuffle mode is turned on, you will see the following mode indicators in the display:

: Plays all available songs in a selected list (playlists, artists, albums, songs, genres, or composers) in random order.

: Plays all available albums in a selected list (playlists, artists, albums, songs, genres, or composers) in random order.

When repeat and shuffle modes are turned off, you will see **Normal** in the display.

Playing a USB Flash Drive

Your audio system reads and plays sound files on a USB flash drive in either MP3, WMA or AAC*1 format.

Connect your USB flash drive to the USB port, then press the **MEDIA** button.

➤ **USB Port** P. 149

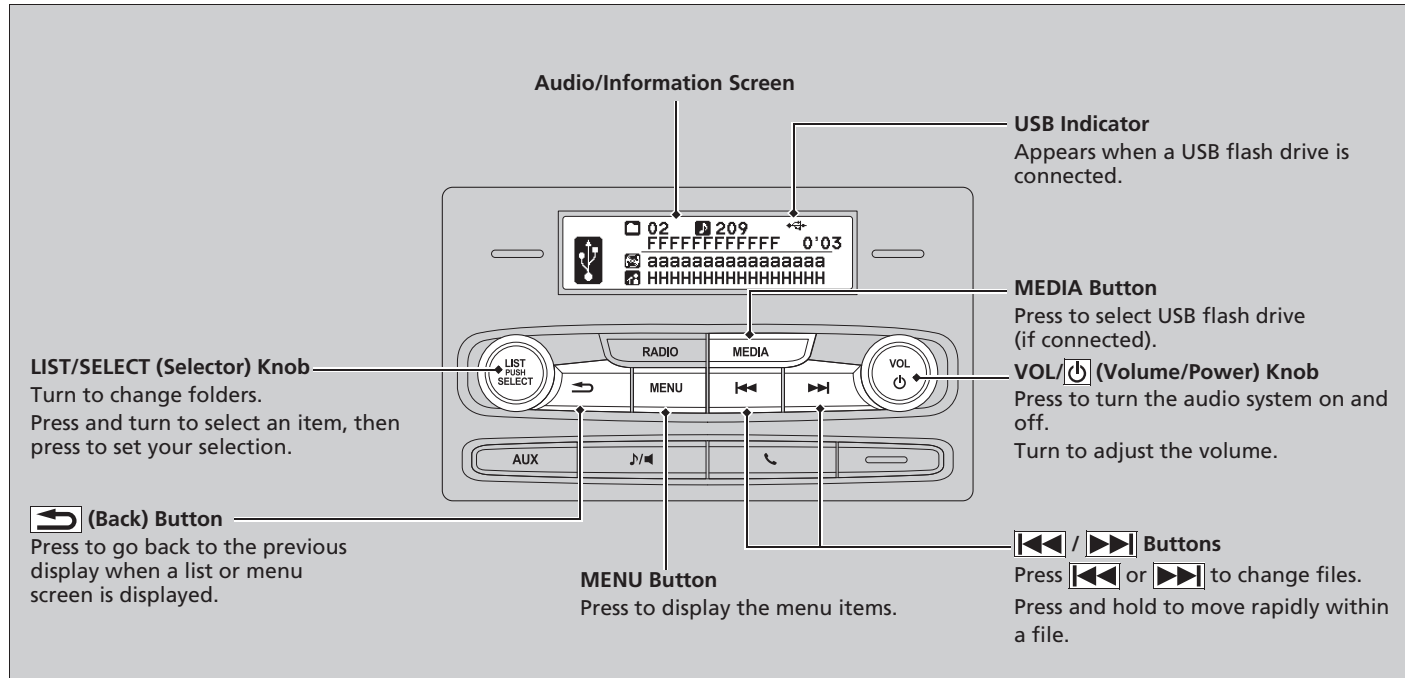

*1: Only AAC format files recorded with iTunes are playable on this unit.

How to Select a File from a Folder with the Selector Knob

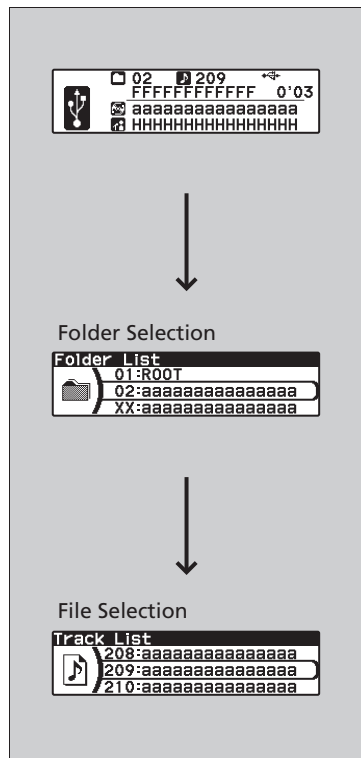

1. Press to display a folder list.

2. Rotate to select a folder.

3. Press to change the display to a list of files in that folder.

4. Rotate to select a file, then press .

Playing a USB Flash Drive

Use the recommended USB flash drives.

General Information on the Audio System*
P. 168

Files in WMA format protected by digital rights management (DRM) cannot be played. The audio system displays **UNPLAYABLE FILE**, and then skips to the next file.

If there is a problem, you may see an error message on the audio/information screen.

iPod/USB Flash Drive P. 167

How to Select a Play Mode

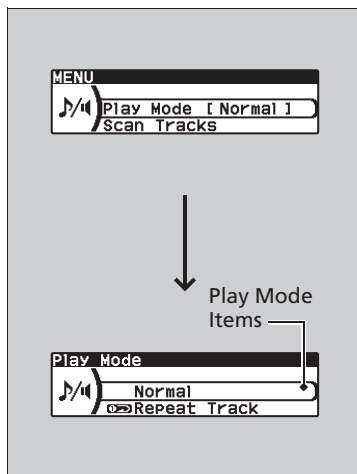

You can select repeat and random modes when playing a file.

1. Press the **MENU** button.
2. Rotate to select **Play Mode**, then press .
3. Rotate to select a mode, then press .

■ To turn off a play mode

1. Press the **MENU** button.
2. Rotate to select **Play Mode**, then press .
3. Rotate to select **Normal**, then press .

How to Select a Play Mode

Play Mode Menu Items

Normal

Repeat Track: Repeats the current file.

Repeat Folder: Repeats all files in the current folder.

Random in Folder: Plays all files in the current folder in random order.

Random All: Plays all files in random order.

■ Scan

You can select scan modes when playing a file.

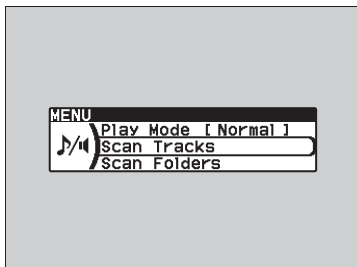

1. Press the **MENU** button.
2. Rotate  to select **Scan Tracks** or **Scan Folders**, then press .

To turn off scan, press .

▣ Scan

Scan mode menu items

Scan Tracks: Provides 10-second sampling of all files in the folder.

Scan Folders: Provides 10-second sampling of the first file in each of the main folders.

Playing *Bluetooth*® Audio

Your audio system allows you to listen to music from your *Bluetooth*®-compatible phone.

This function is available when the phone is paired and connected to the vehicle's Hands-Free Telephone (HFT) system.

☛ **Phone Setup** P. 175

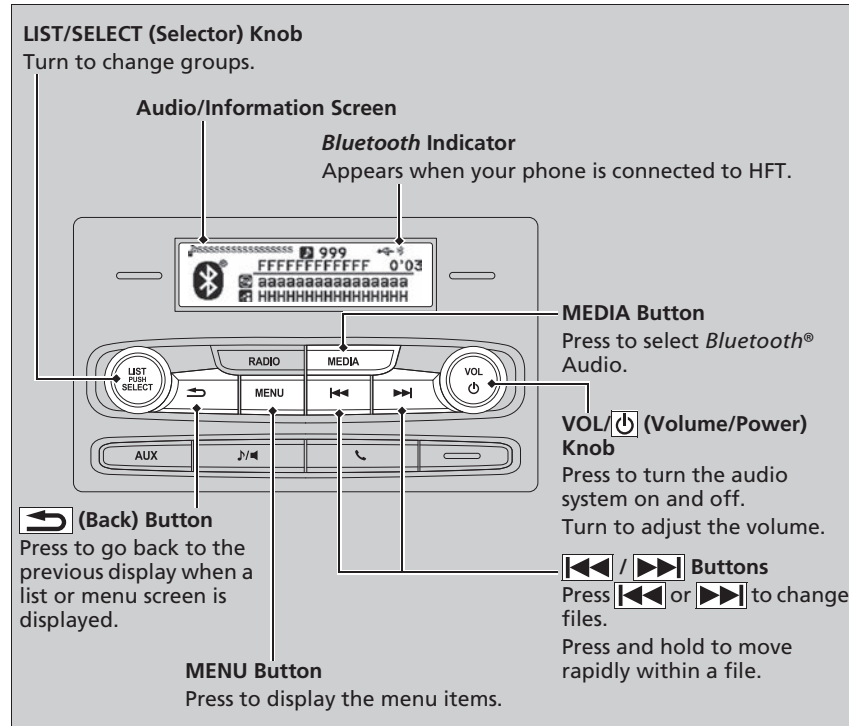

▶▶ Playing *Bluetooth*® Audio

Not all *Bluetooth*-enabled phones with streaming audio capabilities are compatible with the system. To check if your phone is compatible, ask a dealer.

In some countries, it may be illegal to perform some data device functions while driving.

If more than one phone is paired to the HFT system, there will be a delay before the system begins to play.

In some cases, the name of the artist, album, or track may not appear correctly.

Some functions may not be available on some devices.

Continued

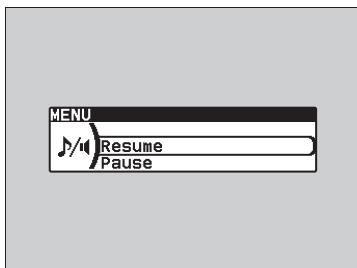

■ To Play *Bluetooth*® Audio Files



1. Make sure that your phone is paired and connected to the system.
2. Press the **MEDIA** button.

If the phone is not recognised, another HFT-compatible phone, which is not compatible for *Bluetooth*® Audio, may already be connected.

■ To pause or resume a file

1. Press the **MENU** button.
2. Rotate  to select **Pause** or **Resume**, then press .

☒ To Play *Bluetooth*® Audio Files

To play the audio files, you may need to operate your phone. If so, follow the phone maker's operating instructions.

The pause function may not be available on some phones.

If any audio device is connected to the auxiliary input jack or USB port, you may need to press the **MEDIA** button repeatedly to select the *Bluetooth*® Audio system.

Switching to another mode pauses the music playing from your phone.

Audio Error Messages*

iPod/USB Flash Drive

If an error occurs while playing an iPod or USB flash drive, you may see the following error messages. If you cannot clear the error message, contact a dealer.

Error Message	Solution
Bad USB Device Please Check Owner's Manual	Appears when an incompatible device is connected. Disconnect the device. Then turn the audio system off, and turn it on again. Do not reconnect the device that caused the error.
UNSUPPORTED	Appears when an unsupported device is connected. If it appears when a supported device is connected, reconnect the device. Appears when unsupported formats are in the device. Check that compatible files are stored on the device.
NO RESPONSE	Appears when the system does not communicate with a connected device. If it appears when a device is connected, contact your place of device purchase.
USB HUB ERROR	Appears when only a HUB is connected. If it appears, connect a USB flash drive to the HUB.
NO DATA	iPod Appears when the iPod is empty. USB flash drive Appears when the USB flash drive is empty or there are no MP3, WMA, or AAC files in the USB flash drive. iPod and USB flash drive Check that compatible files are stored on the device.
UNPLAYABLE FILE	Appears when the files in the USB flash drive are DRM or an unsupported format. This error message appears for about 3 seconds, then plays the next song.
UNSUPPORTED VER.	Appears when an unsupported iPod is connected. If it appears when a supported iPod is connected, update the iPod software to the newer version.
CONNECT RETRY	Appears when the system does not acknowledge the iPod. Reconnect the iPod.

* Not available on all models

General Information on the Audio System*

Compatible iPod, iPhone, and USB Flash Drives

iPod Model Compatibility

Model
iPod touch (5th/6th generation)
iPod nano (7th generation)
iPhone 5/iPhone 5c/iPhone 5s/iPhone 6/iPhone 6 Plus/ iPhone 6s/iPhone 6s Plus/iPhone SE/iPhone 7/iPhone 7 Plus

USB Flash Drives

- A USB flash drive of 256 MB or higher is recommended.
- Some digital audio players may not be compatible.
- Some USB flash drives (e.g., a device with security lockout) may not work.
- Some software files may not allow for audio play or text data display.
- Some versions of MP3, WMA, or AAC formats may be unsupported.

iPod Model Compatibility

This system may not work with all software versions of these devices.

USB Flash Drives

Files on the USB flash drive are played in their stored order. This order may be different from the order displayed on your PC or device.

Hands-Free Telephone System*

Hands-Free Telephone (HFT) System allows you to place and receive phone calls using your vehicle's audio system, without handling your mobile phone.

Using HFT

HFT Buttons

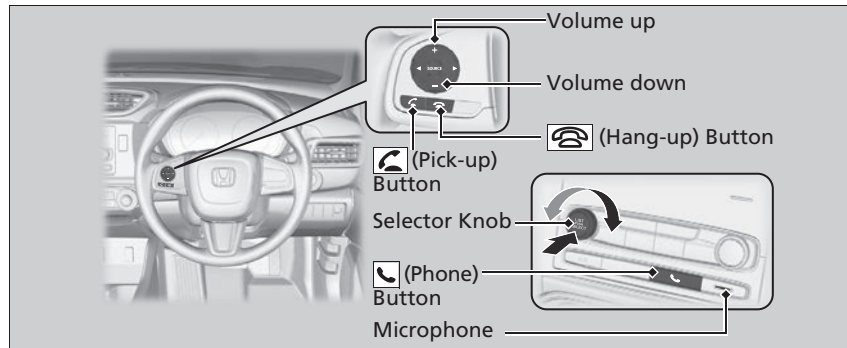

(Pick-up) button: Press to go to the **Phone** screen, or to answer an incoming call.

(Hang-up) button: Press to end a call.

(Phone) button: Press to go to the **Phone** screen, or to answer an incoming call or end a call.

LIST/SELECT (Selector) knob: Rotate left or right to scroll through the available choices. Press  to set your selection.

* Not available on all models

Hands-Free Telephone System*

Place your phone where you can get good reception.

To use HFT, you need a *Bluetooth*-compatible mobile phone. For a list of compatible phones, pairing procedures, and special feature capabilities, ask a dealer or your local Honda.

Up to 15 speed dial entries can be stored.

 **Speed Dial** P. 184

Up to 15 call histories can be stored.

To change the volume level, use the audio system's volume knob or the remote audio controls on the steering wheel.

If you receive a call while using the audio system, the system resumes its operation after ending the call.

Continued

HFT Status Display

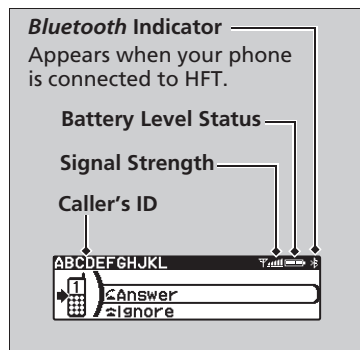

The display notifies you when there is an incoming call.

Hands-Free Telephone System*

Bluetooth® Wireless Technology

The *Bluetooth*® word mark and logos are registered trademarks owned by Bluetooth SIG, Inc., and any use of such marks by Honda Motor Co., Ltd., is under licence. Other trademarks and trade names are those of their respective owners.

HFT Limitations

An incoming call on HFT will interrupt the audio system when it is playing. It will resume when the call is ended.

HFT Status Display

The information that appears on the display varies between phone models.

HFT Menu

The ignition switch must be in ACCESSORY **I***2 or ON **II***2 to use HFT.

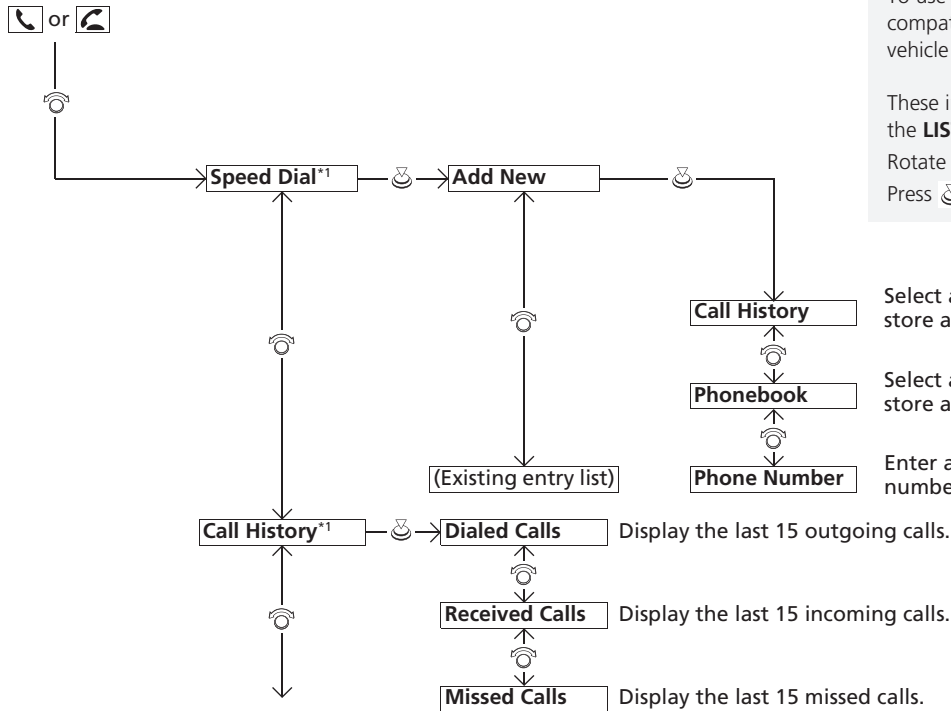

▶▶ HFT Menu

To use HFT, you must first pair your *Bluetooth*-compatible mobile phone to the system while the vehicle is parked.

These indications are used to show how to operate the **LIST/SELECT** (selector) knob.

Rotate to select.

Press to enter.

Select a phone number from the call history to store as a speed dial number.

Select a phone number from the phonebook to store as a speed dial number.

Enter a phone number to store as a speed dial number.

Display the last 15 outgoing calls.

Display the last 15 incoming calls.

Display the last 15 missed calls.

*1: Appears only when a phone is connected to the system.

*2: Models with the keyless access system have an **ENGINE START/STOP** button instead of an ignition switch.

Continued

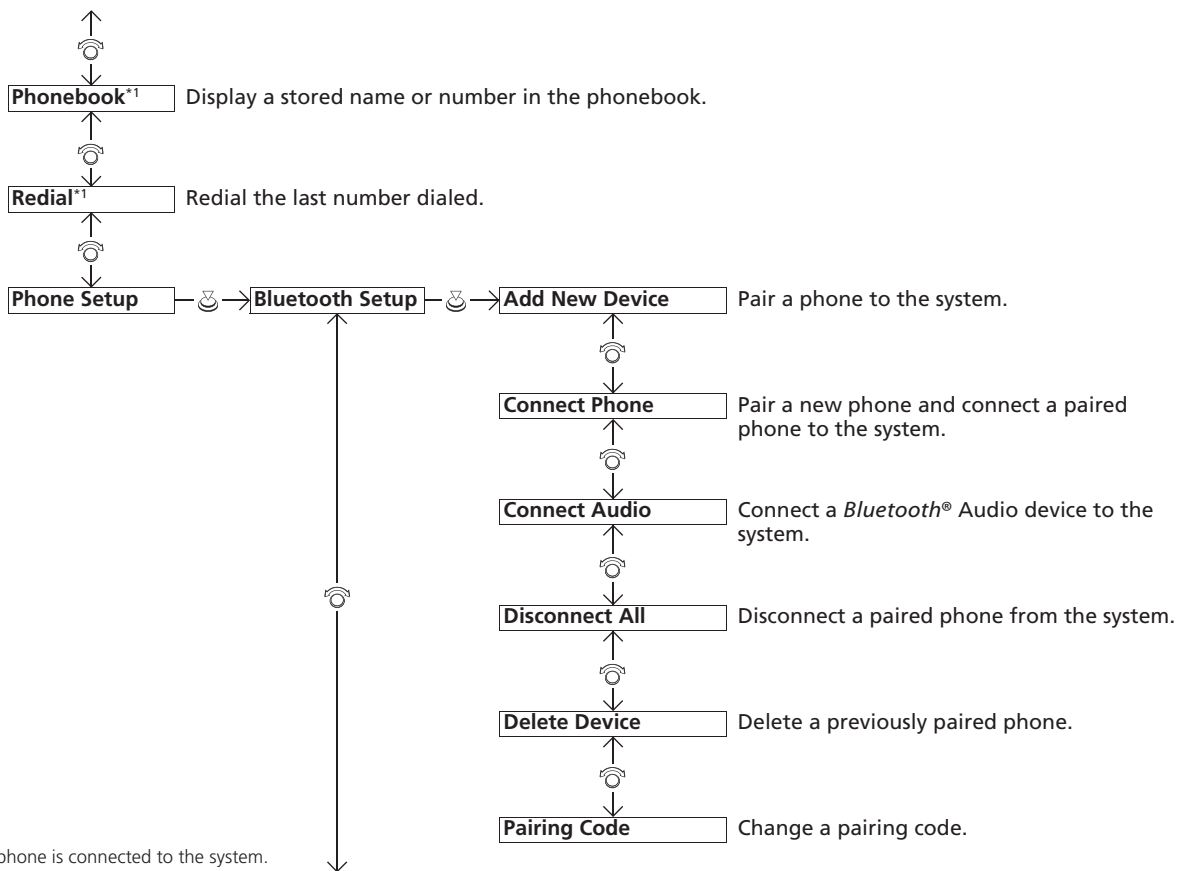

*1: Appears only when a phone is connected to the system.

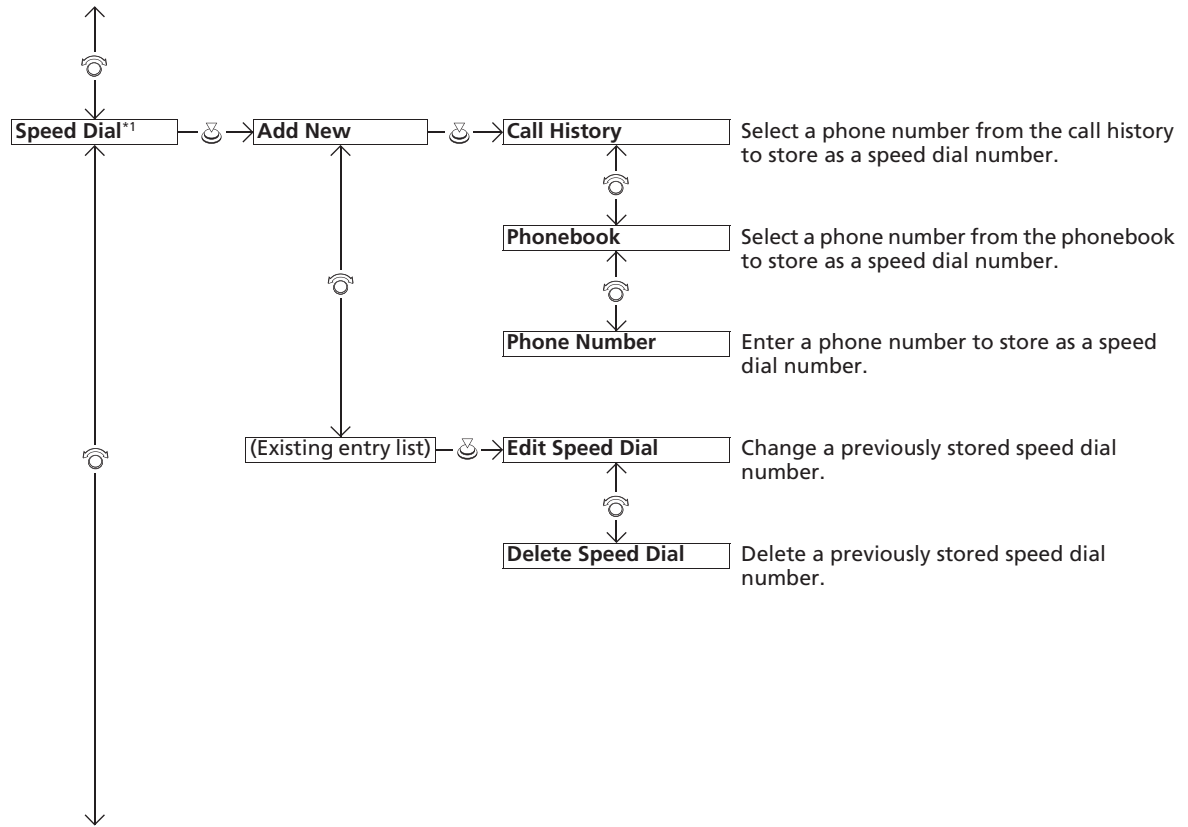



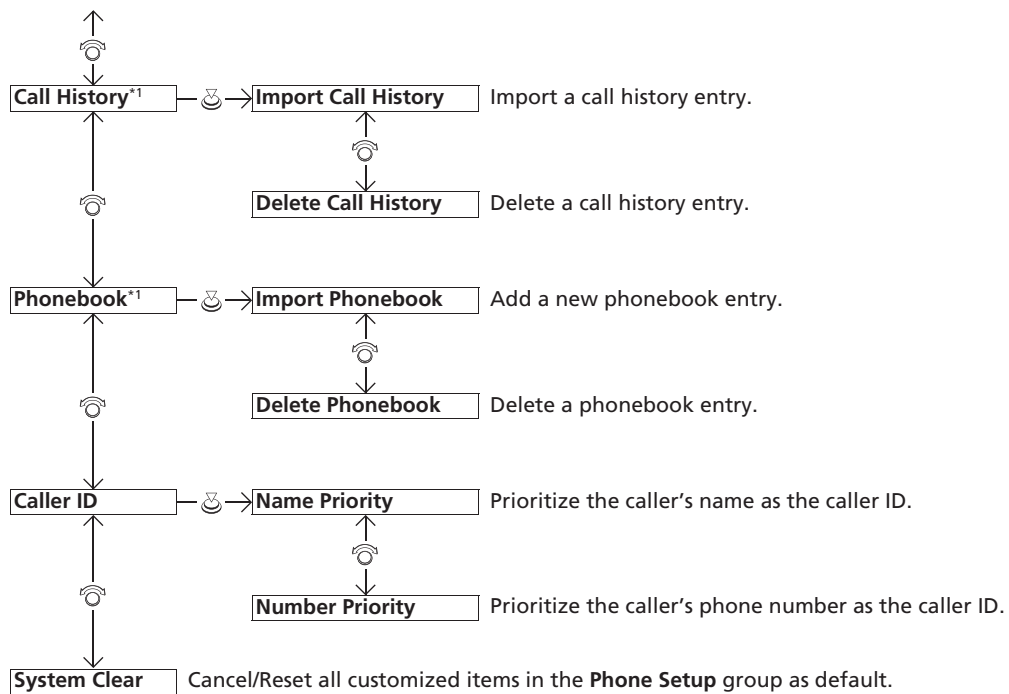

*1: Appears only when a phone is connected to the system.



*1: Appears only when a phone is connected to the system.

Phone Setup

■ To pair a mobile phone from the system (No phone has been paired to the system)

1. Press the  (Phone) button or the  (Pick-up) button.
2. Rotate  to select **Yes**, then press .
3. Make sure your phone is in search or discoverable mode, then press .
 - ▶ HFT automatically searches for a *Bluetooth* device.
4. The system gives you a pairing code on your phone.
When your phone prompts you, input the pairing code.

☒ Phone Setup

Your *Bluetooth*-compatible phone must be paired to the system before you can make and receive hands-free calls.

Phone Pairing Tips:

- You cannot pair your phone while the vehicle is moving.
- Up to five phones can be connected.
- Your phone's battery may drain faster when it is paired to the system.

Continued

■ To pair a mobile phone (when a phone has already been paired to the system)

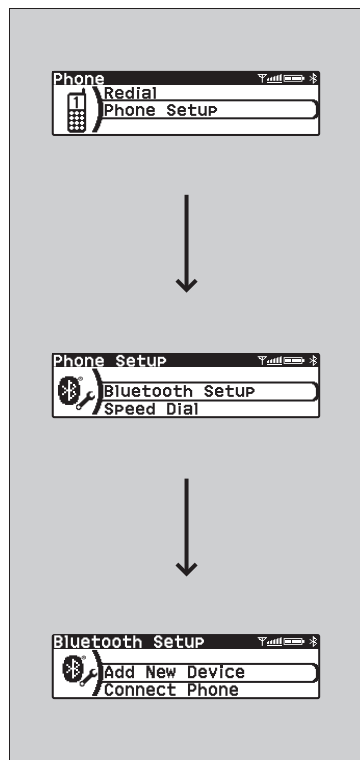







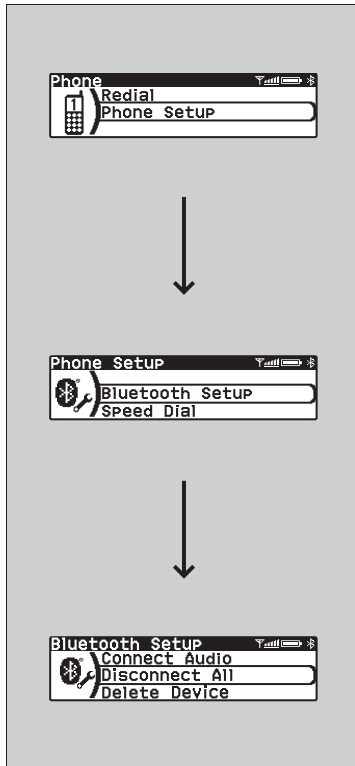

1. Press the (Phone) button or the (Pick-up) button.
 - ▶ If a prompt appears asking to connect to a phone, select **No** and proceed with step 2.
2. Rotate to select **Phone Setup**, then press .
3. Rotate to select **Bluetooth Setup**, then press .
4. Rotate to select **Add New Device**, then press .
5. Make sure your phone is in search mode, then press .
6. The system gives you a pairing code on your phone.
When your phone prompts you, input the pairing code.

Features

■ To disconnect the paired phone



1. Press the  (Phone) button or the  (Pick-up) button.
2. Rotate  to select **Phone Setup**, then press .
3. Rotate  to select **Bluetooth Setup**, then press .
4. Rotate  to select **Disconnect All**, then press .
5. A confirmation message appears on the screen. Rotate  to select **Yes**, then press .

Continued

■ To change the currently paired phone

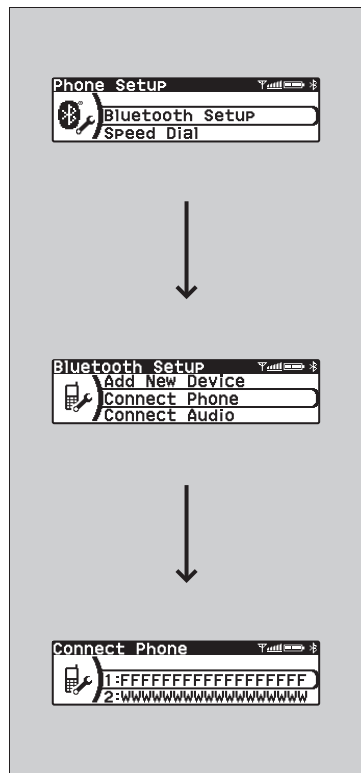

1. Press the (Phone) button or the (Pick-up) button.
2. Rotate to select **Phone Setup**, then press .
3. Rotate to select **Bluetooth Setup**, then press .
4. Rotate to select **Connect Phone**, then press .
▶ The screen changes to a device list.
5. Rotate to select a desired device name, then press .

■ To change the pairing code setting

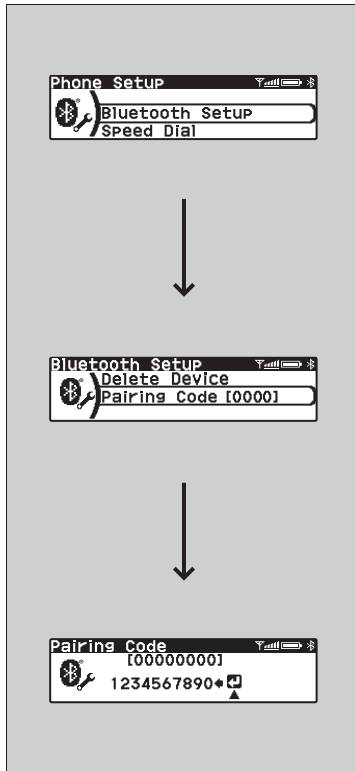

1. Press the (Phone) button or the (Pick-up) button.
2. Rotate to select **Phone Setup**, then press .
3. Rotate to select **Bluetooth Setup**, then press .
4. Rotate to select **Pairing Code**, then press .
5. Input a new pairing code, then press .

Continued

■ To delete a paired phone

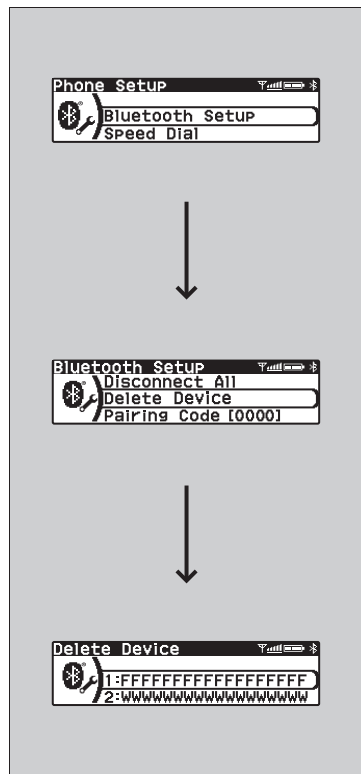

1. Press the (Phone) button or the (Pick-up) button.
2. Rotate to select **Phone Setup**, then press .
3. Rotate to select **Bluetooth Setup**, then press .
4. Rotate to select **Delete Device**, then press .
▶ The screen changes to a device list.
5. Rotate to select a phone you want to delete, then press .
6. A confirmation message appears on the screen. Rotate to select **Yes**, then press .

■ Caller's ID Information

You can select a caller's information to be displayed when you have an incoming call.

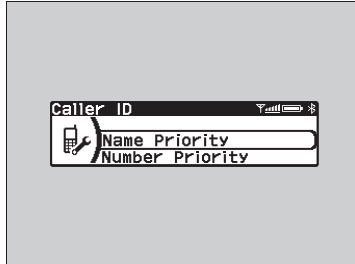

1. Press the (Phone) button or the (Pick-up) button.
2. Rotate to select **Phone Setup**, then press .
3. Rotate to select **Caller ID**, then press .
4. Rotate to select a mode you want, then press .

■ To Clear the System

Pairing codes, paired phones, all speed dial entries, all call history data, and all imported phonebook data are erased.

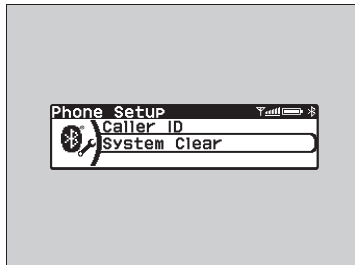

1. Press the (Phone) button or the (Pick-up) button.
2. Rotate to select **Phone Setup**, then press .
3. Rotate to select **System Clear**, then press .
4. Rotate to select **Yes**, then press .
5. A notification appears on the screen. Press .

☒ Caller's ID Information

Name Priority: A caller's name is displayed if it is stored in the phonebook.

Number Priority: A caller's phone number is displayed.

Continued

Mobile Phonebook

When your phone is paired, the contents of its phonebook are automatically imported to the system.

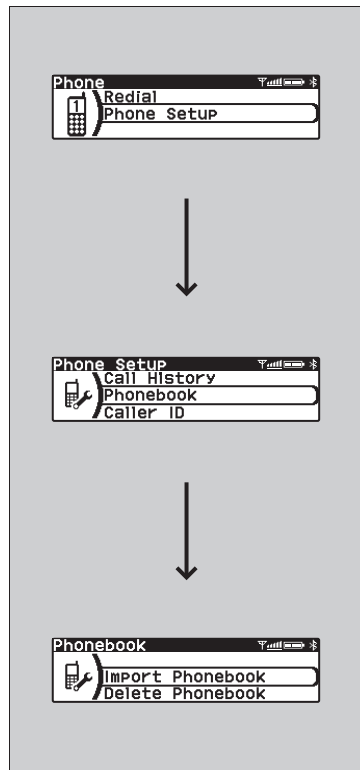

■ To manually import the phonebook data of the mobile phone

1. Press the (Phone) button or the (Pick-up) button.
2. Rotate to select **Phone Setup**, then press .
3. Rotate to select **Phonebook**, then press .
4. Rotate to select **Import Phonebook**, then press .
5. Rotate to select **Yes**, then press .
 - ▶ The system will begin importing the phonebook data.

■ To delete the imported phonebook data

1. Press the (Phone) button or the (Pick-up) button.
2. Rotate to select **Phone Setup**, then press .
3. Rotate to select **Phonebook**, then press .
4. Rotate to select **Delete Phonebook**, then press .
5. Rotate to select **Yes**, then press .

Mobile Phonebook

For a list of this feature capability, ask a dealer.

■ Call History

When your phone is paired, the contents of its call history have to be manually imported to the system.

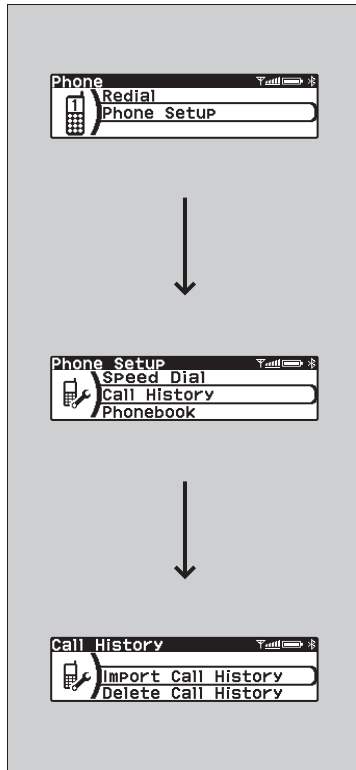

■ To import the call history data of the mobile phone

1. Press the (Phone) button or the (Pick-up) button.
2. Rotate to select **Phone Setup**, then press .
3. Rotate to select **Call History**, then press .
4. Rotate to select **Import Call History**, then press .
5. Rotate to select **Yes**, then press .
 - ▶ The system will begin importing the call history data.

■ To delete the imported call history data

1. Press the (Phone) button or the (Pick-up) button.
2. Rotate to select **Phone Setup**, then press .
3. Rotate to select **Call History**, then press .
4. Rotate to select **Delete Call History**, then press .
5. Rotate to select **Yes**, then press .

▣ Call History





For a list of this feature capability, ask a dealer.

Continued

■ Speed Dial

Up to 15 speed dial numbers can be stored per phone.

To store a speed dial number:

1. Press the  (Phone) button or the  (Pick-up) button.
2. Rotate  to select **Speed Dial**, then press .
 - ▶ The screen changes to a speed dial list.

3. Rotate  to select **Add New**, then press .

From **Call History**:

- ▶ Select a number from the call history.

From **Phonebook**:







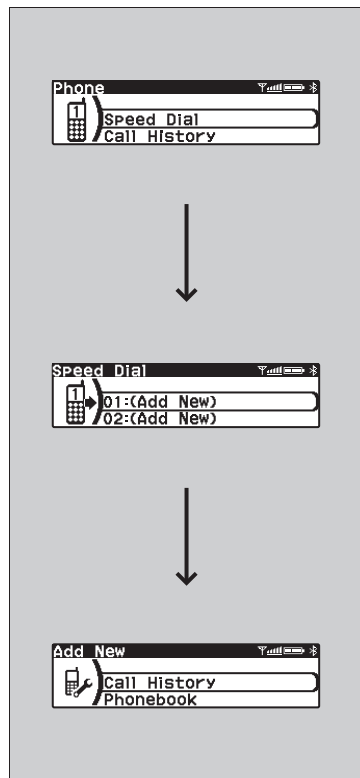

- ▶ Select a number from the connected mobile phone's imported phonebook.

From **Phone Number**:











- ▶ Input the number manually.



■ To edit a speed dial

1. Press the  (Phone) button or the  (Pick-up) button.
2. Rotate  to select **Phone Setup**, then press .
3. Rotate  to select **Speed Dial**, then press .
4. Select an existing speed dial entry, then press .
5. Rotate  to select **Edit Speed Dial**, then press .
 - From **Call History**:
 - ▶ Select a number from the call history.
 - From **Phonebook**:
 - ▶ Select a number from the connected mobile phone's imported phonebook.
 - From **Phone Number**:
 - ▶ Input the number manually.

■ To delete a speed dial

1. Press the  (Phone) button or the  (Pick-up) button.
2. Rotate  to select **Phone Setup**, then press .
3. Rotate  to select **Speed Dial**, then press .
4. Select an existing speed dial entry, then press .
5. Rotate  to select **Delete Speed Dial**, then press .
6. A confirmation message appears on the screen. Rotate  to select **Yes**, then press .

■ Making a Call

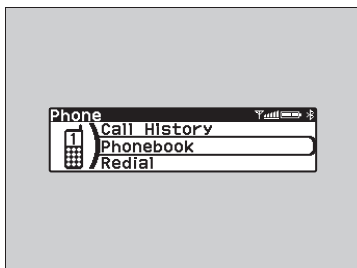

You can make calls by using the following:





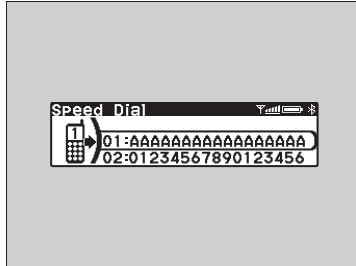

- Speed Dial
- Call History
- Phonebook
- Redial

☒ Making a Call

Once a call is connected, you can hear the voice of the person you are calling through the audio speakers.

■ To make a call using a speed dial entry





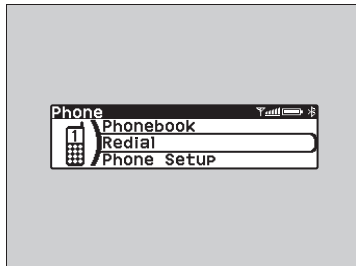

1. Press the  (Phone) button or the  (Pick-up) button.
2. Rotate  to select **Speed Dial**, then press .
3. Rotate  to select a number, then press .
 - ▶ Dialing starts automatically.

■ To make a call using redial

The latest dialed call can be redialed.



1. Press the  (Phone) button or the  (Pick-up) button.
2. Rotate  to select **Redial**, then press .
 - ▶ Dialing starts automatically.

■ To make a call using the call history

The call history is stored by **Dialed Calls**, **Received Calls**, and **Missed Calls**.

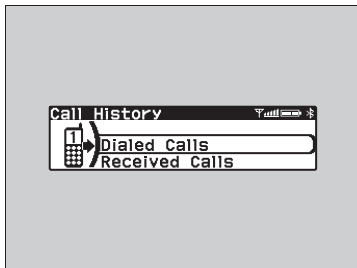

1. Press the (Phone) button or the (Pick-up) button.
2. Rotate to select **Call History**, then press .
3. Rotate to select **Dialed Calls**, **Received Calls**, or **Missed Calls**, then press .
 - ▶ The screen changes to each list.
4. Rotate to select a number, then press .
 - ▶ Dialing starts automatically.

■ To make a call using the phonebook

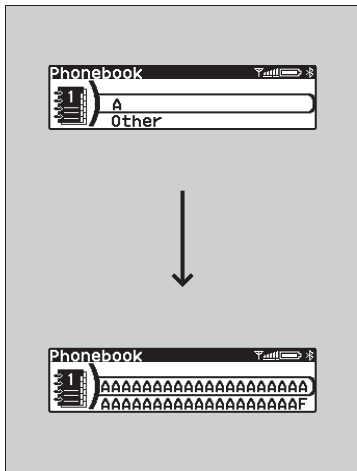

1. Press the (Phone) button or the (Pick-up) button.
2. Rotate to select **Phonebook**, then press .
 - ▶ The phonebook is stored alphabetically.
3. Rotate to select the first letter of a name on the list, then press .
4. Rotate to select the name on the list, then press .
5. Rotate to select a number on the list, then press .
 - ▶ Dialing starts automatically.

▶ To make a call using the call history

The call history appears only when a phone is connected to the system, and displays the last 15 dialed, received, or missed calls.





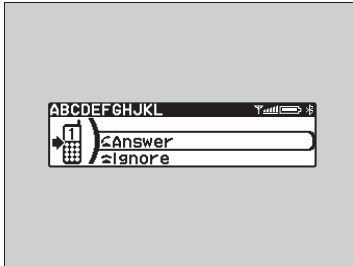

▶ To make a call using the phonebook

When your phone is paired, the contents of its phonebook can be imported to the system.

■ Receiving a Call







When there is an incoming call, an audible notification sounds and the Incoming Call screen appears.



Press the  (Phone) button or the  (Pick-up) button to answer the call.
 Press and hold the  (Phone) button or press the  (Hang-Up) button to decline the call.
 Press the  (Phone) button or the  (Hang-Up) button to end the call.





▶ Receiving a Call

Call Waiting

Press the  (Phone) button or the  (Pick-up) button to put the current call on hold to answer the incoming call.

Press the  (Phone) button or the  (Pick-up) button again to end the call and return to the current call.

Press and hold the  (Phone) button or press the  (Hang-Up) button to ignore the incoming call if you do not want to answer it.

You can select the options on the audio/information screen instead of using ,  and  buttons. Rotate  to select the option, then press .

Continued

■ Options During a Call

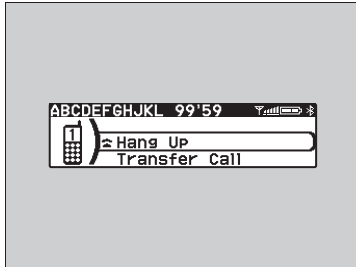

The following operations are available during a call.



Hang Up: End the call.

Transfer Call: Transfer a call from the system to your phone.

Mute: Mute your voice.

Rotate  to select the option, then press .

- ▶ Select **Mute** to turn on, then select **Mute** again to turn it off.

Driving

This chapter discusses driving and refueling.

Before Driving	
Driving Preparation	192
Load Limit	195
Towing a Trailer	196
When Driving	
Models without keyless access system	
Starting the Engine	197
Models with keyless access system	
Starting the Engine	199
Precautions While Driving.....	202
Continuously Variable Transmission* ...	204

Continuously variable transmission models without paddle shifters

Shifting.....	205
---------------	-----

Continuously variable transmission models with paddle shifters

Shifting.....	208
---------------	-----

Manual transmission models

Shifting.....	212
Cruise Control*	214

Braking

Brake System	217
Anti-lock Brake System (ABS)	219

Parking Your Vehicle

When Stopped	220
Parking Sensor System	222

Refueling

Petrol models

Fuel Information	224
------------------------	-----

Diesel models

Fuel Information	225
How to Refuel	226

Fuel Economy and CO₂ Emissions

Improving Fuel Economy and Reducing CO ₂ Emissions	228
---	-----

* Not available on all models

Before Driving

Driving Preparation

Check the following items before you start driving.

Exterior Checks

- Make sure there are no obstructions on the windows, door mirrors, exterior lights, or other parts of the vehicle.
 - ▶ Remove any frost, snow, or ice.
 - ▶ Remove any snow on the roof, as this can slip down and obstruct your field of vision while driving. If frozen solid, remove ice once it has softened.
 - ▶ When removing ice from around the wheels, be sure not to damage the wheel or wheel components.
- Make sure the bonnet is securely closed.
 - ▶ If the bonnet opens while driving, your front view will be blocked.
- Make sure the tyres are in good condition.
 - ▶ Check air pressures, and check for damage and excessive wear.
 - **Checking and Maintaining Tyres** P. 268
- Make sure there are no people or objects behind or around the vehicle.
 - ▶ There are blind spots from the inside.

Exterior Checks

NOTICE

When doors are frozen shut, use warm water around the door edges to melt any ice. Do not try to force them open, as this can damage the rubber trim around the doors. When done, wipe dry to avoid further freezing.

Do not pour warm water into the key cylinder. You will be unable to insert the key if the water freezes in the hole.

Heat from the engine and exhaust can ignite flammable materials left under the bonnet, causing a fire. If you've parked your vehicle for an extended period, inspect and remove any debris that may have collected, such as dried grass and leaves that have fallen or have been carried in for use as a nest by a small animal. Also check under the bonnet for leftover flammable materials after you or someone else has performed maintenance on your vehicle.

Interior Checks

- Store or secure all items on board properly.
 - ▶ Carrying too much luggage, or improperly storing it, can affect your vehicle's handling, stability, stopping distance, and tyres, and make it unsafe.
 - **Load Limit** P. 195
- Do not pile items higher than the seat height.
 - ▶ They can block your view and may be thrown forward in the event of sudden braking.
- Do not place anything in the front seat footwells. Make sure to secure the floor mat.
 - ▶ An object or unsecured floor mat can interfere with your brake and accelerator pedal operation while driving.
- If you have any animals on board, do not let them move around in the vehicle.
 - ▶ They may interfere with driving and a crash could occur.
- Securely close all doors and the boot.
- Adjust your seating position properly.

Models with adjustable head restraint

- ▶ Adjust the head restraint, too.
 - **Adjusting the Seats** P. 126
 - **Adjusting the Front Head Restraints*** P. 129
- Adjust the mirrors and steering wheel* properly.
 - ▶ Adjust them while sitting in the proper driving position.
 - **Adjusting the Mirrors** P. 125
 - **Adjusting the Steering Wheel*** P. 124

* Not available on all models

Interior Checks

The headlight aim is set by the factory, and does not need to be adjusted. However, if you regularly carry heavy items in the boot, have the aiming readjusted at a dealer or by a qualified technician.

You can adjust the low beam headlight angle by your self.

➤ **Headlight Adjuster** P. 119

Continued

- Be sure items placed on the floor behind the front seats cannot roll under the seats.
 - ▶ They can interfere with the driver's ability to operate the pedals, or the operation of the seats.
- Everyone in the vehicle must fasten their seat belt.
 - ▶ **Fastening a Seat Belt** P. 34
- Make sure that the indicators in the instrument panel come on when you start the vehicle, and go off soon after.
 - ▶ Always have a dealer check the vehicle if a problem is indicated.
 - ▶ **Indicators** P. 72

Load Limit

When you load luggage, the total weight of the vehicle, all passengers, and luggage must not exceed the maximum permissible weight.

➤ **Specifications** P. 314, 316

» Load Limit

⚠ WARNING

Overloading or improper loading can affect handling and stability and cause a crash in which you can be hurt or killed.

Follow all load limits and other loading guidelines in this manual.

Towing a Trailer

Your vehicle is not designed to tow a trailer. Attempting to do so can void your warranties.

When Driving

Models without keyless access system

Starting the Engine

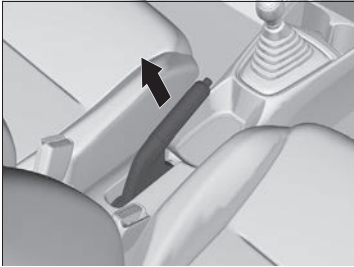

1. Make sure the parking brake is applied.

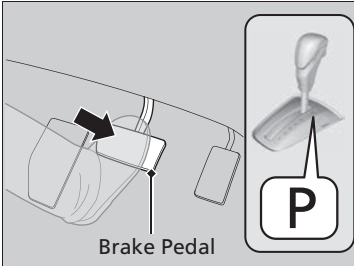

Continuously variable transmission models

2. Check that the transmission is in **P**, then depress the brake pedal.
 - ▶ Although it is possible to start the vehicle in **N**, it is safer to start it in **P**.

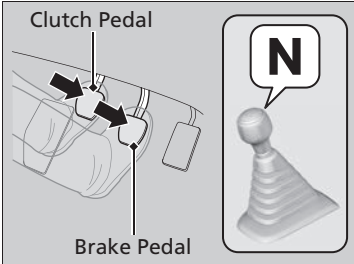

Manual transmission models

2. Check that the shift lever is in **N**. Then depress the brake pedal with your right foot, and the clutch pedal with your left foot.
 - ▶ The clutch pedal must be fully depressed to start the engine.

Starting the Engine

Keep your foot firmly on the brake pedal when starting the engine.

When starting the engine in cold weather, turn off all electrical accessories such as the lights, heating and cooling system in order to reduce battery drain.

If the exhaust system sounds abnormal or you can smell exhaust gas inside the vehicle, have your vehicle checked by a dealer. There may be a problem with the engine or exhaust system.

The immobilizer system protects your vehicle from theft. If an improperly coded device is used, the engine's fuel system is disabled.

▶ **Immobilizer System** P. 108

The engine is harder to start in cold weather and in thinner air found at altitudes above 2,400 metres.

Continued



Petrol models

3. Turn the ignition switch to START **III** without depressing the accelerator pedal.

Diesel models

3. Wait until the glow plugs indicator goes off, then turn the ignition switch to START **III** without depressing the accelerator pedal.

Starting to Drive

Continuously variable transmission models

1. Keeping your right foot on the brake pedal, release the parking brake. Check that the parking brake and brake system indicator has gone off.
➤ **Parking Brake** P. 217
2. Put the transmission into **D**. Select **R** when reversing.
3. Gradually release the brake pedal and gently depress the accelerator pedal to pull away.

▶▶ Starting the Engine

Do not hold the key in START **III** for more than 10 seconds.

- If the engine does not start right away, wait for at least 30 seconds before trying again.
- If the engine starts, but then immediately stops, wait at least 30 seconds before repeating step 3 while gently depressing the accelerator pedal. Release the accelerator pedal once the engine starts.

Diesel models

When the ambient temperature is extremely low, the engine peak power may be restricted at starting the engine. This is to help the fuel flow for the normal engine operation.

Diesel models

NOTICE

For proper lubrication, the engine must not be run above fast idle speed until the low oil pressure indicator goes off.
Avoid harsh acceleration or labouring the engine before the normal operating temperature has been reached.

Models with keyless access system

Starting the Engine

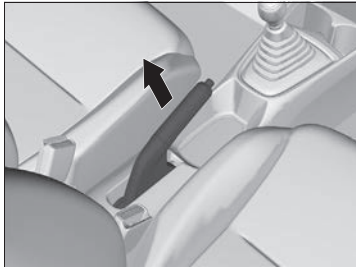

1. Make sure the parking brake is applied.

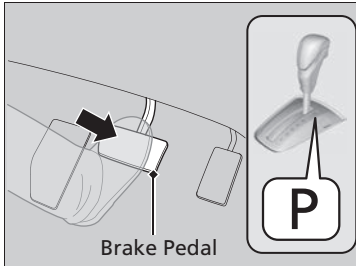

Continuously variable transmission models

2. Check that the transmission is in **P**, then depress the brake pedal.
 - Although it is possible to start the vehicle in **N**, it is safer to start it in **P**.

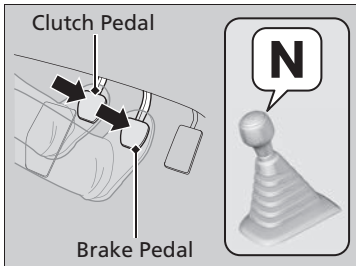

Manual transmission models

2. Check that the shift lever is in **N**. Then depress the brake pedal with your right foot, and the clutch pedal with your left foot.
 - The clutch pedal must be fully depressed to start the engine.

Starting the Engine

Keep your foot firmly on the brake pedal when starting the engine.

When starting the engine in cold weather, turn off all electrical accessories such as the lights, climate control system, and rear demister in order to reduce battery drain.

If the exhaust system sounds abnormal or you can smell exhaust gas inside the vehicle, have your vehicle checked by a dealer. There may be a problem with the engine or exhaust system.

The immobilizer system protects your vehicle from theft. If an improperly coded device is used, the engine's fuel system is disabled.

► **Immobilizer System** P. 108

The engine is harder to start in cold weather and in thinner air found at altitudes above 2,400 metres.

Continued

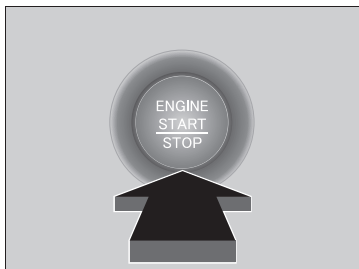

All models

3. Press the **ENGINE START/STOP** button without depressing the accelerator pedal.

Diesel models

Manual transmission models

- ▶ If the glow plugs indicator comes on, keep the clutch pedal fully depressed and wait until the indicator goes off. The engine starts automatically.

Stopping the Engine

You can turn the engine off when the vehicle is completely stopped.

Diesel models

Idle the engine for 10 seconds before turning off the engine

Continuously variable transmission models

1. Put the transmission into **P**.
2. Press the **ENGINE START/STOP** button.

Manual transmission models

- If the transmission is in **N**, press the **ENGINE START/STOP** button.
- If the transmission is in any gear other than **N**, depress the clutch pedal, then press the **ENGINE START/STOP** button.

Starting the Engine

Bring the keyless remote close to the **ENGINE START/STOP** button if the battery in the keyless remote is weak.

▶ **If the Keyless Remote Battery is Weak**
P. 292

The engine may not start if the keyless remote is subjected to strong radio waves.

Do not hold the **ENGINE START/STOP** button to start the engine. If the engine does not start, wait at least 30 seconds before starting the engine again.

Diesel models

When the ambient temperature is extremely low, the engine peak power may be restricted at starting the engine. This is to help the fuel flow for the normal engine operation.

Diesel models

For proper lubrication, the engine must not be run above fast idle speed until the low oil pressure indicator goes off. Avoid harsh acceleration or labouring the engine before the normal operating temperature has been reached.

Starting to Drive

Continuously variable transmission models

1. Keeping your right foot on the brake pedal, release the parking brake. Check that the parking brake and brake system indicator has gone off.
 - 📖 **Parking Brake** P. 217
2. Put the transmission into **D**. Select **R** when reversing.
3. Gradually release the brake pedal and gently depress the accelerator pedal to pull away.

Precautions While Driving

In a Fog

Visibility becomes low when it is foggy. When you drive, turn on the low beam headlights even during the daytime. Slow down, using the road line in the centre, guard rails, and the taillights of the vehicle ahead of you as your driving guide.

In a Strong Wind

If a strong side wind drifts your vehicle while driving, hold the steering wheel tight. Slowly decelerate your vehicle and keep your vehicle in the middle of the road. Be careful with wind gusts especially when your vehicle is exiting a tunnel, driving on a bridge or river bank, and driving through an open area like a quarry, and when a large truck is passing by.

In Rain

The road is slippery when raining. Avoid hard braking, rapid acceleration, and abrupt steering and be more cautious when driving. It is likely to experience hydroplaning phenomenon if you are driving on a rutted road with puddles. Do not drive in deep water and on flooded roads. This can damage the engine or driveline, or cause electrical component failure.

Precautions While Driving

CAUTION: Do not drive on the road where water is deep. Driving through deep water will cause damage to the engine and electrical equipment and the vehicle will break down.

NOTICE

If you repeatedly turn the steering wheel at an extremely low speed, or hold the steering wheel in the full left or right position for a while, the electric power steering (EPS) system heats up. The system goes into a protective mode, and limits its performance. The steering wheel becomes harder and harder to operate. Once the system cools down, the EPS system is restored. Repeated operation under these conditions can eventually damage the system.

If the ignition switch is turned to ACCESSORY **I***1 while driving, the engine will shut down and all steering and brake power assist functions will stop, making it difficult to control the vehicle.

Do not put the shift lever in **N**, as you will lose engine braking (and acceleration) performance.

Continuously variable transmission models

NOTICE

Do not operate the shift lever while pressing the accelerator pedal. You could damage the transmission.

* 1: Models with the keyless access system have an **ENGINE START/STOP** button instead of an ignition switch.

Other Precautions

If there is a strong impact with something under the vehicle, stop in a safe location. Check the underside of the vehicle for damage or any fluid leaks.

Precautions While Driving

During the first 1,000 km of operation, avoid sudden acceleration or full throttle operation so as not to damage the engine or powertrain.

Avoid hard braking for the first 300 km. You should also follow this when the brake pads are replaced.

In Rain

Be careful when hydroplaning phenomenon occurs. When you drive on a road covered with water at excessive speed, a layer of water builds between the tyres and the road surface. If this occurs, the vehicle cannot respond to control inputs such as steering, and braking.

Slowly decelerate when you shift down. If the road is slippery, sudden engine braking can cause the tyres to skid.

Continuously Variable Transmission *

■ Creeping

The engine runs at a higher idle speed and creeping increases.
Keep the brake pedal firmly depressed when stopped.

■ Kickdown

Quickly depressing the accelerator pedal while driving uphill may cause the transmission to drop to a lower ratio, unexpectedly increasing vehicle speed.
Depress the accelerator pedal carefully, especially on slippery roads and curves.

Continuously variable transmission models without paddle shifters

Shifting

Change the shift position in accordance with your driving needs.

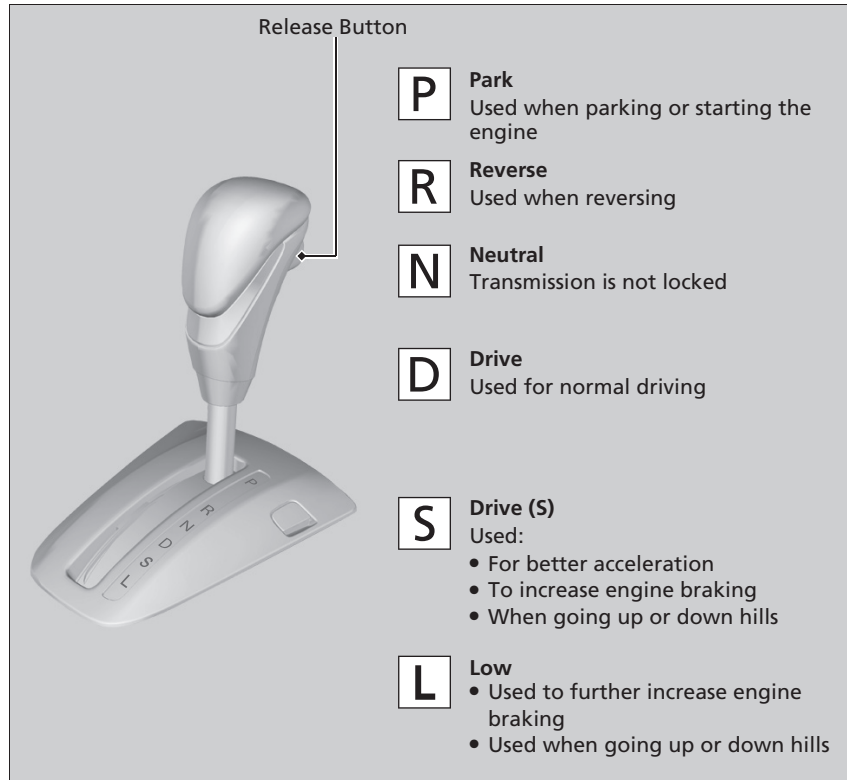
■ Shift lever positions

▶▶Shifting

Models without keyless access system

You cannot turn the ignition switch to LOCK [0] and remove the key unless the shift lever is in [P].

Models with keyless access system

You cannot change the power mode from ON to VEHICLE OFF (LOCK) unless the shift lever is in [P].

The vehicle may move very slightly even in [N] while the engine is cold.

Depress the brake pedal firmly and, when necessary, apply the parking brake.

Continued

Shift Lever Operation

Models without keyless access system

Petrol models

Diesel models

Shift Lever Position Indicator (Transmission Indicator)

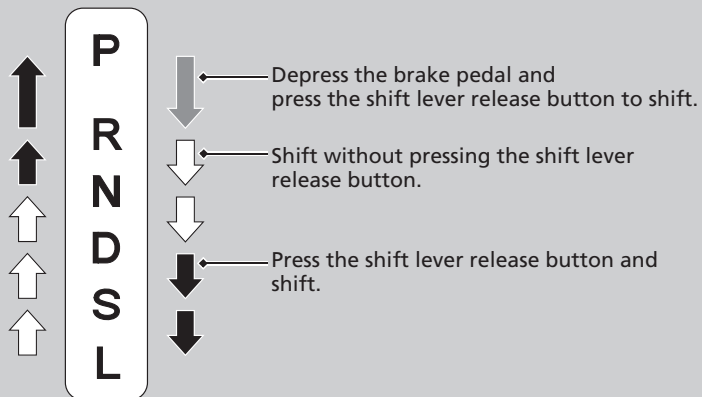
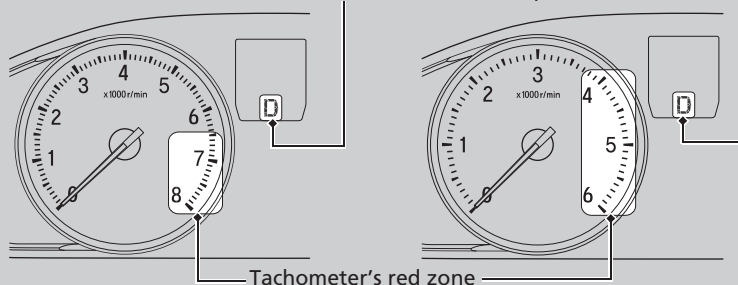

Shift Lever Operation

NOTICE

When you change the shift lever from **D** to **R** and vice versa, come to a complete stop and keep the brake pedal depressed. Operating the shift lever before the vehicle has come to a complete standstill can damage the transmission.

Use the shift lever position indicator to check the lever position before pulling away.

If the transmission indicator blinks when driving, in any shift position, there is a problem with the transmission. Avoid sudden acceleration and have the transmission checked by a dealer as soon as possible.

The fuel supply may be cut off if you drive at engine speeds in or over the tachometer's red zone (engine speed limit). If this happens, you may experience a slight jolt.

It may not be possible to operate the shift lever if the brake pedal is applied while the shift lever release button is held down. Depress the brake pedal first.

When shifting positions in extremely low temperatures (-30°C), there may be a short delay before the shift position is displayed. Always confirm you are in the correct shift position before driving.

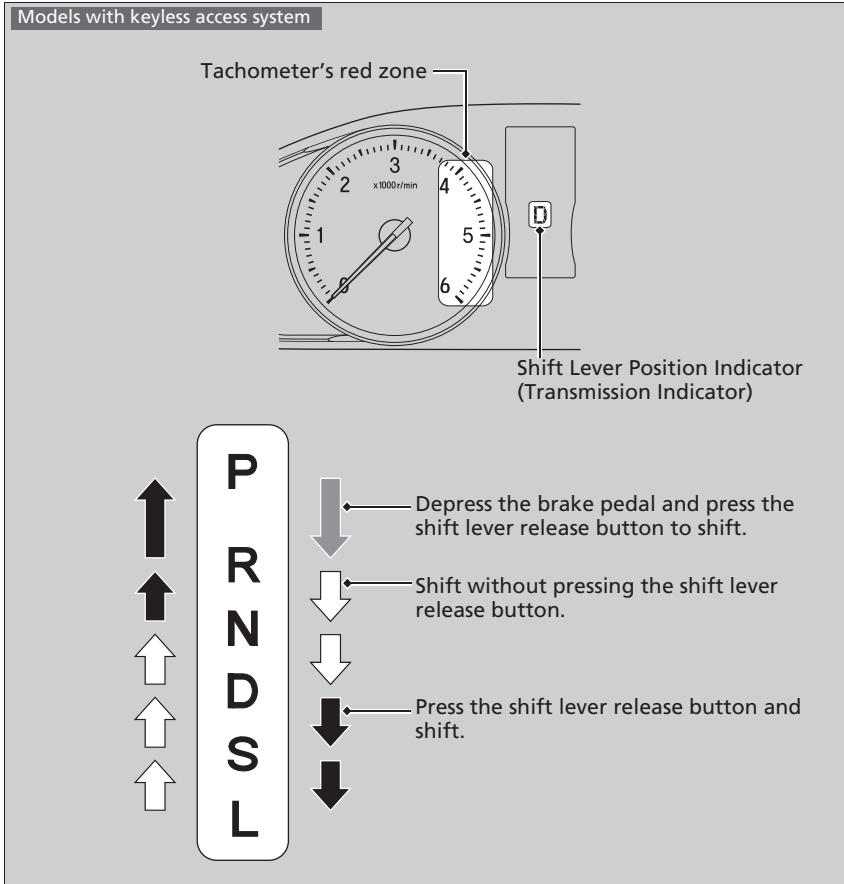

Continuously variable transmission models with paddle shifters

Shifting

Change the shift position in accordance with your driving needs.

■ Shift lever positions



Release Button

P **Park**
Used when parking or starting the engine

R **Reverse**
Used when reversing

N **Neutral**
Transmission is not locked

D **Drive**
Used:
• For normal driving
• When temporarily driving in the 7-speed manual shift mode

S **Drive (S)**
Used:
• For better acceleration
• To increase engine braking
• When going up or down hills
• When driving in the 7-speed manual shift mode

▶ Shifting

Models without keyless access system

You cannot turn the ignition switch to LOCK [O] and remove the key unless the shift lever is in [P].

Models with keyless access system

You cannot change the power mode from ON to VEHICLE OFF (LOCK) unless the shift lever is in [P].

The vehicle may move very slightly even in [N] while the engine is cold.

Depress the brake pedal firmly and, when necessary, apply the parking brake.

Shift Lever Operation

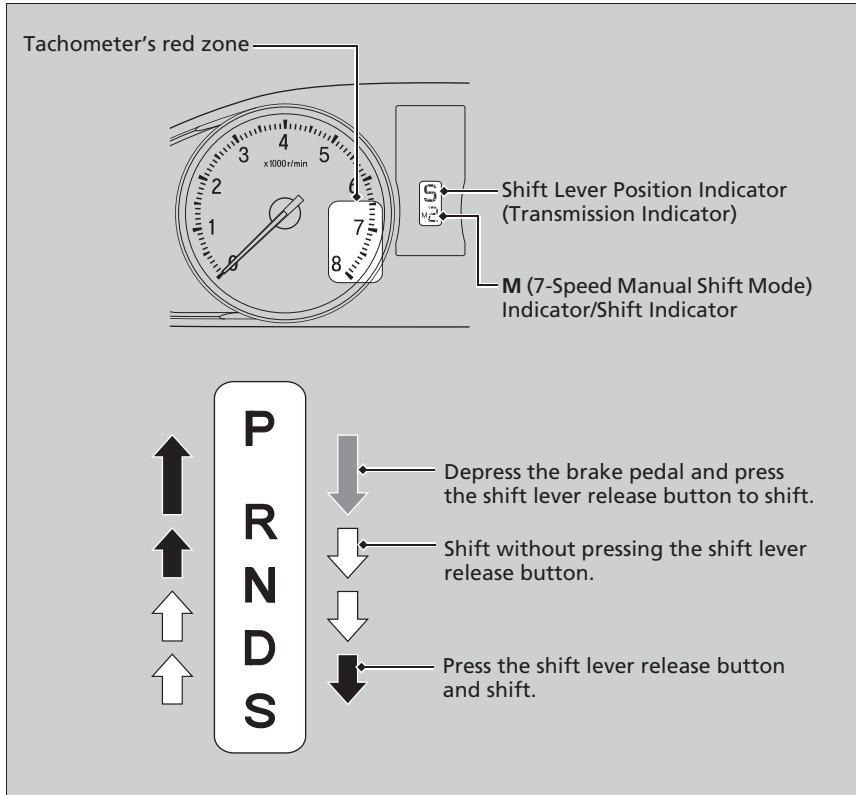

Shift Lever Operation

NOTICE

When you change the shift lever from **D** to **R** and vice versa, come to a complete stop and keep the brake pedal depressed. Operating the shift lever before the vehicle has come to a complete standstill can damage the transmission.

Use the shift lever position indicator to check the lever position before pulling away.

If the transmission indicator blinks when driving, in any shift position, there is a problem with the transmission. Avoid sudden acceleration and have the transmission checked by a dealer as soon as possible.

The fuel supply may be cut off if you drive at engine speeds in or over the tachometer's red zone (engine speed limit). If this happens, you may experience a slight jolt.

It may not be possible to operate the shift lever if the brake pedal is applied while the shift lever release button is held down. Depress the brake pedal first.

When shifting positions in extremely low temperatures (-30°C), there may be a short delay before the shift position is displayed. Always confirm you are in the correct shift position before driving.

Continued

■ 7-Speed Manual Shift Mode

Use the paddle shifters to change between 1st and 7th speeds without releasing your hands from the steering wheel. The transmission switches to the 7-speed manual shift mode when you pull a paddle shifter while driving. This mode is useful when engine braking is needed.

■ When the shift lever is in **[D]**:

The shift mode goes into the 7-speed manual shift mode temporarily, and the number is displayed in the shift indicator.

The 7-speed manual shift mode is cancelled automatically if you drive at constant speed or accelerate, and the number in the shift indicator goes off.

You can cancel this mode by pulling the **[+]** paddle shifter for a few seconds.

The 7-speed manual shift mode is especially useful when reducing the vehicle speed temporarily before making a turn.

■ When the shift lever is in **[S]**:

The shift mode goes into the 7-speed manual shift mode. The **M** indicator and the speed number are displayed in the shift indicator. As the vehicle speed slows down, the transmission automatically shifts down accordingly. When the vehicle comes to a stop, it automatically shifts down into 1st.

If the vehicle speed increases and the engine speed reaches near the tachometer's red zone, the transmission automatically shifts up.

You can only pull away in 1st speed.

When canceling the 7-speed manual shift mode, move the shift lever from **[S]** to **[D]**. When the 7-speed manual shift mode is cancelled, the **M** indicator and shift indicator will turn off.

⊗ 7-Speed Manual Shift Mode

In the 7-speed manual shift mode, the transmission shifts up or down by operating either paddle shifter under the following conditions:

Shift Up: The engine speed reaches the lowest threshold of the higher speed position.

Shift Down: The engine speed reaches the highest threshold of the lower speed position.

When the engine speed reaches near the tachometer's red zone, the transmission shifts up automatically.

When the engine speed reaches the lowest threshold of the selected speed position, the transmission shifts down automatically.

Operating the paddle shifters on slippery surfaces may cause the tyres to lock up. In this case, the 7-speed manual shift mode is cancelled and goes back to the normal D driving mode.

7-Speed Manual Shift Mode Operation

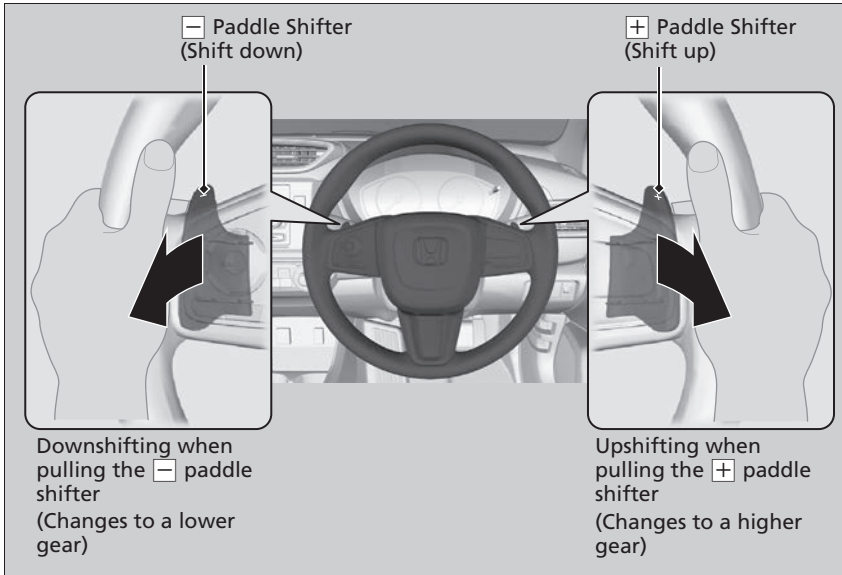

7-Speed Manual Shift Mode Operation

Each paddle shift operation makes a single speed change.

To change continuously, release the paddle shifter before pulling it again for the next speed.

The shift indicator blinks when you cannot shift up or down. It indicates that your vehicle speed is not in its allowable shifting range.

Slightly accelerate to shift up and decelerate to shift down while the indicator is blinking.

Manual transmission models

Shifting

Shift Lever Operation

Fully depress the clutch pedal to operate the shift lever and change gears, then slowly release the pedal.

Depress the clutch pedal, and pause for a few seconds before shifting into **R**, or shift into one of the forward gears for a moment. This stops the gears so they do not “grind.”

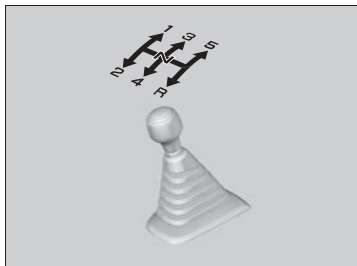

When you are not shifting, do not rest your foot on the clutch pedal. This can cause your clutch to wear out faster.

Shifting

NOTICE

Do not shift to **R** before the vehicle comes to a complete stop. Shifting to **R** before stopping can damage the transmission.

NOTICE

Before downshifting, make sure the engine will not go into the tachometer's red zone. Should this occur, it can severely damage your engine.

There is a metallic part on the shift lever. If you leave the vehicle parked outside for a long time on a hot day, be careful before moving the shift lever. Because of heat, the shift lever may be extremely hot. If the outside temperature is low, the shift lever may feel cold.

If you exceed the maximum speed for the gear you are in, the engine speed will enter into the tachometer's red zone. When this happens, you may experience a slight jolt.

■ Reverse Lockout

Your vehicle's lockout mechanism stops you from accidentally shifting into **R** from the 5th gear. Always shift to **N** first, then to **R**.

Cruise Control*

Maintains a constant vehicle speed without having to keep your foot on the accelerator. Use cruise control on motorways or open roads where you can travel at a constant speed with little acceleration or deceleration.

When to use

- Vehicle speed for cruise control:
Desired speed in a range above roughly 40 km/h ~
- Shift positions for cruise control:
In **2** or higher position

Always keep sufficient distance between you and the vehicle in front of you

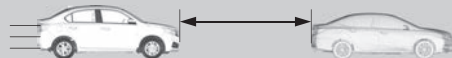

How to use

- Press the **CRUISE** button on the steering wheel.



CRUISE MAIN is on in the instrument panel.
Cruise control is ready to use.

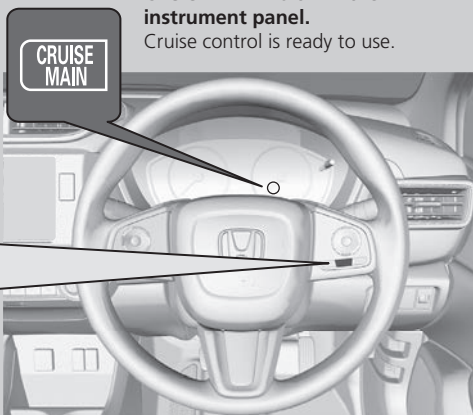

⚠ Cruise Control*

⚠ WARNING

Improper use of the cruise control can lead to a crash.

Use the cruise control only when travelling on open motorways in good weather.

It may not be possible to maintain a constant speed when driving uphill or downhill.

When the engine speed slows down, try to downshift. You can maintain the set speed if you change gear within five seconds.

When not using cruise control:
Turn off cruise control by pressing the **CRUISE** button.

■ To Set the Vehicle Speed

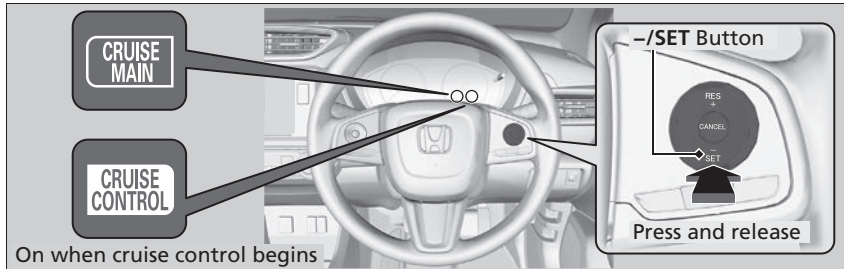

Take your foot off the pedal and press the **-/SET** button when you reach the desired speed.

The moment you release the **-/SET** button, the set speed is fixed, and cruise control begins. The **CRUISE CONTROL** indicator comes on.

Continued

To Adjust the Vehicle Speed

Increase or decrease the vehicle speed using the **RES/+** or **-/SET** button on the steering wheel.

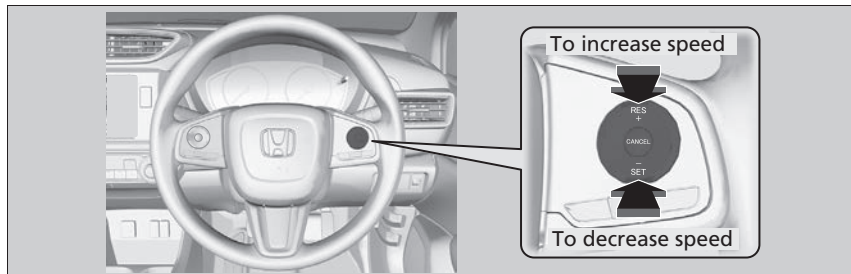

- Each time you press the button, the vehicle speed is increased or decreased by about 1.6 km/h.
- If you keep the button pressed, the vehicle speed increases or decreases until you release it. This speed is then set.

To Cancel

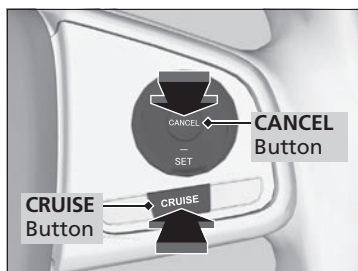

To cancel cruise control, do any of the following:

- Press the **CANCEL** button.
- Press the **CRUISE** button.
- Depress the brake pedal.
- Depress the clutch pedal for five seconds or more.

The **CRUISE CONTROL** indicator goes off.

To Adjust the Vehicle Speed

You can set the vehicle speed using the **-/SET** button on the steering wheel when adjusting the speed with the accelerator and brake pedals.

To Cancel

Resuming the prior set speed:

After cruise control has been cancelled, you can still resume the prior set speed by pressing the **RES/+** button while driving at a speed of at least 40 km/h or more.

You cannot set or resume in the following situations:

- When vehicle speed is less than 40 km/h
- When the **CRUISE** button is turned off

At vehicle speeds of 35 km/h or less, cruise control is cancelled automatically.

Brake System

■ Parking Brake

Use the parking brake to keep the vehicle stationary when parking.

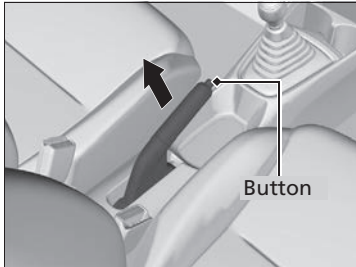

To apply:

Pull the lever fully up without pressing the release button.

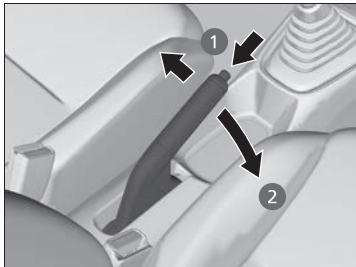

To release:

1. Pull the lever slightly, and press and hold the release button.
2. Lower the lever down all the way, then release the button.

» Parking Brake

NOTICE

Release the parking brake fully before driving. The rear brakes and axle can be damaged if you drive with the parking brake applied.

If you start driving without fully releasing the parking brake, a buzzer sounds as a warning.

Always apply the parking brake when parking.

Continued

■ Foot Brake

Your vehicle is equipped with disc brakes at the front, and drum brakes in the rear wheels. A vacuum power assist helps to reduce the effort needed on the brake pedal.

The anti-lock brake system (ABS) helps you retain steering control when braking very hard.

✎ **Anti-lock Brake System (ABS)** P. 219

✎ Foot Brake

Check the brakes after driving through deep water, or if there is a buildup of road surface water. If necessary, dry the brakes by lightly depressing the pedal several times.

If you hear a continuous metallic friction sound when applying the brakes, the brake pads need to be replaced. Have the vehicle checked by a dealer.

Constantly using the brake pedal while going down a long hill builds up heat, which reduces the brake effectiveness. Apply engine braking by taking your foot off the accelerator pedal and downshifting to a lower gear/speed position. With manual transmission* use a lower gear for greater engine braking.

Do not rest your foot on the brake pedal while driving, as it will lightly apply the brakes and cause them to lose effectiveness over time and reduce pad life. It will also confuse drivers behind you.

Anti-lock Brake System (ABS)

■ ABS

Helps to prevent the wheels from locking up, and helps you to retain steering control by pumping the brakes rapidly, much faster than you.

The electronic brake distribution (EBD) system, which is part of the ABS, also balances the front-to-rear braking distribution according to vehicle loading.

You should never pump the brake pedal. Let the ABS work for you by always keeping firm, steady pressure on the brake pedal. This is sometimes referred to as “stomp and steer.”

■ ABS operation

The brake pedal may pulsate slightly when the ABS is working. Depress the brake pedal and keep holding the pedal firmly down. On dry pavement, you will need to press on the brake pedal very hard before the ABS activates. However, you may feel the ABS activate immediately if you are trying to stop on snow or ice.

ABS may activate when you depress the brake pedal when driving on:

- Wet or snow covered roads.
- Roads paved with stone.
- Roads with uneven surfaces, such as potholes, cracks, manholes, etc.

When the vehicle speed goes under 10 km/h, the ABS stops.

▶▶ Anti-lock Brake System (ABS)

NOTICE

The ABS may not function correctly if you use a tyre of the wrong size or type.

If the **ABS** indicator comes on while driving, there may be a problem with the system.

While normal braking will not be affected, there is a possibility that the ABS will not be operating. Have your vehicle checked by a dealer immediately.

The ABS is not designed for the purpose of reducing the time or distance it takes for a vehicle to stop: It is designed to limit brake lockup which can lead to skidding and loss of steering control.

In the following cases, your vehicle may need more distance to stop than a vehicle without the ABS:

- You are driving on rough or uneven road surfaces, such as gravel or snow.

The following may be observed with the ABS system:

- Motor sounds coming from the engine compartment when the brakes are applied, or when system checks are being performed after the engine has been started and while the vehicle accelerates.
- Brake pedal and/or the vehicle body vibration when ABS activates.
These vibrations and sounds are normal to ABS systems and are no cause for concern.

Parking Your Vehicle

When Stopped

1. Depress the brake pedal firmly.
2. Apply the parking brake.

Continuously variable transmission models

3. Change the shift position to **P**.

Manual transmission models

3. Move the shift lever to **1** or **R**.

Diesel models

4. Keep idling the engine for about 10 seconds.

All models

5. Turn off the engine.

Always set the parking brake firmly, in particular if you are parking on an incline.

» Parking Your Vehicle

Continuously variable transmission models

⚠ WARNING

The vehicle can roll away if left unattended without confirming that Parking brake is engaged.

A vehicle that rolls away could cause a crash resulting in serious injury or death.

Always keep your foot on the brake pedal until you have confirmed that **P** is shown on the shift lever position indicator.

Do not park your vehicle near flammable objects, such as dry grass, oil, or timber. Heat from the exhaust can cause a fire.

» When Stopped

Continuously variable transmission models

NOTICE

The following can damage the transmission:

- Depressing the accelerator and brake pedals simultaneously.
- Holding the vehicle in place when facing uphill by depressing the accelerator pedal.
- Moving the shift lever into **P** before the vehicle stops completely.

» When Stopped

Diesel models

The engine idling may be prohibited in some countries. Check and follow your local legal requirements.

All models

In extremely cold temperatures, the parking brake may freeze up if applied. If such temperatures are expected, do not apply the parking brake but, if parking on a slope, either turn the front wheels so they will contact the curb if the vehicle rolls down the slope or block the wheels to keep the vehicle from moving. If you do not take either precaution, the vehicle may roll unexpectedly, leading to a crash.

Parking Sensor System

The rear corner and centre sensors monitor obstacles behind your vehicle, and the beeper lets you know the approximate distance between your vehicle and the obstacle.

■ The sensor location and range

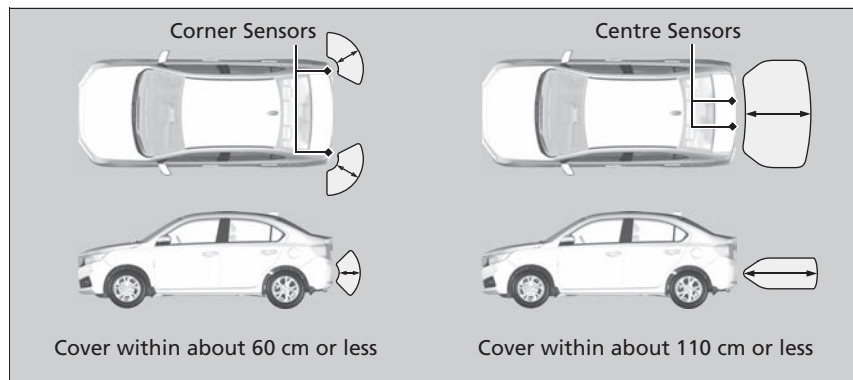

The system activates when the shift lever is in **[R]**, and the vehicle speed is less than 8 km/h.

Manual transmission models

You also need to release the parking brake.

⚠ Parking Sensor System

Even when the system is on, always confirm if there is no obstacle near your vehicle before parking.

The system may not work properly when:

- The sensors are covered with snow, ice, mud, or dirt.
- The vehicle is on uneven surface, such as grass, bumps, or a hill.
- The vehicle has been out in hot or cold weather.
- The system is affected by devices that emit ultrasonic waves.
- Driving in bad weather.

The system may not sense:

- Thin or low objects.
- Sonic-absorptive materials, such as snow, cotton, or sponge.
- Objects directly under the bumper.

Do not put any accessories on or around the sensors.

■ **When the distance between your vehicle and obstacles becomes shorter**

Length of the intermittent beep	Distance between the Bumper and Obstacle	
	Corner Sensors	Centre Sensors
Moderate	–	About 110-60 cm
Short	About 60-45 cm	About 60-45 cm
Very short	About 45-35 cm	About 45-35 cm
Continuous	About 35 cm or less	About 35 cm or less

Refueling

Petrol models

Fuel Information

■ Fuel recommendation

Unleaded petrol, research octane number 91 or higher

Use of lower octane petrol can cause a persistent, heavy metallic knocking noise that can lead to engine damage.

■ Fuel tank capacity: 35 L

⌕ Fuel Information

NOTICE

Use of petrol that contains lead presents the following risks:

- Damage to the exhaust system including the catalytic converter
- Damage to the engine and fuel system
- Detrimental effects on the engine and other systems

Diesel models

Fuel Information

■ Fuel recommendation

Automotive Diesel Fuel

Use the automotive diesel fuel specified with a cetane number 51 or higher and up to 350 ppm of sulfur.

Select the proper fuel of clean and good quality according to the regional and climate condition. Use of improper fuel can reduce engine power.

■ Fuel tank capacity: 35 L

» Fuel Information

NOTICE

Serious damage may occur if petrol is used in diesel engines.

Your vehicle is not designed to use Biodiesel (pure or high concentration more than 7% vol). Consult a dealer for more information.

NOTICE

Not using the recommended automotive diesel fuel can cause the decreased engine performance.

Never use the heating oil and marine diesel fuel.

We recommend to replace the fuel filter before starting to drive if you have parked your vehicle for an extended period. The fuel filter may become clogged earlier than usual.

How to Refuel

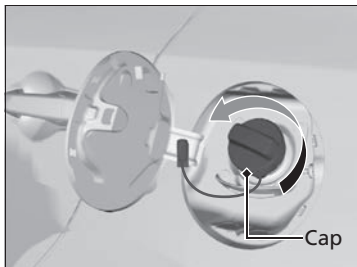

1. Stop your vehicle with the service station pump on the left side of the vehicle in the rear.
2. Turn off the engine.
3. Pull on the fuel fill door release handle under the driver's side lower outside corner of the dashboard.
 - ▶ The fuel fill door opens.
4. Remove the fuel fill cap slowly. If you hear a release of air, wait until this stops, then turn the knob slowly to open the fuel fill cap.

How to Refuel

⚠ WARNING

Fuel is highly flammable and explosive. You can be burned or seriously injured when handling fuel.

- Stop the engine, and keep heat, sparks, and flame away.
- Handle fuel only outdoors.
- Wipe up spills immediately.

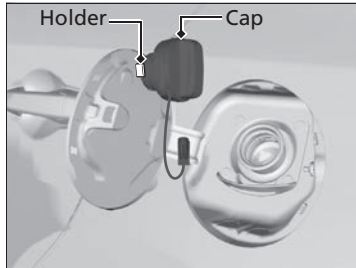

5. Place the fuel fill cap in the holder.
6. Insert the fuel filler nozzle fully.
 - ▶ When the tank is full, the filler nozzle will click off automatically. This leaves space in the fuel tank in case the fuel expands with a change in the temperature.
7. After filling, replace the fuel fill cap, tightening it until you hear it click at least once.
 - ▶ Shut the fuel fill door by hand.

▣ How to Refuel

The filler nozzle automatically stops to leave space in the fuel tank so that fuel does not overflow as a result of changes in air temperature.

Do not continue to add fuel after the filler nozzle has automatically stopped. Additional fuel can exceed the full tank capacity.

Fuel Economy and CO₂ Emissions

Improving Fuel Economy and Reducing CO₂ Emissions

Achieving fuel economy and reducing CO₂ emissions is dependent on several factors, including driving conditions, load weight, idling time, driving habits, and vehicle condition. Depending on these and other factors, you may not achieve the rated fuel economy of this vehicle.

Maintenance and Fuel Economy

You can optimize your fuel economy with proper maintenance of your vehicle. Follow the maintenance schedule and, if necessary, consult your warranty booklet.

➤ **Maintenance Schedule** P. 233

- Use engine oil with the viscosity recommended.
 - **Recommended Engine Oil** P. 243
- Maintain the specified tyre pressure.
- Do not load the vehicle with excess luggage.
- Keep your vehicle clean. A buildup of snow or mud on your vehicle's underside adds weight and increases wind resistance.

Improving Fuel Economy and Reducing CO₂ Emissions

Direct calculation is the recommended method to determine actual fuel consumed while driving.

100	×	Litres of fuel	÷	Kilometres driven	=	L per 100 km
Kilometres driven	÷	Litres of fuel	=	Kilometres per Litre		

Maintenance

This chapter discusses basic maintenance.



Before Performing Maintenance

Inspection and Maintenance	230
Safety When Performing Maintenance	231
Parts and Fluids Used in Maintenance Service	232

Maintenance Schedule

Maintenance Under the Bonnet

Maintenance Items Under the Bonnet	240
Opening the Bonnet	242
Recommended Engine Oil	243
Oil Check	245
Adding Engine Oil	247

Engine Coolant	248
Transmission Fluid	252
Brake/Clutch* Fluid	254
Refilling Window Washer Fluid	255

Replacing Light Bulbs

Checking and Maintaining Wiper Blades	266
--	-----

Checking and Maintaining Tyres

Checking Tyres	268
Wear Indicators	269
Tyre Service Life	269
Tyre and Wheel Replacement	270

Tyre Rotation	271
---------------------	-----

Battery

Remote Transmitter Care*

Replacing the Button Battery	274
------------------------------------	-----

Cleaning

Interior Care	276
Exterior Care	277

Accessories and Modifications

* Not available on all models

Before Performing Maintenance

Inspection and Maintenance

For your safety, perform all listed inspections and maintenance to keep your vehicle in good condition. If you become aware of any abnormality (noise, smell, insufficient brake fluid, oil residue on the ground, etc.), have your vehicle inspected by a dealer. Refer to the maintenance schedule in this owner's manual for detailed maintenance and inspection information.

➤ **Maintenance Schedule** P. 233

Types of Inspection and Maintenance

■ Daily inspections

Perform inspections before long distance trips, when washing the vehicle, or when refueling.

■ Periodic inspections

- Check the brake fluid level monthly.
➤ **Brake/Clutch* Fluid** P. 254
- Check the tyre pressure monthly. Examine the tread for wear and foreign objects.
➤ **Checking and Maintaining Tyres** P. 268
- Check the operation of the exterior lights monthly.
➤ **Replacing Light Bulbs** P. 256
- Check the condition of the wiper blades at least every six months.
➤ **Checking and Maintaining Wiper Blades** P. 266

Safety When Performing Maintenance

Some of the most important safety precautions are given here. However, we cannot warn you of every conceivable hazard that can arise in performing maintenance. Only you can decide whether you should perform a given task.

Maintenance Safety

- To reduce the possibility of fire or explosion, keep cigarettes, sparks, and flames away from the battery and all fuel related parts.
- Never leave rags, towels, or other flammable objects under the bonnet.
 - ▶ Heat from the engine and exhaust can ignite them, causing a fire.
- To clean parts, use a commercially available degreaser or parts cleaner, not petrol.
- Wear eye protection and protective clothing when working with the battery or compressed air.
- Engine exhaust contains carbon monoxide, which is poisonous and can kill you.
 - ▶ Only operate the engine if there is sufficient ventilation.

Vehicle Safety

- The vehicle must be in a stationary condition.
 - ▶ Make sure your vehicle is parked on level ground, the parking brake is set, and the engine is off.
- Be aware that hot parts can burn you.
 - ▶ Make sure to let the engine and exhaust system cool thoroughly before touching vehicle parts.
- Be aware that moving parts can injure you.
 - ▶ Do not start the engine unless instructed, and keep your hands and limbs away from moving parts.

⚠ Safety When Performing Maintenance

⚠ WARNING

Improperly maintaining this vehicle or failing to correct a problem before driving can cause a crash in which you can be seriously hurt or killed.

Always follow the inspection and maintenance recommendations and schedules in this owner's manual.

⚠ WARNING

Failure to properly follow maintenance instructions and precautions can cause you to be seriously hurt or killed.

Always follow the procedures and precautions in this owner's manual.

Parts and Fluids Used in Maintenance Service

The use of Honda genuine parts and fluids is recommended when maintaining and servicing your vehicle. Honda genuine parts are manufactured according to the same high quality standards used in Honda vehicles.

▶▶ Parts and Fluids Used in Maintenance Service

Diesel models

NOTICE

Do not press the engine cover forcibly. This may damage the engine cover and component parts.

Maintenance Schedule

If your vehicle comes with the Service Book (Warranty Booklet), the maintenance schedule for your vehicle is available in the book. For vehicles without the Service Book (Warranty Booklet), refer to the following maintenance schedule.

The maintenance schedule outlines the minimum required maintenance that you should perform to ensure the troublefree operation of your vehicle. Due to regional and climatic differences, some additional servicing may be required. Please consult your warranty booklet for a more detailed description.

Maintenance work should be performed by properly trained and equipped technicians. Your authorised dealer meets all of these requirements.

Petrol models

Service at the Indicated Distance or Time - Whichever comes first.	Km X 1000	1	5	10	20	30	40	50	60	70	80	90	100	110	120	130	140	150	160	170	180	190	200	
	Months	1	6	12	24	36	48	60	72	84	96	108	120	132	144	156	168	180	192	204	216	228	240	
Replace Engine Oil ¹				•	•	•	•	•	•	•	•	•	•	•	•	•	•	•	•	•	•	•	•	•
Replace Engine Oil ²	Normal			•	•	•	•	•	•	•	•	•	•	•	•	•	•	•	•	•	•	•	•	•
	Severe ³	Every 5,000 km or 6 Months																						
Replace Engine Oil Filter ¹				•	•	•	•	•	•	•	•	•	•	•	•	•	•	•	•	•	•	•	•	•
Replace Engine Oil Filter ²	Normal			•	•	•	•	•	•	•	•	•	•	•	•	•	•	•	•	•	•	•	•	•
	Severe ³			•	•	•	•	•	•	•	•	•	•	•	•	•	•	•	•	•	•	•	•	•
Clean Air Cleaner Element		Every 10,000 km, but No clean at replace																						
Replace Air Cleaner Element ¹				•	•	•	•	•	•	•	•	•	•	•	•	•	•	•	•	•	•	•	•	•
Replace Air Cleaner Element ²		Every 30,000 km																						

¹ For Indian Market

² Except Indian Market

³ Refer to page 235 for the replacement information under the severe driving condition.

⁴ It is recommended to replace the fuel filter if the fuel you are using is suspected to be contaminated with dust, etc. because the filter may be clogged sooner.

⁵ Sensory Method. Adjust the valves during services 120,000 km if they are noisy.

►► Maintenance Schedule ►

Service at the Indicated Distance or Time - Whichever comes first.	Km X 1000	1	5	10	20	30	40	50	60	70	80	90	100	110	120	130	140	150	160	170	180	190	200	
	Months	1	6	12	24	36	48	60	72	84	96	108	120	132	144	156	168	180	192	204	216	228	240	
Inspect Valve Clearance ⁵																•								
Replace Fuel Filter ¹		Every 120,000 km or 6 Years ⁴																						
Replace Fuel Filter ²	Normal	Every 140,000 km																						
	Severe ⁴	Every 90,000 km																						
Replace Spark Plug							•				•				•				•				•	
Inspect Drive Belt				•		•		•		•		•		•		•		•		•		•		•
Replace Engine Coolant		At 2,00,000 km or 10 Years, thereafter every 1,00,000 km or 5 Years																						
Replace Transmission Fluid	Normal	Every 120,000 km or 6 Years																						
	Severe ³	Every 60,000 km or 3 Years																						
Inspect Front and Rear Brakes			•	•	•	•	•	•	•	•	•	•	•	•	•	•	•	•	•	•	•	•	•	•
Replace Brake Fluid		Every 3 Years																						
Check Parking Brake Adjustment			•	•	•	•	•	•	•	•	•	•	•	•	•	•	•	•	•	•	•	•	•	•
Rotate Tyres (Check tyre inflation and condition at least once per month)			•	•	•	•	•	•	•	•	•	•	•	•	•	•	•	•	•	•	•	•	•	•
Visually Inspect the Following Items:																								
Tie Rod Ends, Steering Gear Box, and Boots Suspension Components, Drive Shaft Boots		•	•	•	•	•	•	•	•	•	•	•	•	•	•	•	•	•	•	•	•	•	•	•
Brakes Hoses and Lines (Including ABS) All Fluid Levels and Condition of Fluid Exhaust System Fuel Lines and Connections		•	•	•	•	•	•	•	•	•	•	•	•	•	•	•	•	•	•	•	•	•	•	•

¹ For Indian Market

² Except Indian Market

³ Refer to page 235 for the replacement information under the severe driving condition.

⁴ It is recommended to replace the fuel filter if the fuel you are using is suspected to be contaminated with dust, etc. because the filter may be clogged sooner.

⁵ Sensory Method. Adjust the valves during services 120,000 km if they are noisy.

If you drive your vehicle under severe conditions, you must have the following items served to the maintenance schedule indicated as Severe.

Items	Condition
Engine oil and filter	A, B, C, D and E
Manual transmission fluid	B, D

► Maintenance Schedule

The condition is considered as severe when you drive:

- A. Less than 8 km, or less than 16 km in freezing temperatures per trip.
- B. In extremely hot temperature above 35°C.
- C. With extensive idling or long periods of stop-and-go.
- D. With loaded roof rack, or in mountains.
- E. On muddy, dusty or de-iced roads.

Continued

►► Maintenance Schedule ►

Diesel models

Service at the Indicated Distance or Time - Whichever comes first.	Km X 1000	1	5	10	20	30	40	50	60	70	80	90	100	110	120	130	140	150	160	170	180	190	200	
	Months	1	6	12	24	36	48	60	72	84	96	108	120	132	144	156	168	180	192	204	216	228	240	
Replace Engine Oil and Filter ¹				•	•	•	•	•	•	•	•	•	•	•	•	•	•	•	•	•	•	•	•	
Replace Engine Oil and Filter ²	Normal			•	•	•	•	•	•	•	•	•	•	•	•	•	•	•	•	•	•	•	•	
	Severe ³	Every 5,000 km or 6 Months																						
Replace Air Cleaner Element					•		•		•		•		•		•		•		•		•		•	
Replace Fuel Filter ¹				•		•		•		•		•		•		•		•		•		•		
Replace Fuel Filter ²		Every 30,000 km																						
Water Draining from Diesel Filter ¹		•	•	•		•		•		•		•		•		•		•		•		•		
Inspect Drive Belt				•		•		•		•		•		•		•		•		•		•		
Replace Engine Coolant		At 1,00,000 km or 5 years, thereafter every 60,000 km or 3 years																						
Replace Transmission Fluid	Normal	Every 120,000 km or 6 Years																						
	Severe ³	Every 60,000 km or 3 Years																						

¹ For Indian Market

² Except Indian Market

³ Refer to page 238 for the replacement information under the severe driving condition.

Service at the Indicated Distance or Time - Whichever comes first.	Km X 1000	1	5	10	20	30	40	50	60	70	80	90	100	110	120	130	140	150	160	170	180	190	200
	Months	1	6	12	24	36	48	60	72	84	96	108	120	132	144	156	168	180	192	204	216	228	240
Inspect Front and Rear Brakes				•	•	•	•	•	•	•	•	•	•	•	•	•	•	•	•	•	•	•	•
Replace Brake Fluid		Every 3 years																					
Check Parking Brake Adjustment				•	•	•	•	•	•	•	•	•	•	•	•	•	•	•	•	•	•	•	•
Rotate Tyres (Check tyre inflation and condition at least once per month)				•	•	•	•	•	•	•	•	•	•	•	•	•	•	•	•	•	•	•	•
Visually Inspect the Following Items:																							
Tie Rod Ends, Steering Gear Box, and Boots Suspension Components Drive Shaft Boots		•	•	•	•	•	•	•	•	•	•	•	•	•	•	•	•	•	•	•	•	•	•
Brakes Hoses and Lines (Including ABS) All Fluid Levels and Condition of Fluid Exhaust System Fuel Lines and Connections		•	•	•	•	•	•	•	•	•	•	•	•	•	•	•	•	•	•	•	•	•	•

If you drive your vehicle under severe conditions, you must have the following items served to the maintenance schedule indicated as Severe.

Items	Condition
Engine oil and filter	A, B, C, D and E
Manual transmission fluid	B, D

✎ Maintenance Schedule

The condition is considered as severe when you drive:
A. Less than 8 km, or less than 16 km in freezing temperatures per trip.

B. In extremely hot temperature above 35°C.

C. With extensive idling or long periods of stop-and-go.

D. With loaded roof rack, or in mountains.

E. On muddy, dusty or de-iced roads.

Maintenance Record

Have your servicing dealer record all required maintenance below. Keep receipts for all work done on your vehicle.

Km or Month	Date	Sign or Stamp
20,000 km (or 24 Mo.)		
40,000 km (or 48 Mo.)		
60,000 km (or 72 Mo.)		
80,000 km (or 96 Mo.)		
100,000 km (or 120 Mo.)		
120,000 km (or 144 Mo.)		
140,000 km (or 168 Mo.)		
160,000 km (or 192 Mo.)		
180,000 km (or 216 Mo.)		
200,000 km (or 240 Mo.)		

Maintenance

Maintenance Under the Bonnet

Maintenance Items Under the Bonnet

Petrol models

Brake/clutch* Fluid (Black Cap)

Engine Oil Fill Cap

Engine Oil Dipstick (Orange)

Washer Fluid (Blue Cap)

Radiator Cap

Battery

Engine Coolant Reserve Tank

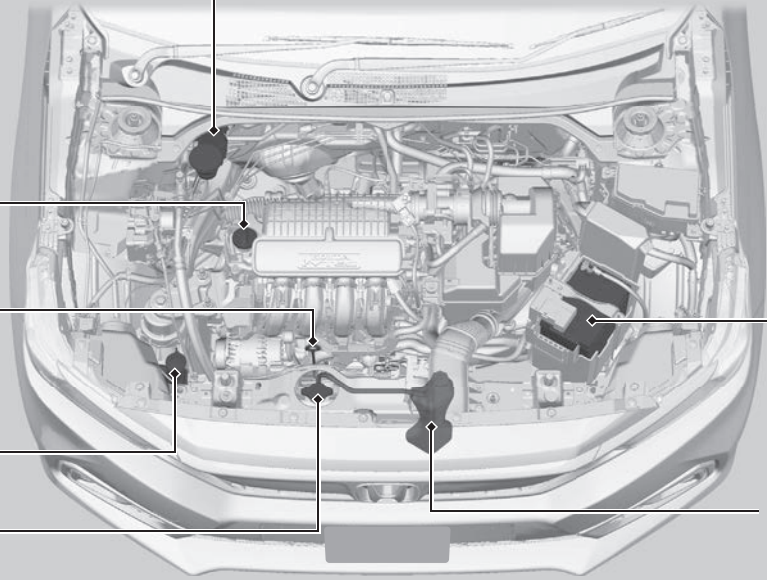

Maintenance

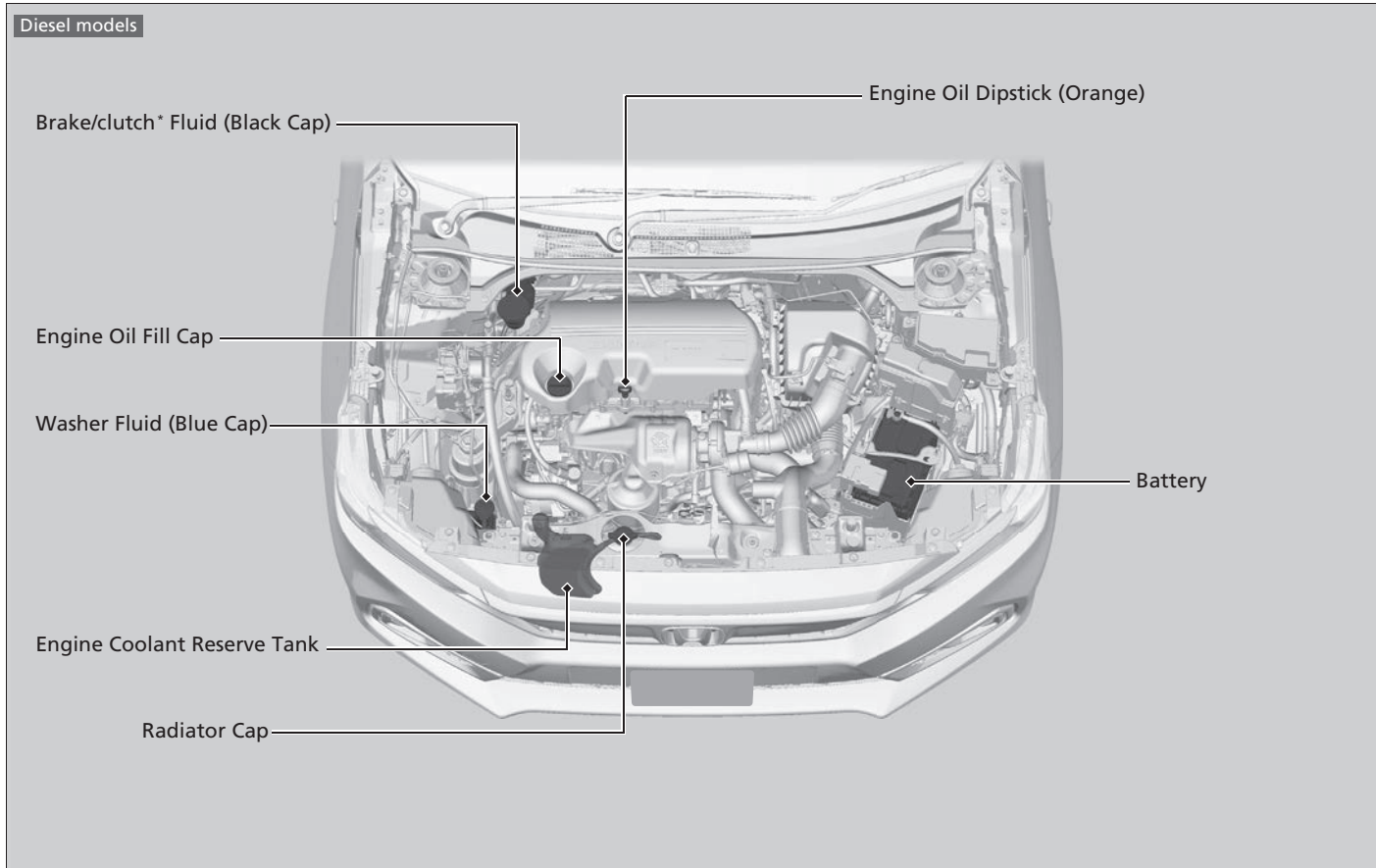

* Not available on all models

Opening the Bonnet

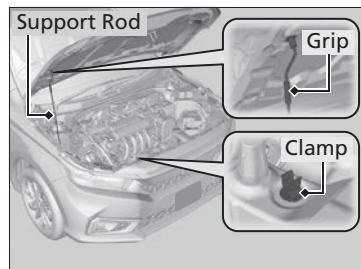
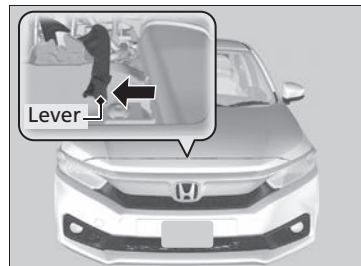
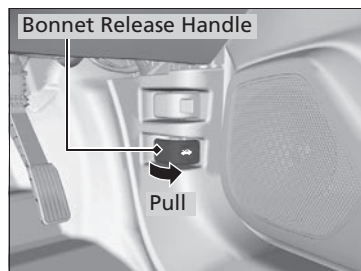

1. Park the vehicle on a level surface, and set the parking brake.
2. Pull the bonnet release handle under the driver's side lower outside corner of the dashboard.
 - The bonnet will pop up slightly.
3. Push the bonnet latch lever (located under the front edge of the bonnet to the centre) to the side and raise the bonnet. Once you have raised the bonnet slightly, you can release the lever.

4. Remove the support rod from the clamp using the grip. Mount the support rod in the bonnet.

When closing, remove the support rod, and stow it in the clamp, then gently lower the bonnet. Remove your hand at a height of approximately 30 cm and let the bonnet close.

Opening the Bonnet

NOTICE

Do not open the bonnet when the wiper arms are raised. The bonnet will strike the wipers, resulting in possible damage to the bonnet and/or the wipers.

When closing the bonnet, check that the bonnet is securely latched.

If the bonnet latch lever moves stiffly, or if you can open the bonnet without lifting the lever, the latch mechanism should be cleaned and lubricated.

Diesel models

NOTICE

Do not press the engine cover forcibly. This may damage the engine cover and component parts.

Recommended Engine Oil

Use a genuine engine oil or another commercial engine oil of suitable viscosity for the ambient temperature as shown in the image that follows.

Oil is a major contributor to your engine's performance and longevity. If you drive the vehicle with insufficient or deteriorated oil, the engine may fail or be damaged.

Recommended Engine Oil

Engine Oil Additives

Your vehicle does not require oil additives. In fact, they may adversely affect the engine performance and durability.

Continued

Petrol models

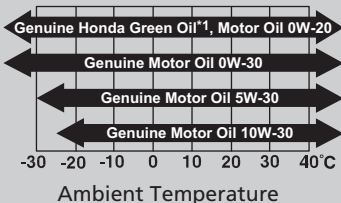
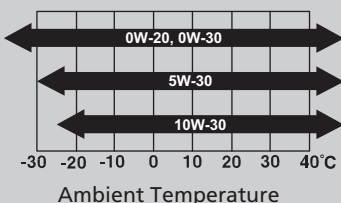
Genuine Engine Oil	Commercial Engine Oil
<ul style="list-style-type: none"> • Genuine Honda Green Oil • Genuine Honda Motor Oil 	<ul style="list-style-type: none"> • API service SM or higher grade fuel-efficient oil • ACEA A5 or B5
	

Diesel models

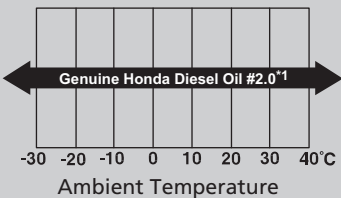
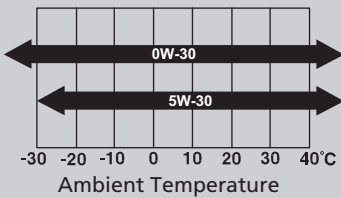
Genuine Engine Oil	Commercial Engine Oil
<ul style="list-style-type: none"> • Genuine Honda Diesel Oil # 2.0 	<ul style="list-style-type: none"> • ACEA C2 or C3
	

*1: Formulated to improve fuel economy.

Oil Check

We recommend that you check the engine oil level every time you refuel.
Park the vehicle on level ground.

Wait approximately three minutes after turning the engine off before you check the oil.

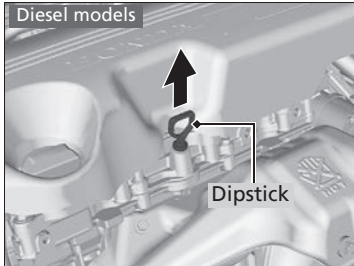
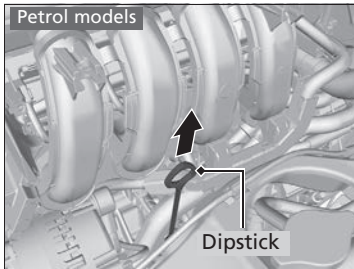

1. Remove the dipstick (orange).
2. Wipe the dipstick with a clean cloth or paper towel.
3. Insert the dipstick back all the way into its hole.

Oil Check

If the oil level is near or below the lower mark, slowly add oil, being careful not to overfill.

The amount of oil consumed depends on how the vehicle is driven and the climatic and road conditions encountered. The rate of oil consumption can be up to 1 litre per 1,000 km.

Consumption is likely to be higher when the engine is new.

Continued

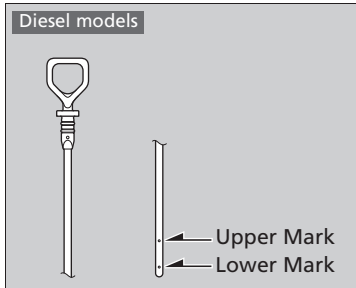
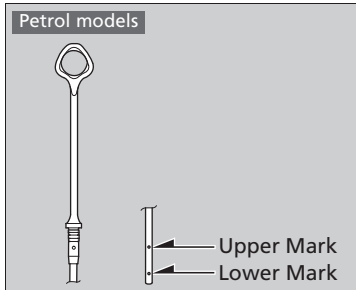

4. Remove the dipstick again, and check the level. It should be between the upper and lower marks. Add oil if necessary.

Adding Engine Oil

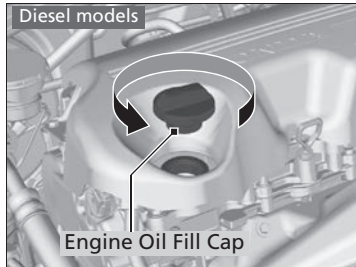
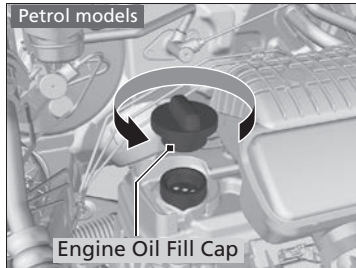

1. Unscrew and remove the engine oil fill cap.
2. Add oil slowly.
3. Reinstall the engine oil fill cap, and tighten it securely.
4. Wait for three minutes and recheck the engine oil dipstick.

►► Adding Engine Oil

NOTICE

Do not fill the engine oil above the upper mark. Overfilling the engine oil can result in leaks and engine damage.

If any oil spills, wipe it away immediately. Spilled oil may damage the engine compartment components.

Engine Coolant

Specified coolant: Honda All Season Antifreeze/Coolant Type 2

Petrol models

This coolant is premixed with 40% antifreeze and 60% water. Do not add any straight antifreeze or water.

Diesel models

This coolant is premixed with 50% antifreeze and 50% water. Do not add any straight antifreeze or water.

We recommend you check the engine coolant level every time you refuel. Check the reserve tank first. If it is completely empty, also check the coolant level in the radiator. Add the engine coolant accordingly.

Engine Coolant

WARNING

Removing the radiator cap while the engine is hot can cause the coolant to spray out, seriously scalding you.

Always let the engine and radiator cool down before removing the radiator cap.

If Honda antifreeze/coolant is not available, you may use another major brand of non-silicate coolant as a temporary replacement. Check that it is a high quality coolant recommended for aluminium engines. Continued use of any non-Honda coolant can result in corrosion, causing the cooling system to malfunction or fail. Have the cooling system flushed and refilled with Honda antifreeze/coolant as soon as possible.

Do not add rust inhibitors or other additives to your vehicle's cooling system. They may not be compatible with the coolant or with the engine components.

Petrol models

Reserve Tank

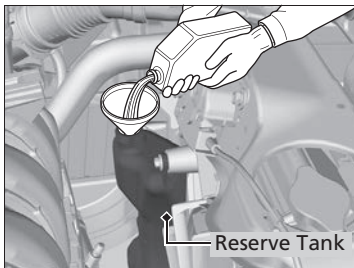
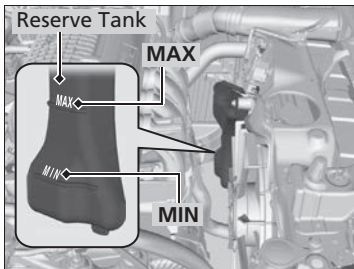

1. **Make sure the engine and radiator are cool.**
2. Check the amount of coolant in the reserve tank.
 - If the coolant level is below the **MIN** mark, add the specified coolant until it reaches the **MAX** mark.
3. Inspect the cooling system for leaks.

Continued

Diesel models

Reserve Tank

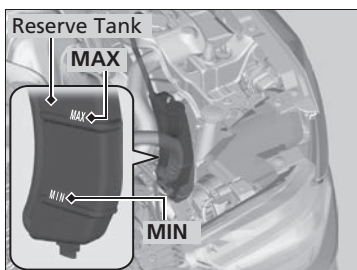

1. **Make sure the engine and radiator are cool.**
2. Check the amount of coolant in the reserve tank.
 - If the coolant level is below the **MIN** mark, add the specified coolant until it reaches the **MAX** mark.
3. Inspect the cooling system for leaks.

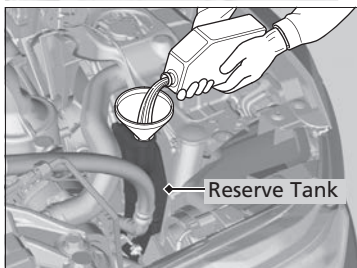

Radiator

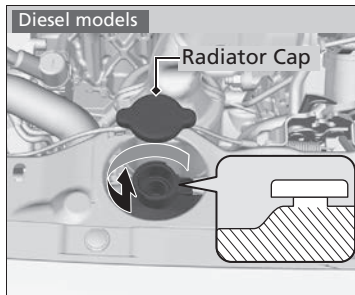
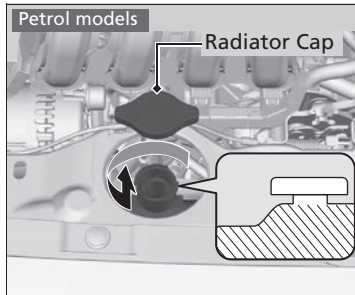

1. **Make sure the engine and radiator are cool.**
2. Turn the radiator cap 1/8 turn anticlockwise and relieve any pressure in the cooling system.
3. Push down and turn the radiator cap anticlockwise to remove it.
4. The coolant level should be up to the base of the filler neck. Add coolant if it is low.
5. Put the radiator cap back on, and tighten it fully.

►► Radiator

NOTICE

Pour the fluid slowly and carefully so you do not spill any. Clean up any spills immediately; they can damage components in the engine compartment.

Transmission Fluid

Continuously variable transmission models

Continuously Variable Transmission (CVT) Fluid

Specified fluid: Honda HCF-2 Transmission Fluid

Have a dealer check the fluid level and replace if necessary. Follow your vehicle's maintenance service timing of when to change continuously variable transmission (CVT) fluid.

➤ **Maintenance Schedule** P. 233, 236

Do not attempt to check or change the continuously variable transmission (CVT) fluid yourself.

➤ Continuously Variable Transmission (CVT) Fluid

NOTICE

Do not mix Honda HCF-2 with other transmission fluids.

Using a transmission fluid other than Honda HCF-2 may adversely affect the operation and durability of your vehicle's transmission, and damage the transmission.

Any damage caused by using a transmission fluid that is not equivalent to Honda HCF-2 is not covered by Honda's new vehicle limited warranty.

Manual transmission models

Manual Transmission Fluid**Specified fluid: Honda Manual Transmission Fluid (MTF)**

Have a dealer check the fluid level and replace if necessary.
Follow your vehicle's maintenance service timing of when to change manual transmission fluid.

➤ **Maintenance Schedule** P. 233, 236

Do not attempt to check or change the manual transmission fluid yourself.

▶▶ Manual Transmission Fluid

NOTICE**Petrol models**

If Honda MTF is not available, you may use the API certificated SAE 10W-30, 10W-40, 0W-20 or 5W-20 viscosity motor oil as a temporary measure.

Diesel models

If Honda MTF is not available, you may use the API certificated SAE 0W-20 or 5W-20 viscosity motor oil as a temporary measure.

Replace with MTF as soon as possible. Motor oil does not contain the proper additives for the transmission and continued use can cause decreased shifting performance and lead to transmission damage.

Brake/Clutch* Fluid

Specified fluid: Brake Fluid with DOT 3 or DOT 4

Use the same fluid for both the brakes and clutch.

■ Checking the Brake Fluid

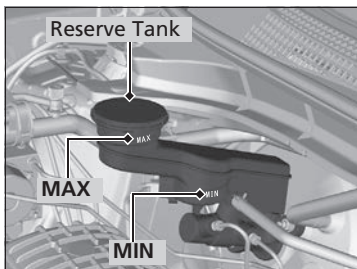

The fluid level should be between the **MIN** and **MAX** marks on the side of the reserve tank.

Manual transmission models

The brake fluid reserve tank is also used for your vehicle's clutch fluid. As long as you keep the brake fluid level as instructed above, there is no need for checking the clutch fluid level.

» Brake/Clutch* Fluid

NOTICE

Brake fluid marked DOT 5 is not compatible with your vehicle's braking system and can cause extensive damage.

We recommend using a genuine product.

If the brake fluid level is at or below the **MIN** mark, have a dealer inspect the vehicle for leaks or worn brake pads as soon as possible.

Refilling Window Washer Fluid

Check the amount of window washer fluid by looking at the reservoir.

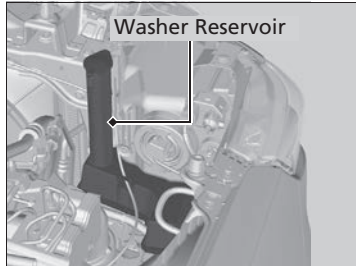

If the level is low, fill the washer reservoir.

Pour the washer fluid carefully. Do not overflow the reservoir.

► Refilling Window Washer Fluid

NOTICE

Do not use engine antifreeze or a vinegar/water solution in the washer reservoir.

Antifreeze can damage your vehicle's paint. A vinegar/water solution can damage the washer pump.

Use only commercially available washer fluid. Avoid prolonged use of hard water to prevent lime scale build up.

Replacing Light Bulbs

Headlight Bulbs

When replacing, use the following bulbs.

High/Low beam headlight: 60/55 W (H4 for halogen bulb type)

High/Low Beam Headlight

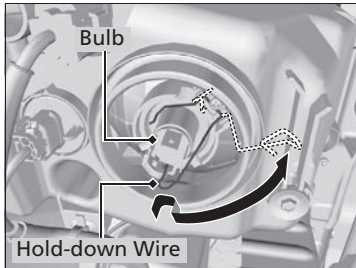
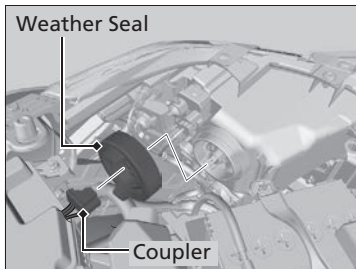

1. Remove the coupler.
 - ▶ It can be removed by pulling it straight back.
2. Remove the rubber weather seal.
3. Unclip the hold-down wire, then pivot it out of the way.
4. Remove the old bulb.
5. Insert a new bulb into the headlight assembly.
6. Clip the hold-down wire properly.
7. Install the rubber weather seal.
8. Insert the coupler into the connector of the bulb.

Headlight Bulbs

NOTICE

Halogen bulbs get very hot when lit. Oil, perspiration, or a scratch on the glass can cause the bulb to overheat and shatter.

The headlight aim is set by the factory, and does not need to be adjusted. However, if you regularly carry heavy items in the boot, have the aiming readjusted at a dealer or by a qualified technician.

When replacing a halogen bulb, handle it by its base, and protect the glass from contact with your skin or hard objects. If you touch the glass, clean it with denatured alcohol and a clean cloth.

High/Low Beam Headlight

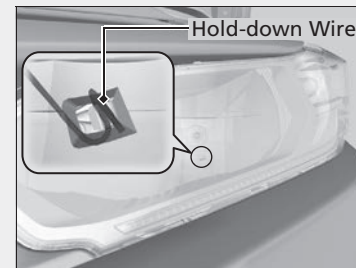

Make sure the hold-down wire is installed properly and securely. Check its installation from the inspection window.

Fog Light Bulbs*

When replacing, use the following bulbs.

Fog Light: 19 W (H16 for halogen bulb type)

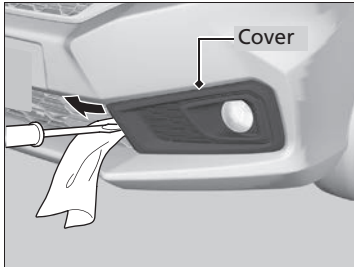

1. Pry on the edge between the bumper and the cover using a flat-tip screwdriver to remove the cover.
 - ▶ Wrap the flat-tip screwdriver with a cloth to prevent scratches.

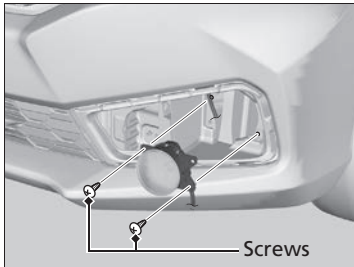

2. Remove the screws using a Phillips-head screwdriver.
3. Remove the fog light assembly.

▶▶ Fog Light Bulbs*

NOTICE

Halogen bulbs get very hot when lit. Oil, perspiration, or a scratch on the glass can cause the bulb to overheat and shatter.

When replacing a halogen bulb, handle it by its plastic case, and protect the glass from contact with your skin or hard objects. If you touch the glass, clean it with denatured alcohol and a clean cloth.

* Not available on all models

Continued

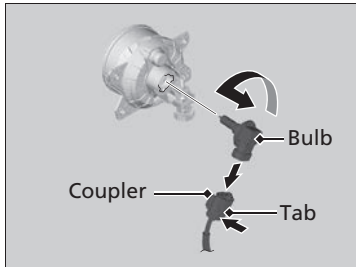

4. Push the tab to remove the coupler.
5. Rotate the old bulb to the left to remove.
6. Insert a new bulb into the fog light assembly and turn it to the right.
7. Insert the coupler into the connector of the bulb.

Front Turn Signal Light Bulbs

When replacing, use the following bulbs.

Front Turn Signal Light: 21 W (Amber)

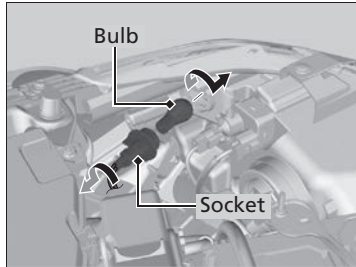

1. Turn the socket to the left and remove it.
2. Remove the old bulb and insert a new bulb.

Position Light Bulbs

When replacing, use the following bulbs.

Models with bulb type position lights

Position Light: 5 W

Models with LED type position lights

Position Light: LED

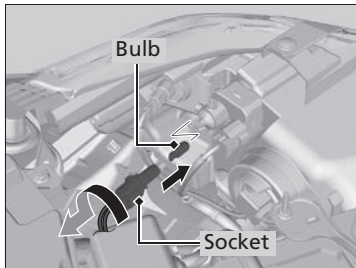

Models with bulb type position lights

1. Turn the socket to the left and remove it.
2. Remove the old bulb and insert a new bulb.

► Position Light Bulbs

Models with LED type position lights

Position lights are LED type. Have an authorised Honda dealer inspect and replace the light assembly.

Side Turn Signal/Emergency Indicator Light Bulbs

When replacing, use the following bulbs.

Fender type

Side Turn Signal Light: 5 W (Amber)

Door mirror type

Side Turn Signal Light: LED

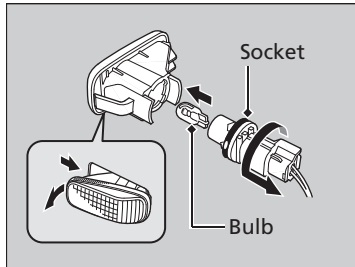

Fender type

1. Push the front of the side turn signal assembly toward the rear of the vehicle until it pops out of the body.
2. Turn the socket to the left and remove it.
3. Remove the old bulb and insert a new bulb.

▶▶ Side Turn Signal/Emergency Indicator Light Bulbs

Door mirror type

Door mirror side turn signal lights are LED type. Have an authorised Honda dealer inspect and replace the light assembly.

Brake Light, Taillight, Back-Up Light and Rear Turn Signal Light Bulbs

When replacing, use the following bulbs.

Brake Light: 21 W
Taillight: 5 W
Back-Up Light: 16 W
Rear Turn Signal Light: 21 W (Amber)

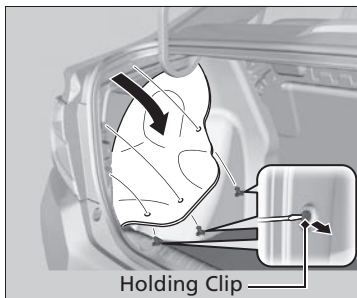

1. Remove the holding clips using a flat-tip screwdriver, then pull the lining back.

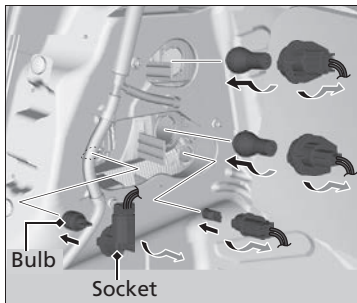

2. Turn the socket to the left and remove it.
3. Remove the old bulb and insert a new bulb.

▶▶ Brake Light, Taillight, Back-Up Light and Rear Turn Signal Light Bulbs

▶▶ Holding clip

Insert a flat-tip screwdriver, lift and remove the central pin to remove the clip.

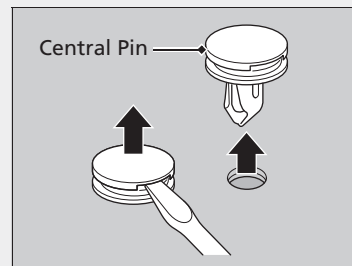

Insert the clip with the central pin raised, and push until it is flat.

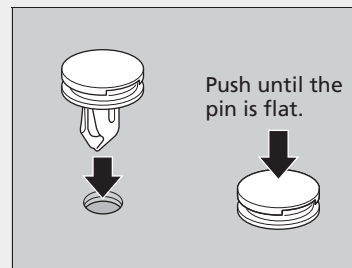

Rear Licence Plate Light Bulbs

When replacing, use the following bulbs.

Rear Licence Plate Light: 5 W

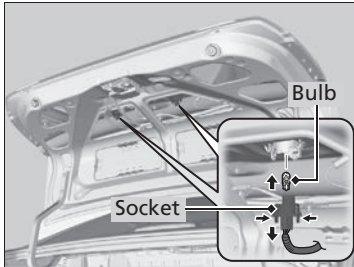

1. Remove the licence plate light assembly by squeezing the tabs on both sides of the socket.
2. Remove the old bulb and insert a new bulb.

High-Mount Brake Light Bulb

When replacing, use the following bulb.

High-Mount Brake Light: 21 W

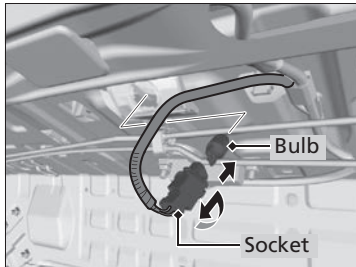

1. Open the boot.
2. Turn the socket to the left and remove it.
3. Remove the old bulb and insert a new bulb.

Other Light Bulbs

Ceiling Light Bulb

When replacing, use the following bulb.

Ceiling Light: 8 W

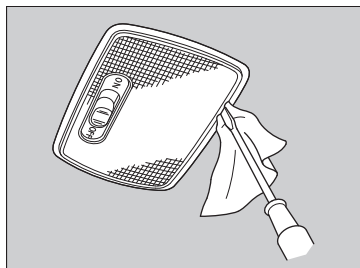

1. Pry on the edge of the cover using a flat-tip screwdriver to remove the cover.
 - ▶ Wrap the flat-tip screwdriver with a cloth to prevent scratches.

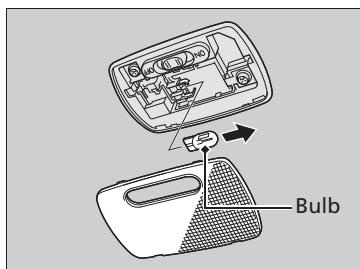

2. Remove the old bulb and insert a new bulb.

Boot Light Bulb

When replacing, use the following bulb.

Boot Light: 5 W

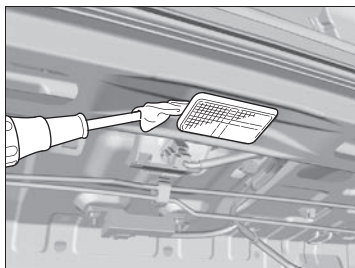

1. Pry on the edge of the cover using a flat-tip screwdriver to remove the cover.
 - ▶ Wrap the flat-tip screwdriver with a cloth to prevent scratches.

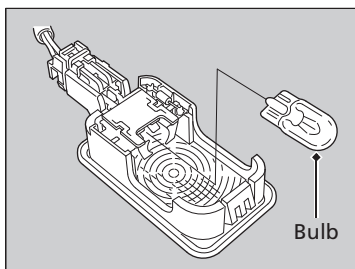

2. Remove the old bulb and insert a new bulb.

Checking and Maintaining Wiper Blades

Checking Wiper Blades

If the wiper blade rubber has deteriorated, it will leave streaks and the hard surfaces of the blade may scratch the window glass.

Changing the Wiper Blade Rubber

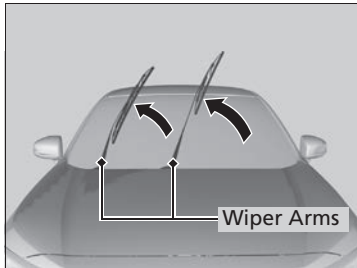

1. Lift the driver side wiper arm first, then the passenger side.

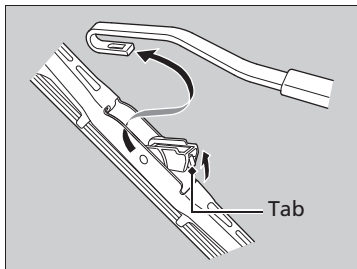

2. Press and hold the tab, then slide the holder off the wiper arm.

Changing the Wiper Blade Rubber

NOTICE

Avoid dropping the wiper arm onto the windshield, it may damage the wiper arm and/or the windshield.

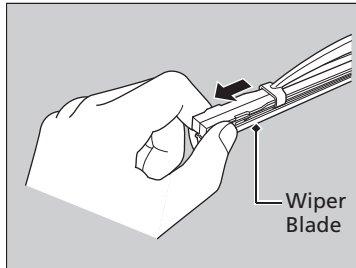

3. Slide the wiper blade out of the holder by pulling the tabbed end out.

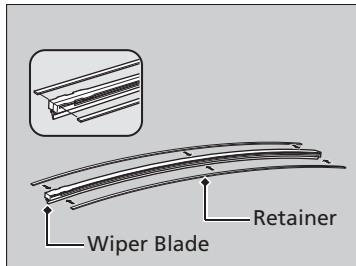

4. Remove the retainers from the wiper blade that has been removed, and mount to a new wiper blade.

▶ Correctly align the wiper blade protrusion and the retainer grooves.

5. Slide the new wiper blade onto the holder from the bottom end.

▶ The tab on the holder should fit in the indent of the wiper blade.

6. Slide the wiper blade onto the wiper arm until it locks.

7. Lower the passenger side wiper arm first, then the driver side.

Checking and Maintaining Tyres

Checking Tyres

To safely operate your vehicle, your tyres must be of the proper type and size, in good condition with adequate tread, and properly inflated.

■ Inflation guidelines

Properly inflated tyres provide the best combination of handling, tread life, and comfort. Refer to the driver's doorjamb label for the specified pressure.

Underinflated tyres wear unevenly, adversely affect handling and fuel economy, and are more likely to fail from overheating.

Overinflated tyres make your vehicle ride harshly, are more prone to road hazards, and wear unevenly.

Every day before you drive, look at each of the tyres. If one looks lower than the others, check the pressure with a tyre gauge.

At least once a month or before long trips, use a gauge to measure the pressure in all tyres, including the spare. Even tyres in good condition can lose 10-20 kPa (0.1-0.2 kgf/cm², 1-2 psi) per month.

■ Inspection guidelines

Every time you check inflation, also examine the tyres and valve stems. Look for:

- Bumps or bulges on the side or in the tread. Replace the tyre if you find any cuts, splits, or cracks in the side of the tyre. Replace it if you see fabric or cord.
- Remove any foreign objects and inspect for air leaks.
- Uneven tread wear. Have a dealer check the wheel alignment.
- Excessive tread wear.
 - **Wear Indicators** P. 269
- Cracks or other damage around valve stem.

➤ Checking Tyres

⚠ WARNING

Using tyres that are excessively worn or improperly inflated can cause a crash in which you can be seriously hurt or killed.

Follow all instructions in this owner's manual regarding tyre inflation and maintenance.

Measure the air pressure when tyres are cold. This means the vehicle has been parked for at least three hours, or driven less than 1.6 km. If necessary, add or release air until the specified pressure is reached.

If checked when hot, tyre pressure can be as much as 30–40 kPa (0.3–0.4 kgf/cm², 4–6 psi) higher than if checked when cold.

Have a dealer check the tyres if you feel a consistent vibration while driving. New tyres and any that have been removed and reinstalled should be properly balanced.

Wear Indicators

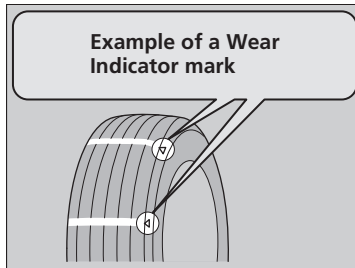

The groove where the wear indicator is located is 1.6 mm shallower than elsewhere on the tyre. If the tread has worn so that the indicator is exposed, replace the tyre. **Worn out tyres have poor traction on wet roads.**

Tyre Service Life

The life of your tyres is dependent on many factors, including driving habits, road conditions, vehicle loading, inflation pressure, maintenance history, speed, and environmental conditions (even when the tyres are not in use).

In addition to regular inspections and inflation pressure maintenance, it is recommended that you have annual inspections performed once the tyres reach five years old. All tyres, including the spare, should be removed from service after 10 years from the date of manufacture, regardless of their condition or state of wear.

Tyre and Wheel Replacement

Replace your tyres with radials of the same size, load range, speed rating, and maximum cold tyre pressure rating (as shown on the tyre's sidewall). Using tyres of a different size or construction can cause certain vehicle systems such as the ABS to work incorrectly.

It is best to replace all four tyres at the same time. If that isn't possible, replace the front or rear tyres in pairs.

Make sure that the wheel's specifications match those of the original wheels.

ⓘ Tyre and Wheel Replacement

⚠ WARNING

Installing improper tyres on your vehicle can affect handling and stability. This can cause a crash in which you can be seriously hurt or killed.

Always use the size and type of tyres recommended in the tyre information label on your vehicle.

Tyre Rotation

Rotating tyres according to the maintenance schedule helps to distribute wear more evenly and increase tyre life.

■ Your Vehicle's Tyre Rotation Pattern

Models with temporary spare tyre (175/70R14)

Rotate the tyres as shown here.

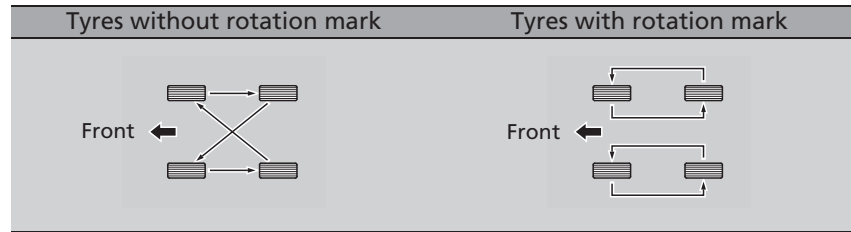

Models with full-size spare tyre (175/65R14)

Rotate the tyres, including a spare, as shown here.

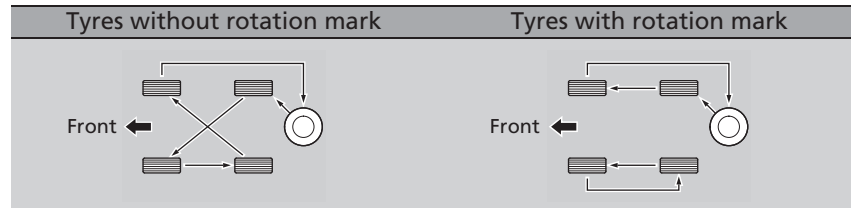

▣ Tyre Rotation

Tyres with directional tread patterns should only be rotated front to back (not from one side to the other). Directional tyres should be mounted with the rotation indication mark facing forward, as shown below.

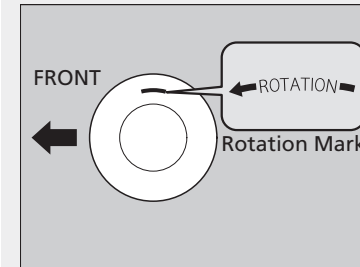

When the tyres are rotated, make sure the air pressures are checked.

Battery

Checking the Battery

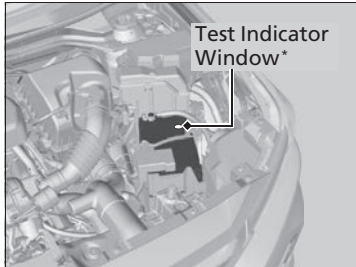

Models with test indicator window on the battery

Check the battery condition monthly. Look at the test indicator window and check the terminals for corrosion.

Models with upper and lower level marks

Check the battery condition monthly. Check the battery condition by looking at the fluid level. The upper and lower level marks are shown on the battery case. If the fluid level is below the lower mark, contact a dealer.

Models without test indicator window and upper and lower level marks

Check the battery terminals for corrosion monthly.

If your vehicle's battery is disconnected or goes dead:

- The clock resets.
➤ **Clock** P. 90

➤ Battery

⚠ WARNING

The battery gives off explosive hydrogen gas during normal operation.

A spark or open flame can cause the battery to explode with enough force to kill or seriously hurt you.

Keep all sparks, open flames, and smoking materials away from the battery.

Wear protective clothing and a face shield, or have a skilled technician do any battery maintenance.

⚠ WARNING

The battery contains sulfuric acid (electrolyte) which is highly corrosive and poisonous.

Getting electrolyte in your eyes or on your skin can cause serious burns. Wear protective clothing and eye protection when working on or near the battery.

Swallowing electrolyte can cause fatal poisoning if immediate action is not taken.

KEEP OUT OF THE REACH OF CHILDREN

Charging the Battery

Disconnect both battery cables to prevent damaging your vehicle's electrical system. Always disconnect the negative (-) cable first, and reconnect it last.

▶▶ Battery

Models with test indicator window on the battery

The test indicator's colour information is on the battery.

Emergency Procedures

Eyes: Flush with water from a cup or other container for at least 15 minutes. (Water under pressure can damage the eye.) Call a physician immediately.

Skin: Remove contaminated clothing. Flush the skin with large quantities of water. Call a physician immediately.

Swallowing: Drink water or milk. Call a physician immediately.

When you find corrosion, clean the battery terminals by applying a baking powder and water solution. Clean the terminals with a damp towel. Cloth/towel dry the battery. Coat the terminals with grease to help prevent future corrosion.

When replacing the battery, the replacement must be of the same specifications.

Consult a dealer for more information.

Remote Transmitter Care*

Replacing the Button Battery

If the indicator does not come on when the button is pressed, replace the battery.

Ignition Keys with Remote Transmitter*

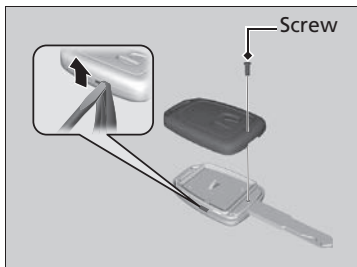

Battery type: CR1620

1. Unscrew the cover with a small Phillips-head screwdriver.
2. Open the remote transmitter.
 - ▶ Wrap a small flat-tip screwdriver with a cloth to prevent scratching the transmitter.
3. Remove the button battery with the small flat-tip screwdriver.
4. Make sure to replace the battery with the correct polarity.

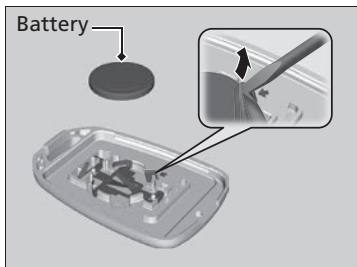

Replacing the Button Battery

⚠ WARNING

CHEMICAL BURN HAZARD

The battery that powers the remote transmitter can cause severe internal burns and can even lead to death if swallowed. Keep new and used batteries away from children.

If you suspect that a child has swallowed the battery, seek medical attention immediately.

NOTICE

An improperly disposed of battery can damage the environment. Always confirm local regulations for battery disposal.

Replacement batteries are commercially available or at a dealer.

■ Keyless Remote *



Battery type: CR2032

1. Remove the built-in key.

2. Remove the upper half of the cover by carefully prying on the edge with a coin.
 - ▶ Remove carefully to avoid losing the buttons.
 - ▶ Wrap a coin with a cloth to prevent scratching the keyless remote.
3. Make sure to replace the battery with the correct polarity.

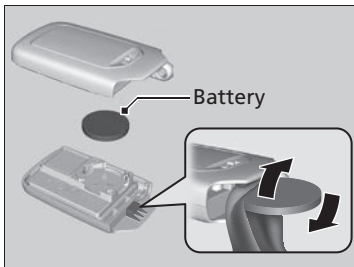

* Not available on all models

Cleaning

Interior Care

Use a vacuum cleaner to remove dust before using a cloth.

Use a damp cloth with a mixture of mild detergent and warm water to remove dirt.

Use a clean cloth to remove detergent residue.

Cleaning Seat Belts

Use a soft brush with a mixture of mild soap and warm water to clean the seat belts.

Let the belts air dry. Wipe the loops of the seat belt anchors using a clean cloth.

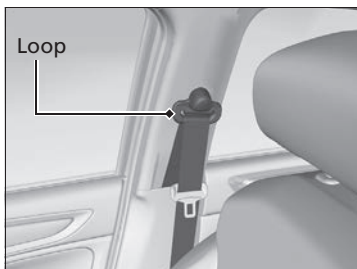

Cleaning the Window

Wipe using a glass cleaner.

Interior Care

Do not spill liquids inside the vehicle. Electrical devices and systems may malfunction if liquids are splashed on them.

Do not use silicone based sprays on electrical devices such as audio devices and switches. Doing so may cause the items to malfunction or cause a fire inside the vehicle. If a silicone based spray is inadvertently used on electrical devices, consult a dealer.

Depending on their composition, chemicals and liquid aromatics may cause discoloration, wrinkles, and cracking to resin-based parts and textiles. Do not use alkali solvents or organic solvents such as benzene or petrol.

After using chemicals, make sure to gently wipe them away using a dry cloth. Do not place used cloths on top of resin based parts or textiles for long periods of time without washing.

Be careful not to spill a liquid type air freshener.

Cleaning the Window

Models with rear demister

Wires are mounted to the inside of the rear window. Wipe along the same direction as the wires with a soft cloth so as not to damage them.

Exterior Care

Dust off the vehicle body after you drive.

Regularly inspect your vehicle for scratches on painted surfaces. A scratch on a painted surface can result in body rust. If you find a scratch, promptly repair it.

■ Washing the Vehicle

Wash the vehicle regularly. Wash more frequently when driving in the following conditions:

- If driving on roads with road salt.
- If driving in coastal areas.
- If tar, soot, bird droppings, insects, or tree sap are stuck to painted surfaces.

■ Using an Automated Car Wash

- Make sure to follow the instructions indicated on the automated car wash.
 - Fold in the door mirrors.
 - Remove the audio antenna*.
- 📖 **Audio Antenna*** P. 151

■ Using High Pressure Cleaners

- Keep sufficient distance between the cleaning nozzle and the vehicle body.
- Take particular care around the windows. Standing too close may cause water to enter the vehicle interior.
- Do not spray high pressure water directly into the engine compartment. Instead, use low pressure water and a mild detergent.

* Not available on all models

Continued

▶▶ Washing the Vehicle

Do not spray water into the air intake vents. It can cause a malfunction.

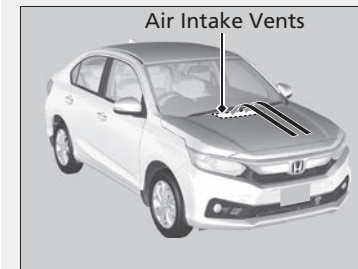

■ Applying Wax

A good coat of automotive body wax helps to protect your vehicle's paint from the elements. Wax will wear off over time and expose your vehicle's paint to the elements, so reapply as necessary.

■ Maintaining the Bumpers and Other Resin Coated Parts

If you get petrol, oil, engine coolant, or battery fluid on resin coated parts, they may be stained or the coating may peel. Promptly wipe it away using a soft cloth and clean water.

■ Cleaning the Window

Wipe using a glass cleaner.

■ Maintaining Aluminium Wheels*

Aluminium is susceptible to deterioration caused by salt and other road contaminants. When necessary, as early as possible use a sponge and mild detergent to wipe away these contaminants. Do not use a stiff brush or harsh chemicals (including some commercial wheel cleaners). These can damage the protective finish on aluminium alloy wheels, resulting in corrosion. Depending on the type of finish, the wheels also may lose their luster or appear burnished. To avoid water stains, wipe the wheels dry with a cloth while they are still wet.

► Applying Wax

NOTICE

Chemical solvents and strong cleaners can damage the paint, metal, and plastic on your vehicle. Wipe away spills immediately.

► Maintaining the Bumpers and Other Resin Coated Parts

Ask a dealer about the correct coating material when you want to repair the painted surface of the parts made of resin.

■ Fogged Exterior Light Lenses

The inside lenses of exterior lights (headlights, brake lights, etc.) may fog temporarily if you have driven in the rain, or after the vehicle has been run through a car wash. Dew condensation also may build up inside the lenses when there is a significant enough difference between the ambient and inside lens temperatures (similar to vehicle windows fogging up in rainy conditions). These conditions are natural processes, not structural design problems in the exterior lights.

Lens design characteristics may result in moisture developing on the light lens frame surfaces. This also is not a malfunction.

However, if you see large amounts of water accumulation, or large water drops building up inside the lenses, have your vehicle inspected by a dealer.

Accessories

When installing accessories, check the following:

- Do not install accessories on the windshield. They can obstruct your view and delay your reaction to driving conditions.
- Be sure that electronic accessories do not overload electrical circuits or interfere with proper operation of your vehicle.
 - **Fuses** P. 303
- Before installing any electronic accessory, have the installer contact a dealer for assistance. If possible, have a dealer inspect the final installation.

Modifications

Do not modify your vehicle in a manner that may affect its handling, stability, or reliability, or install non-genuine Honda parts or accessories that may have a similar effect.

Even minor modifications to vehicle systems can affect overall vehicle performance. Always make sure all equipment is properly installed and maintained, and do not make any modification to your vehicle or its systems that might cause your vehicle to no longer meet your country's and local regulations.

The on-board diagnostic port (OBD-II/SAE J1962 connector) installed on this vehicle is intended to be used with automobile system diagnostic devices or with other devices that Honda has approved. Use of any other type of device may adversely affect the vehicle's electronic systems or allow them to be compromised, possibly resulting in a system malfunction, drained battery, or other unexpected problems.

Do not modify or attempt to repair any of the electrical components.

Accessories and Modifications

⚠ WARNING

Improper accessories or modifications can affect your vehicle's handling, stability, and performance, and cause a crash in which you can be seriously hurt or killed.

Follow all instructions in this owner's manual regarding accessories and modifications.

When properly installed, mobile phones, alarms, two-way radios, radio antennas, and low-powered audio systems should not interfere with your vehicle's computer controlled systems, such as your airbags and anti-lock brakes.

Honda Genuine accessories are recommended to ensure proper operation on your vehicle.

Handling the Unexpected

This chapter explains how to handle unexpected troubles.

Tools	
Types of Tools.....	282
If a Tyre Goes Flat	
Changing a Flat Tyre.....	283
Engine Does Not Start	
Checking the Engine.....	290
Models with keyless access system	
If the Keyless Remote Battery is Weak	292
Models with keyless access system	
Emergency Engine Stop	293
Jump Starting	294
Shift Lever Does Not Move	297

Overheating	
How to Handle Overheating.....	298
Indicator, Coming On/Blinking	
If the Low Oil Pressure Indicator Comes On	300
If the Charging System Indicator Comes On	300
If the Malfunction Indicator Lamp Comes On or Blinks	301
If the Brake System Indicator (Red) Comes On	301

If the Electric Power Steering (EPS) System Indicator Comes On	302
Diesel models	
If the PGM-FI Indicator Comes On.....	302
Fuses	
Fuse Locations	303
Inspecting and Changing Fuses.....	309
Emergency Towing	310

Tools

Types of Tools

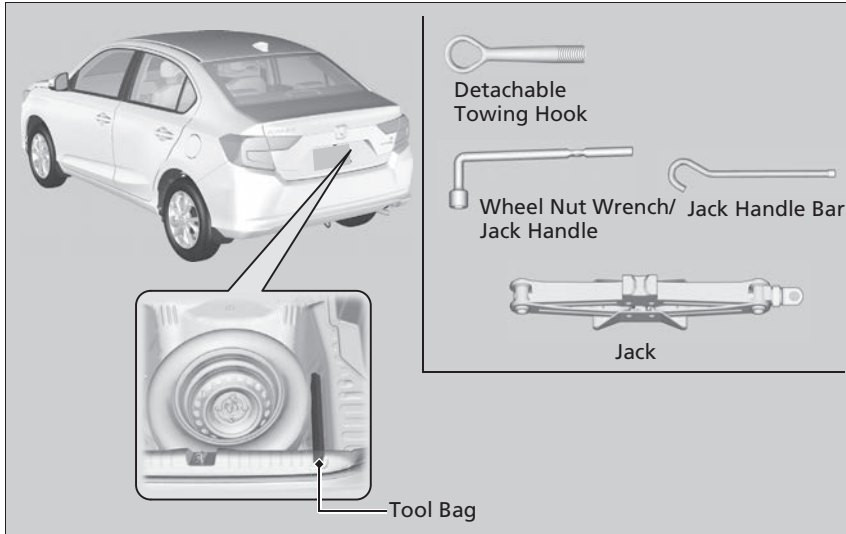

Types of Tools

The tools are stored in the boot.

If a Tyre Goes Flat

Changing a Flat Tyre

If a tyre goes flat while driving, grasp the steering wheel firmly, and brake gradually to reduce speed. Then, stop in a safe place. Replace the flat tyre with a temporary spare tyre*/full-size spare tyre*(Steel Type): Go to a dealer as soon as possible to have the full size tyre repaired or replaced.

1. Park the vehicle on firm, level, non-slippery surface and apply the parking brake.

Continuously variable transmission models

2. Move the shift lever to **P**.

Manual transmission models

2. Move the shift lever to **R**.

All models

3. Turn on the hazard warning lights and turn the ignition switch to LOCK **O***1.

*1: Models with the keyless access system have an **ENGINE START/STOP** button instead of an ignition switch.

* Not available on all models

Changing a Flat Tyre

Models with temporary spare tyre

Follow temporary spare precautions:

Check the air pressure of the 175/70R14 size temporary spare tyre every time you check the other full-size tyres. It should be inflated to the recommended air pressure on the label attached to the driver's doorjamb.

When driving with the temporary spare tyre, keep the vehicle speed under 120 km/h. Replace with a full-size tyre as soon as possible.

The temporary spare tyre and wheel in your vehicle are specifically for this model.

Do not use them with another vehicle.

Do not use another type of temporary spare tyre or wheel with your vehicle.

Do not use more than one temporary spare tyre at the same time.

Continued

■ Getting Ready to Replace the Flat Tyre

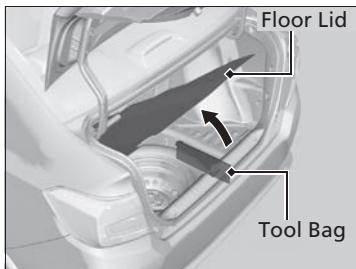

1. Open the boot floor lid.
2. Take the jack, jack handle bar and wheel nut wrench out of the tool bag.
3. Unscrew the wing bolt, and remove the spacer cone. Then, remove the spare tyre.

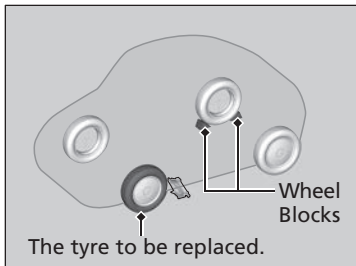

4. Place a wheel block or rock in front and rear of the wheel diagonal to the flat tyre.

✕ Changing a Flat Tyre

WARNING: The jack can only be used for helping an emergency vehicle breakdown, not for changing the regular seasonal tyre or any other normal maintenance or repair operation.

NOTICE

Do not use the jack if it doesn't work properly. Call your dealer or a professional towing service.

✕ Getting Ready to Replace the Flat Tyre

Be careful not to hurt yourself when removing or storing the spare tyre.

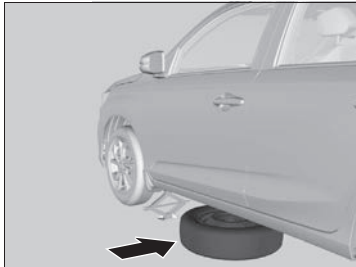

5. Place the spare tyre (wheel side up) under the vehicle body, near the tyre that needs to be replaced.

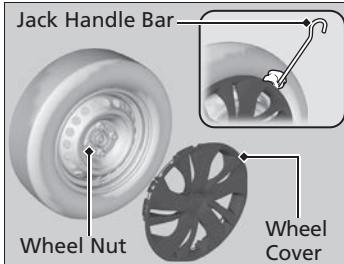

Models with wheel cover

6. Put the flat tip of the jack handle bar into the edge of the wheel cover. Carefully pry the edge and remove the cover.
 - Wrap a cloth around the flat tip of the jack handle bar to prevent scratches on the cover.

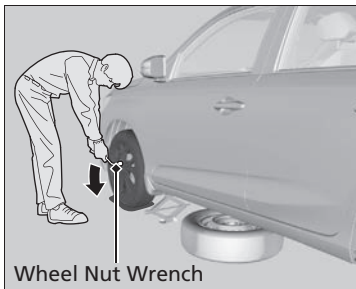

All models

7. Loosen each wheel nut about one turn using the wheel nut wrench.

How to Set Up the Jack

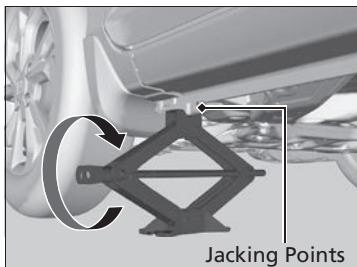
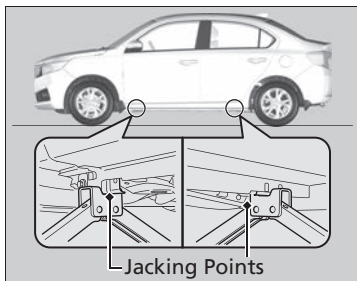

1. Place the jack under the jacking point closest to the tyre to be changed.

2. Turn the end bracket clockwise as shown in the image until the top of the jack contacts the jacking point.

▶ Make sure that the jacking point tab is resting in the jack notch.

How to Set Up the Jack

⚠ WARNING

The vehicle can easily roll off the jack, seriously injuring anyone underneath.

Follow the directions for changing a tyre exactly, and no person should place any portion of their body under a vehicle that is supported by a jack.

WARNING: The jack shall be placed on a flat and stable surface on the same level as the vehicle is parked.

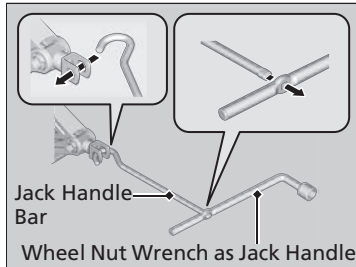

3. Raise the vehicle, using the jack handle bar and the jack handle, until the tyre is off the ground.

How to Set Up the Jack

Do not use the jack with people or luggage in the vehicle.

Use the jack provided in your vehicle. Other jacks may not support the weight ("load") or may not fit the jacking point.

The following instructions must be followed to use the jack safely:

- Do not use while the engine is running.
- Use only where the ground is firm and level.
- Use only at the jacking points.
- Do not get in the vehicle while using the jack.
- Do not put anything on top of or underneath the jack.

■ Replacing the Flat Tyre



1. Remove the wheel nuts and flat tyre.

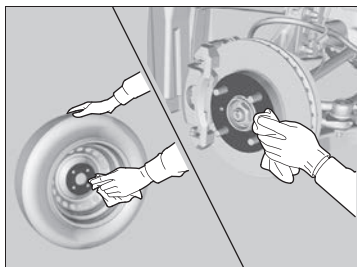

2. Wipe the mounting surfaces of the wheel with a clean cloth.

3. Mount the spare tyre.

4. Screw the wheel nuts until they touch the lips around the mounting holes, then stop rotating.

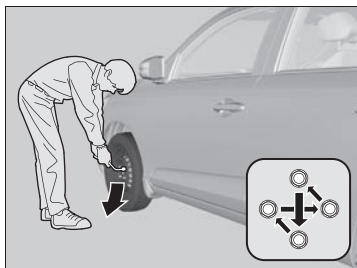

5. Lower the vehicle and remove the jack. Tighten the wheel nuts in the order indicated in the image. Go around, tightening the nuts, two to three times in this order.

Wheel nut torque:

108 N·m (11 kgf·m, 80 lbf·ft)

▣ Replacing the Flat Tyre

Do not over tighten the wheel nuts by applying extra torque using your foot or a pipe.

Models with wheel cover

Align the valve mark on the wheel cover to the tyre valve on the wheel, then install the wheel cover.

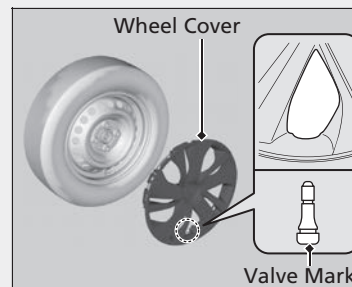

■ Storing the Flat Tyre

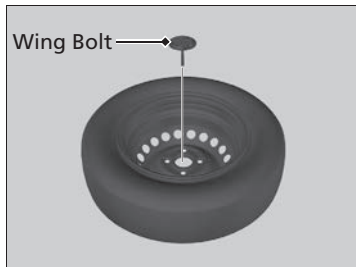
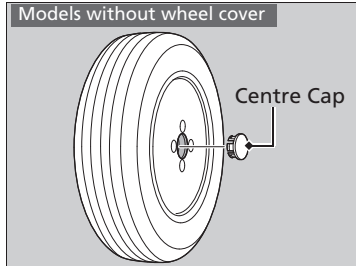

Models without wheel cover

1. Remove the centre cap.

All models

2. Place the flat tyre face down in the spare tyre well.
3. Secure the flat tyre with the wing bolt.
4. Securely store the jack, wheel nut wrench and jack handle bar back in the tool bag. Store the bag in the boot.

►► Storing the Flat Tyre

⚠ WARNING

Loose items can fly around the interior in a crash and can seriously injure the occupants.
Store the wheel, jack, and tools securely before driving.

Engine Does Not Start

Checking the Engine

If the engine does not start, check the starter.

☞ Checking the Engine

If you must start the vehicle immediately, use an assisting vehicle or booster battery to jump start it.

☞ **Jump Starting** P. 294

Handling the Unexpected

Starter condition	Checklist
<p>Starter doesn't turn or turns over slowly. The battery may be dead. Check each of the items on the right and respond accordingly.</p>	<p>Check the brightness of the interior lights. Turn on the interior lights and check the brightness.</p> <ul style="list-style-type: none">• If the interior lights are dim or do not come on at all ☞ Checking the Battery P. 272• If the interior lights come on normally ☞ Fuses P. 303 <p>Models with keyless access system</p> <ul style="list-style-type: none">• Make sure the keyless remote is in its operating range. ☞ ENGINE START/STOP Button Operating Range P. 112
<p>The starter turns over normally but the engine doesn't start. There may be a problem with the fuse. Check each of the items on the right and respond accordingly.</p>	<p>Review the engine start procedure. Follow its instructions, and try to start the engine again. ☞ Starting the Engine P. 197, 199</p> <p>Check the immobilizer system indicator. When the immobilizer system indicator is blinking, the engine cannot be started. ☞ Immobilizer System P. 108</p> <p>Check the fuel level. There should be enough fuel in the tank. ☞ Fuel Gauge P. 86</p> <p>Check the fuse. Check all fuses, or have the vehicle checked by a dealer. ☞ Inspecting and Changing Fuses P. 309</p> <p>If the problem continues: ☞ Emergency Towing P. 310</p>

Starter condition	Checklist
<p>The starter turns over normally but the engine doesn't start. There may be a problem with the fuses. Check each of the items on the right and respond accordingly.</p>	<p>Diesel models</p> <p>Have the fuel filter checked to drain off water. The water in fuel indicator comes on in the instrument panel.</p> <p>➤ Water in Fuel Indicator* P. 78</p>

* Not available on all models

Models with keyless access system

If the Keyless Remote Battery is Weak

If the beeper sounds, the **ENGINE START/STOP** button flashes, and the engine won't start, start the engine as follows:

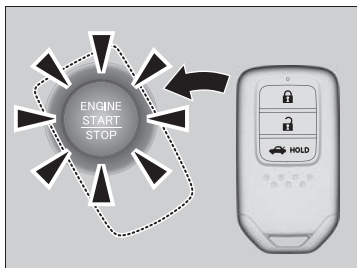

1. Touch the centre of the **ENGINE START/STOP** button with the **H** logo on the keyless remote while the **ENGINE START/STOP** button is flashing. The buttons on the keyless remote should be facing you.
 - ▶ The **ENGINE START/STOP** button flashes for about 30 seconds.

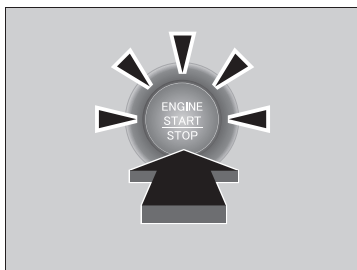

2. Depress the brake pedal and press the **ENGINE START/STOP** button within 10 seconds after the beeper sounds and the **ENGINE START/STOP** button changes from flashing to on.
 - ▶ If you do not depress the brake pedal, the mode will change to **ACCESSORY**.

Models with keyless access system

Emergency Engine Stop

The **ENGINE START/STOP** button may be used to stop the engine due to an emergency situation even while driving. If you must stop the engine, do either of the following operations:

- Press and hold the **ENGINE START/STOP** button for about two seconds.
- Firmly press the **ENGINE START/STOP** button three times.

The steering wheel will not lock.

Continuously variable transmission models

The power mode is in ACCESSORY when the engine is stopped.

To change the mode to VEHICLE OFF, move the shift lever to **P** after the vehicle comes to a complete stop. Then press the **ENGINE START/STOP** button twice without depressing the brake pedal.

Manual transmission models

The power mode changes to VEHICLE OFF.

Emergency Engine Stop

Do not press the button while driving unless it is absolutely necessary for the engine to be turned off.

Jump Starting

Jump Starting Procedure

Turn off the power to electric devices, such as audio and lights. Turn off the engine, then open the bonnet.

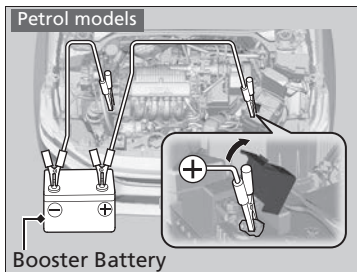

1. Open the cover on the battery ⊕ terminal.
2. Connect the first jumper cable to your vehicle's battery ⊕ terminal.
3. Connect the other end of the first jumper cable to the booster battery ⊕ terminal.
 - ▶ Use a 12-volt booster battery only.
 - ▶ When using the automotive battery charger to boost your 12-volt battery, select a lower charging voltage than 15-volt. Check the charger manual for the proper setting.

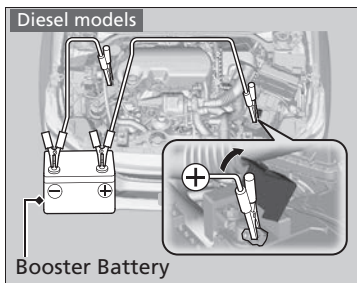

4. Connect the second jumper cable to the booster battery ⊖ terminal.

Jump Starting

⚠ WARNING

A battery can explode if you do not follow the correct procedure, seriously injuring anyone nearby.

Keep all sparks, open flames, and smoking materials away from the battery.

NOTICE

If a battery sits in extreme cold, the electrolyte inside can freeze. Attempting to jump start with a frozen battery can cause it to rupture.

Securely attach the jumper cables clips so that they do not come off when the engine vibrates. Also be careful not to tangle the jumper cables or allow the cable ends to touch each other while attaching or detaching the jumper cables.

Battery performance degrades in cold conditions and may prevent the engine from starting.

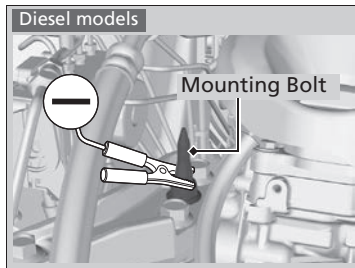
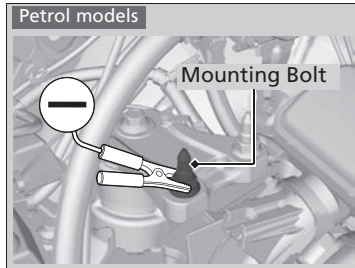

5. Connect the other end of the second jumper cable to the mounting bolt as shown. Do not connect this jumper cable to any other part.
6. If your vehicle is connected to another vehicle, start the assisting vehicle's engine and increase its rpm slightly.
7. Attempt to start your vehicle's engine. If it turns over slowly, check that the jumper cables have good metal-to-metal contact.

■ What to Do After the Engine Starts

Once your vehicle's engine has started, remove the jumper cables in the following order.

1. Disconnect the jumper cable from your vehicle's mounting bolt.
2. Disconnect the other end of the jumper cable from the booster battery \ominus terminal.
3. Disconnect the jumper cable from your vehicle's battery \oplus terminal.
4. Disconnect the other end of the jumper cable from the booster battery \oplus terminal.

Have your vehicle inspected by a nearby service station or a dealer.

Shift Lever Does Not Move

Continuously variable transmission models

Follow the procedure below if you cannot move the shift lever out of the **P** position.

Releasing the Lock

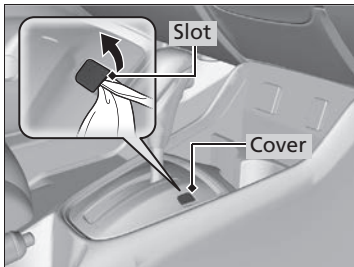

1. Set the parking brake.

Models without keyless access system

2. Remove the key from the ignition switch.

Models with keyless access system

2. Remove the built-in key from the keyless remote.

All models

3. Wrap a cloth around the tip of a small flat-tip screwdriver. Put it into the slot as shown in the image, and remove the cover.

4. Insert the key into the shift lock release slot.
5. While pushing the key down, press the shift lever release button and place the shift lever into **N**.

► The lock is now released. Have the shift lever checked by a dealer as soon as possible.

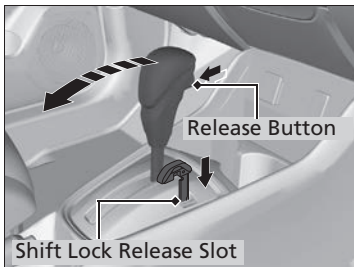

Overheating

How to Handle Overheating

Overheating symptoms are as follows:

- The high temperature indicator comes on or the engine suddenly loses power.
- Steam or spray comes out of the engine compartment.

■ First thing to do

1. Immediately park the vehicle in a safe place.
2. Turn off all accessories and turn on the hazard warning lights.
 - ▶ **No steam or spray present:** Keep the engine running and open the bonnet.
 - ▶ **Steam or spray is present:** Turn off the engine and wait until it subsides. Then open the bonnet.

How to Handle Overheating

⚠ WARNING

Steam and spray from an overheated engine can seriously scald you.

Do not open the bonnet if steam is coming out.

NOTICE

Continuing to drive with the high temperature indicator on may damage the engine.

■ Next thing to do

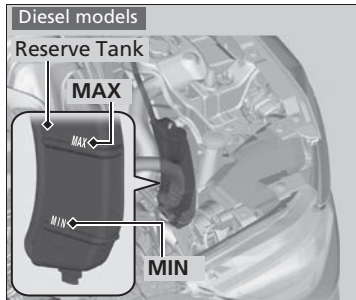
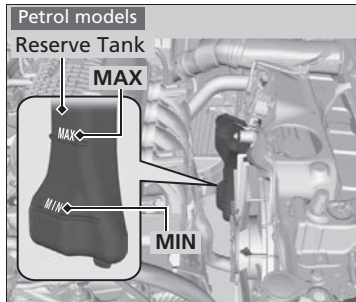

■ Last thing to do

Once the engine has cooled sufficiently, restart it and check the high temperature indicator.
If the high temperature indicator is off, resume driving. If it stays on, contact a dealer for repairs.

1. Check that the cooling fan is operating and stop the engine once the high temperature indicator goes off.
 - If the cooling fan is not operating, immediately stop the engine.
2. Once the engine has cooled down, inspect the coolant level and check the cooling system components for leaks.
 - If the coolant level in the reserve tank is low, add coolant until it reaches the **MAX** mark.
 - If there is no coolant in the reserve tank, check that the radiator is cool. Cover the radiator cap with a heavy cloth and open the cap. If necessary, add coolant up to the base of the filler neck, and put the cap back on.

►► How to Handle Overheating

⚠ WARNING

Removing the radiator cap while the engine is hot can cause the coolant to spray out, seriously scalding you.

Always let the engine and radiator cool down before removing the radiator cap.

If the coolant is leaking, contact a dealer for repairs.

Use water as an emergency/temporary measure only. Have a dealer flush the system with proper antifreeze as soon as possible.

Indicator, Coming On/Blinking

If the Low Oil Pressure Indicator Comes On



■ Reasons for the indicator to come on

Comes on when the engine oil pressure is low.

■ What to do as soon as the indicator comes on

1. Immediately park the vehicle on level ground in a safe place.
2. If necessary, turn the hazard warning lights on.

■ What to do after parking the vehicle

1. Stop the engine and let it sit for approximately three minutes.
2. Open the bonnet and check the oil level.
 - 🔧 **Oil Check** P. 245
3. Start the engine and check the low oil pressure indicator.
 - ▶ The indicator goes off: Start driving again.
 - ▶ The indicator does not go off within 10 seconds: Immediately stop the engine and contact a dealer for repairs.

If the Charging System Indicator Comes On



■ Reasons for the indicator to come on

Comes on when the battery is not being charged.

■ What to do when the indicator comes on

Turn off the heating and cooling system*/climate control system*, rear demister*, and other electrical systems, and immediately contact a dealer for repairs.

🔍 If the Low Oil Pressure Indicator Comes On

NOTICE

Running the engine with low oil pressure can cause serious mechanical damage almost immediately.

🔍 If the Charging System Indicator Comes On

If you need to stop temporarily, do not turn off the engine. Restarting the engine may rapidly discharge the battery.

If the Malfunction Indicator Lamp Comes On or Blinks



■ Reasons for the indicator lamp to come on or blink

- Comes on when there is a problem with the engine emissions control system.
- Blinks when engine misfiring is detected.

■ What to do when the indicator lamp comes on

Avoid high speeds and immediately get your vehicle inspected at a dealer.

■ What to do when the indicator lamp blinks

Park the vehicle in a safe place with no flammable items and wait at least 10 minutes or more with the engine stopped until it cools.

▶▶ If the Malfunction Indicator Lamp Comes On or Blinks

NOTICE

If you drive with the malfunction indicator lamp on, the emissions control system and the engine could be damaged.

If the malfunction indicator lamp blinks again when restarting the engine, drive to the nearest dealer at 50 km/h or less. Have your vehicle inspected.

If the Brake System Indicator (Red) Comes On



■ Reasons for the indicator to come on

- The brake fluid is low.
- There is a malfunction in the brake system.

■ What to do when the indicator comes on while driving

Depress the brake pedal lightly to check pedal pressure.

- If normal, check the brake fluid level the next time you stop.
- If abnormal, take immediate action. If necessary, downshift the transmission to slow the vehicle using engine braking.

▶▶ If the Brake System Indicator (Red) Comes On

Have your vehicle repaired immediately. It is dangerous to drive with low brake fluid. If there is no resistance from the brake pedal, stop immediately in a safe place. If necessary downshift the gears.

If the brake system indicator and **ABS** indicator come on simultaneously, the electronic brake distribution system is not working. This can result in vehicle instability under sudden braking. Have your vehicle inspected by a dealer immediately.

If the Electric Power Steering (EPS) System Indicator Comes On



■ Reasons for the indicator to come on

- Comes on when there is a problem with the EPS system.
- If you depress the accelerator pedal repeatedly to increase the engine speed while the engine is idling, the indicator comes on, and sometimes the steering wheel becomes harder to operate.

■ What to do when the indicator comes on

Stop the vehicle in a safe place and restart the engine.

If the indicator comes on and stays on, immediately have your vehicle inspected by a dealer.

Diesel models

If the PGM-FI Indicator Comes On



■ Reasons for the indicator to come on while the engine is running

There is a problem with the engine control system.

■ What to do when the indicator comes on repeatedly

Avoid full-throttle acceleration and high speed driving. Have your vehicle checked by a dealer.

▶▶ If the PGM-FI Indicator Comes On

NOTICE

Continuously driving with this indicator on can damage the emissions controls and engine. Those repairs may not be covered by your vehicle's warranties.

Fuses

Fuse Locations

If any electrical devices are not working, turn the ignition switch to LOCK [0]*1 and check to see if any applicable fuse is blown.

Engine Compartment Fuse Box A

Located in the back of the engine compartment on the left side. Push the tabs to open the box.

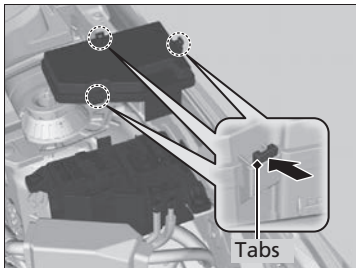

Locate the fuse in question by the fuse number in the image and chart.

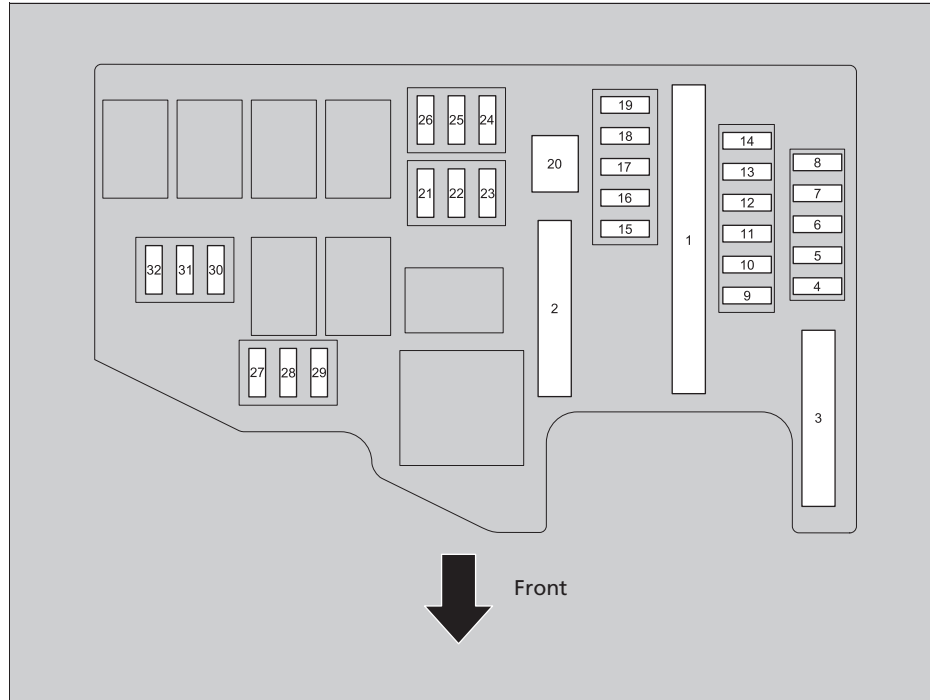

Handling the Unexpected

*1: Models with the keyless access system have an **ENGINE START/STOP** button instead of an ignition switch.

■ Circuit protected for each fuse

	Circuit Protected	Amps
1	–	–
	ST CUT*	(30 A)
	RR DEF*	(20 A)
	HTR MTR	30 A
	EPS	60 A
	F/Box Main 1	60 A
	F/Box Main 2	60 A
2	IG MAIN	30 A* ¹ 50 A* ²
	–	–
	–	–
3	IG MAIN 2*	(30 A)
	ABS MTR	40 A
	–	–
	Glow*	(60 A)
4	H/L Lo Main	20 A
5	L H/L Hi	10 A
6	R H/L Hi	10 A
7	Wiper	30 A
8	TCU*	(15 A)
9	Hazard	10 A
10	Horn	10 A
11	LAF*	(10 A)
12	ABS FSR	30 A
13	Back Up FI ECU*	(7.5 A)

	Circuit Protected	Amps
14	Stop	10 A
15	Back Up	7.5 A
16	Back Up Audio	10 A
17	MG Clutch	7.5 A
18	FR Fog*	(10 A)
19	RAD FAN	30 A
20	–	–
21	F CAN H*	(10 A)
22	F CAN L*	(10 A)
23	STS*	(7.5 A)
24	–	–
25	–	–
	–* ¹	–
26	ST MG DIODE 1* ³	7.5 A
	ST MG DIODE 2* ⁴	7.5 A
27	R H/L Lo	10 A
28	L H/L Lo	10 A
29	STRLD*	(7.5 A)
30	F CAN H*	(10 A)
31	F CAN L*	(10 A)
32	–	–

- *1: Models with keyless access system
- *2: Models without keyless access system
- *3: Continuously variable transmission models without keyless access system
- *4: Manual transmission models without keyless access system

■ Engine Compartment Fuse Box B

Located near the ⊕ terminal on the battery. Open the cover on the battery ⊕ terminal as shown in the image.

Locate the fuse in question by the following image and table.

Replacement of this fuse box should be done by a dealer.

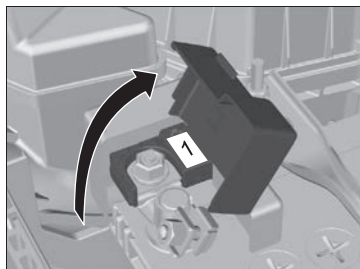

■ Circuit protected and fuse rating

	Circuit Protected	Amps
1 	Battery	100 A

Interior Fuse Box A

Located under the dashboard.

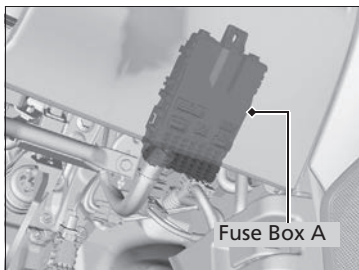

Locate the fuse in question by the fuse number in the image and chart.

Handling the Unexpected

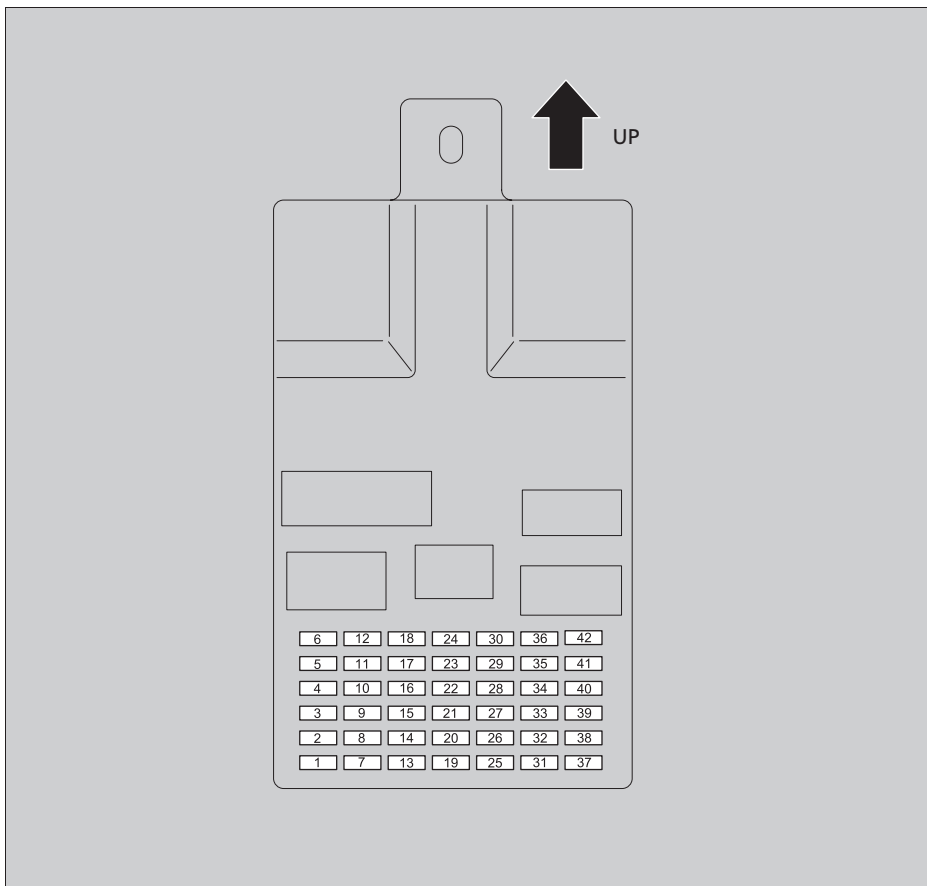

■ Circuit protected for each fuse

	Circuit Protected	Amps
1	R Side Door Lock	10 A
2	L Side Door Lock	10 A
3	ACC Key Lock	7.5 A
4	ACC Socket	20 A
5	IG2 HAC	7.5 A
6	–	–
7	IG1 SRS	10 A
8	IG1 ST CUT RLY*	(7.5 A)
9	IG1 ABS	7.5 A
10	IG1 Fuel Pump* ¹	15 A
	IG1* ²	7.5 A
11	P/W RR R	20 A
12	P/W RR L	20 A
13	IGP2*	(7.5 A)
14	IG1 FI ECU*	(7.5 A)
15	IG1 MISS SOL*	(10 A)
16	IG1 ACG	10 A
17	–	–
18	P/W AS	20 A
19	R Side Door Unlock	10 A
20	L Side Door Unlock	10 A
21	–	–
22	IG1 P/W	7.5 A
23	–	–
24	IG1 Back LT	10 A

* Not available on all models

	Circuit Protected	Amps
25	IG1 Meter	7.5 A
26	IG1 FR Wiper	7.5 A
27	IGP LAF*	(7.5 A)
28	–	–
29	D/L Main	20 A
30	P/W DR	20 A
31	DBW*	(15 A)
32	–	–
33	–	–
34	Small	10 A
35	IGP	15 A* ¹ 20 A* ²
36	IGN Coil* ¹	15 A
	ECU 2* ²	15 A
37	Smart*	(10 A)
38	–	–
39	RR ACC Socket	20 A
40	–	–
41	–	–
42	Washer	15 A

*1: Petrol models

*2: Diesel models

■ Interior Fuse Box B*

Located under the dashboard and near the fuse box A.

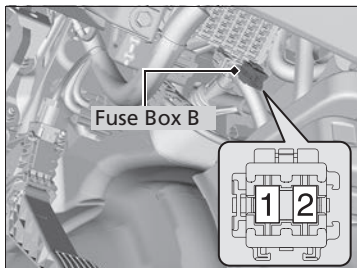

Locate the fuse in question by the fuse number in the image and chart.

■ Circuit protected and fuse rating

	Circuit Protected	Amps
1	BLOWER MTR	7.5 A
2	–	–

Inspecting and Changing Fuses

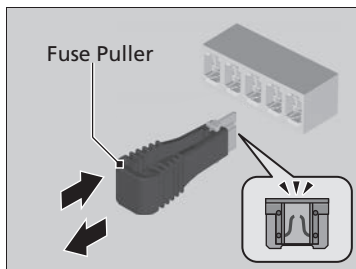
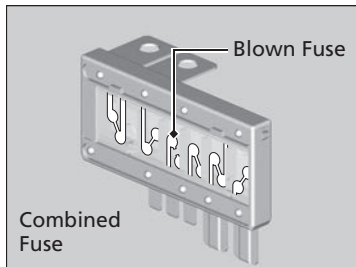
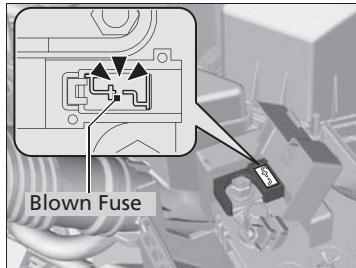

1. Turn the ignition switch to LOCK [0]*1. Turn headlights and all accessories off.
2. Open the cover on the battery ⊕ terminal.
3. Check the fuse in the engine compartment fuse box B.
 - If the fuse is blown, have it replaced by a dealer.
4. Open the fuse box cover in the engine compartment fuse box A.
5. Check the large fuse in the engine compartment fuse box A.
 - If the fuse is blown, use a Phillips-head screwdriver to remove the screw and replace it with a new one.
6. Inspect the small fuses in the engine compartment fuse box A and the vehicle interior.
 - If there is a blown fuse, remove it with the fuse puller and replace it with a new one.

*1: Models with the keyless access system have an **ENGINE START/STOP** button instead of an ignition switch.

► Inspecting and Changing Fuses

NOTICE

Replacing a fuse with one that has a higher rating greatly increases the chances of damaging the electrical system.

Replace fuse with a spare fuse of the same specified amperage.

Use the charts to locate the fuse in question and confirm the specified amperage.

► **Fuse Locations** P. 303

There is a fuse puller on the back of the engine compartment fuse box cover.

Emergency Towing

Call a professional towing service if you need to tow your vehicle.

■ Flat bed equipment

The operator loads your vehicle on the back of a truck.

This is the best way to transport your vehicle.

■ Wheel lift equipment

The tow truck uses two pivoting arms that go under the front tyres and lift them off the ground. The rear tyres remain on the ground. **This is an acceptable way to tow your vehicle.**

Emergency Towing

NOTICE

Trying to lift or tow your vehicle by the bumpers will cause serious damage. The bumpers are not designed to support the vehicle's weight.

Improper towing such as towing behind a motorhome or other motor vehicle can damage the transmission.

Never tow your vehicle with just a rope or chain. It is very dangerous, since ropes or chains may shift from side to side or break.

■ **If your vehicle must be towed with the front wheels on the ground:**

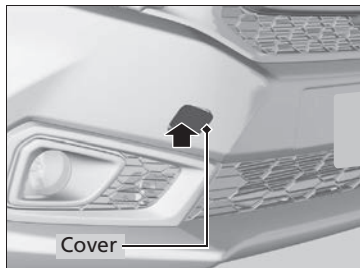

1. Check the ground underneath the vehicle around where the transmission housing is for a fluid leak.
 - ▶ If you find a leak, call a professional towing service and have your vehicle inspected by a dealer.
2. Press the left side of the cover and remove it.
 - ▶ The detachable towing hook mounts on the anchor in the front bumper.

▶ If your vehicle must be towed with the front wheels on the ground:

If you cannot follow the exact procedure, do not tow your vehicle with the front wheels on the ground.

If you cannot turn on the engine, you may experience the following while your vehicle is being towed.

- Braking may become difficult since the brake system's power assist is disabled.
- Steering wheel becomes heavy as the power steering system is disabled.

Models with keyless access system

- Check that the steering wheel is not locked.

Manual transmission models

- Turning the ignition switch to LOCK [0]*1 locks the steering wheel.

Going down a long slope heats up the brakes. This may prevent the brakes from working properly. If your vehicle needs to be towed on an incline, call a professional towing service.

Make sure to use the properly-designed and attached towing equipment.

Make sure the parking brake is released. If you cannot release the parking brake, your vehicle must be transported by the flat bed equipment.

▶ **Parking Brake** P. 217

*1: Models with the keyless access system have an **ENGINE START/STOP** button instead of an ignition switch.

Continued

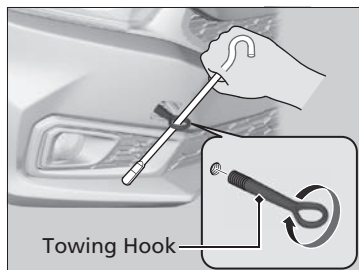

3. Take the towing hook and the wheel nut wrench out of the tool bag in the boot.
4. Screw the towing hook into the hole, and tighten it with the wheel nut wrench securely.
5. Hook the towing device to the towing hook.
6. Start the engine.
 - ▶ If it is difficult to turn on the engine, put the ignition switch in ACCESSORY **I***1 or ON **II***1.

Manual transmission models

7. Shift to **N**.

Continuously variable transmission models

7. Depress the brake pedal.
8. Shift to **D** and hold for 5 seconds, then to **N**.

All models

9. Release the parking brake.

▶ If your vehicle must be towed with the front wheels on the ground:

With the front wheels on the ground, it is best to tow the vehicle no farther than 80 km, and keep the speed below 55 km/h.

Towing a vehicle is prohibited by law in some countries. Check and follow the legal requirements of the country you are driving before towing your vehicle.

To avoid damage to your vehicle, use the towing hook for straight, flat ground towing only. Do not tow at an angle. This hook should not be used to tow the vehicle onto a flat bed. Do not use it as a tie down.

NOTICE

Continuously variable transmission models

If you cannot shift the transmission or turn on the engine, will damage the transmission. Your vehicle must be transported with the front wheels off the ground.

Manual transmission models

Do not slip the clutch for a long time to get unstuck. This may overheat and damage the transmission.

*1: Models with the keyless access system have an **ENGINE START/STOP** button instead of an ignition switch.



Information

This chapter includes your vehicle's specifications, locations of identification numbers, and other information required by regulation.

Specifications	314
Identification Numbers	
Vehicle Identification Number (VIN), Engine Number and Transmission Number	318

Specifications

Petrol models

Vehicle Specifications

Model	AMAZE	
Curb Weight	MT	905 - 924 kg
	CVT	942 - 945 kg
Maximum Permissible Weight	MT	1,360 kg
	CVT	1,380 kg

Engine Specifications

Type	Water cooled 4-stroke SOHC i-VTEC in line, 4-cylinder petrol engine	
Bore x Stroke	73.0 x 71.6 mm	
Displacement	1,199 cm ³	
Compression Ratio	10.1 : 1	
Spark Plugs	NGK	BKR6E11

Fuel

Fuel: Type	Unleaded petrol, Research octane number of 91 or higher
Fuel Tank Capacity	35 L

Battery

Capacity	27AH(5)/30AH(20)
----------	------------------

Washer Fluid

Tank Capacity	1.5 L
---------------	-------

Light Bulbs

Headlights (High/Low Beams)	60/55 W (H4)
Fog Lights *	19 W (H16)
Front Turn Signal Lights	21 W (Amber)
Position Lights	5 W * LED *
Side Turn Signal Lights (on Front Fender) *	5 W (Amber)
Side Turn Signal Lights (on Door Mirrors) *	LED
Brake Lights	21 W
Taillights	5 W
Rear Turn Signal Lights	21 W (Amber)
Back-Up Lights	16 W
High-Mount Brake Light	21 W
Rear Licence Plate Lights	5 W
Interior Lights	
Ceiling Light	8 W
Boot Light	5 W

■ Brake/Clutch* Fluid

Specified	Brake Fluid with DOT 3 or DOT 4	
-----------	---------------------------------	--

■ Continuously Variable Transmission Fluid*

Specified	Honda HCF-2 Transmission Fluid	
Capacity	Change	3.4 L

■ Manual Transmission Fluid*

Specified	Honda Manual Transmission Fluid (MTF)	
Capacity	Change	1.5 L

■ Engine Oil

Recommended	<ul style="list-style-type: none"> -Genuine Honda Green Oil -Honda Genuine Motor Oil 0W-20, 0W-30, 5W-30, 10W-30 -API service SM or higher grade or ACEA A5/B5 0W-20, 0W-30, 5W-30, 10W-30 	
	Capacity	3.0 L
	Change including filter	3.2 L

■ Engine Coolant

Specified	Honda All Season Antifreeze/Coolant Type2	
Ratio	40 (antifreeze)/60 (water) with distilled water	
Capacity* ¹	3.24 L (change including the remaining 0.42 L in the reserve tank)	
Capacity* ²	3.32 L (change including the remaining 0.42 L in the reserve tank)	

*1: Continuously variable transmission models

*2: Manual transmission models

■ Tyre

Regular	Size	175/65R14 82T* ¹
		175/65R15 84T* ²
Spare (Full-size tyre)* ¹	Pressure	See the label on driver's doorjamb.
	Size	175/65R14 82T
Temporary Spare* ²	Pressure	Same as the regular tyre. See the label on driver's doorjamb.
	Size	175/70R14 84T
Wheel Size	Pressure	See the label on driver's doorjamb.
		14 x 5J* ¹
Spare (Full-size tyre)* ¹	Regular	15 x 5J* ²
	Temporary Spare* ²	14 x 5J

*1: Models with 175/65R14 82T

*2: Models with 175/65R15 84T

Indian model only

The tyres fitted in the vehicles meet the requirement of the BIS and they comply with the requirements under the central motor vehicles rules (CMVR), 1989.

■ Brake

Type	Power assisted
Front	Disc
Rear	Drum
Parking	Hand Brake

■ Air Conditioning

Refrigerant Type	HFC-134a (R-134a)
Charge Quantity	355 - 405 g

■ Vehicle Dimensions

Length	3,995 mm	
Width	1,695 mm	
Height	1,498 mm* ¹	
	1,501 mm* ²	
Wheelbase	2,470 mm	
Track	Front	1,490 mm* ³
		1,493 mm* ⁴
	Rear	1,487 mm* ³
		1,488 mm* ⁴

*1: Models without fin antenna

*2: Models with fin antenna

*3: Models without keyless access system

*4: Models with keyless access system

* Not available on all models

Diesel models

Vehicle Specifications

Model	AMAZE	
Curb Weight	MT	993 - 1,023 kg
	CVT	1,031 - 1,039 kg
Maximum Permissible Weight	MT	1,450 kg ^{*1}
	CVT	1,460 kg ^{*2}
Weight	CVT	1,470 kg

*1: Models without remote transmitter

*2: Models with remote transmitter

Engine Specifications

Type	Water cooled 4-stroke DOHC i-DTEC diesel engine with turbo charger, intercooler
Bore x Stroke	76.0 x 82.5 mm
Displacement	1,498 cm ³
Compression Ratio	16.0 : 1

Fuel

Fuel: Type	Automotive Diesel Fuel
Fuel Tank Capacity	35 L

Battery

Capacity	36AH(5)/47AH(20)
	38AH(5)/47AH(20)

Washer Fluid

Tank Capacity	1.5 L
---------------	-------

Light Bulbs

Headlights (High/Low Beams)	60/55 W (H4)
Fog Lights *	19 W (H16)
Front Turn Signal Lights	21 W (Amber)
Position Lights	5 W * LED *
Side Turn Signal Lights (on Front Fender) *	5 W (Amber)
Side Turn Signal Lights (on Door Mirrors) *	LED
Brake Lights	21 W
Taillights	5 W
Rear Turn Signal Lights	21 W (Amber)
Back-Up Lights	16 W
High-Mount Brake Light	21 W
Rear Licence Plate Lights	5 W
Interior Lights	
Ceiling Light	8 W
Boot Light	5 W

■ Brake/Clutch* Fluid

Specified	Brake Fluid with DOT 3 or DOT 4	
-----------	---------------------------------	--

■ Continuously Variable Transmission Fluid*

Specified	Honda HCF-2 Transmission Fluid	
Capacity	Change	3.4 L

■ Manual Transmission Fluid*

Specified	Honda Manual Transmission Fluid (MTF)	
Capacity	Change	1.9 L

■ Engine Oil

Recommended	-Honda Diesel Oil #2.0	
	-ACEA C2 or C3 0W-30, 5W-30	
Capacity	Change	4.0 L
	Change including filter	4.4 L

■ Engine Coolant

Specified	Honda All Season Antifreeze/Coolant Type2	
Ratio	50/50 with distilled water	
Capacity* ¹	4.20 L (change including the remaining 0.45 L in the reserve tank)	
	3.96 L (change including the remaining 0.45 L in the reserve tank)	

*1: Continuously variable transmission models

*2: Manual transmission models

■ Tyre

Regular	Size	175/65R14 82T* ¹
	Size	175/65R15 84T* ²
Spare (Full-size tyre)* ¹	Pressure	See the label on driver's doorjamb.
	Size	175/65R14 82T
Temporary Spare* ²	Pressure	Same as the regular tyre. See the label on driver's doorjamb.
	Size	175/70R14 84T
Wheel Size	Pressure	See the label on driver's doorjamb.
	Regular	14 x 5 1/2J* ¹
Spare (Full-size tyre)* ¹	Regular	15 x 5 1/2J* ²
	Spare	14 x 5 1/2J
Temporary Spare* ²	Temporary	14 x 5 1/2J
	Spare* ²	14 x 5 1/2J

*1: Models with 175/65R14 82T

*2: Models with 175/65R15 84T

Indian models only

The tyres fitted in the vehicles meet the requirement of the BIS and they comply with the requirements under the central motor vehicles rules (CMVR), 1989.

■ Brake

Type	Power assisted
Front	Disc
Rear	Drum
Parking	Hand Brake

■ Air Conditioning

Refrigerant Type	HFC-134a (R-134a)
Charge Quantity	315 - 365 g

■ Vehicle Dimensions

Length	3,995 mm	
Width	1,695 mm	
Height	1,498 mm* ¹	
	1,501 mm* ²	
Wheelbase	2,470 mm	
Track	Front	1,490 mm* ³
	Rear	1,487 mm* ³
		1,488 mm* ⁴

*1: Models without fin antenna

*2: Models with fin antenna

*3: Models without keyless access system

*4: Models with keyless access system

* Not available on all models

Identification Numbers

Vehicle Identification Number (VIN), Engine Number and Transmission Number

Your vehicle has a 17-digit vehicle identification number (VIN) used to register your vehicle for warranty purposes, and for licensing and insuring your vehicle. The locations of your vehicle's VIN, engine number and transmission number are shown as follows.

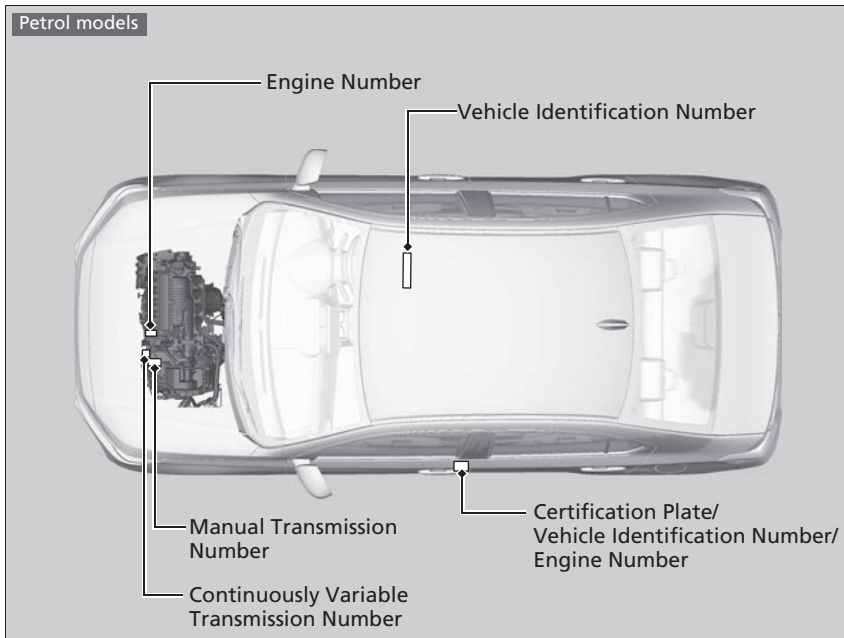

❖ Vehicle Identification Number (VIN), Engine Number and Transmission Number

The interior vehicle identification number (VIN) is located under the floor carpet.

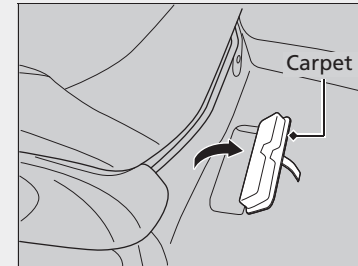

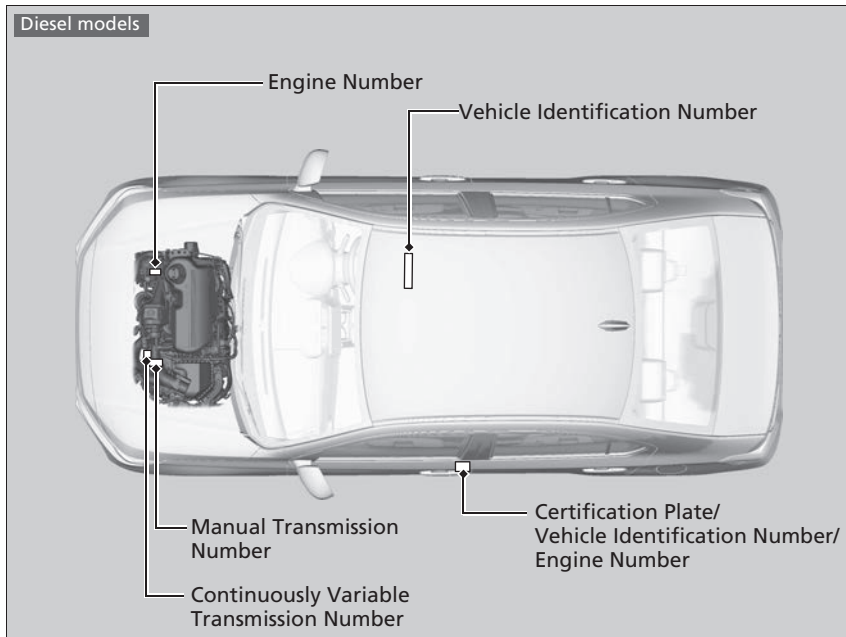

Numbers

7-Speed Manual Shift Mode 210

A

ABS (Anti-lock Brake System) 219

Accessories and Modifications 280

Accessory Power Sockets 136

Adding

Coolant 248

Engine Oil 247

Washer 255

Additives, Engine Oil 243

Adjusting

Clock 90

Front Seats 126

Headlights 119, 256

Mirrors 125

Steering Wheel 124

Temperature 88

Air Conditioning System

(Climate Control System) 143

Changing the Mode 143, 144

Defrosting the Windscreen and

Windows 145

Recirculation/Fresh Air Mode 143, 144

Sensors 146

Using Automatic Climate Control 143

Air Conditioning System

(Heating and Cooling System) 137

Cooling 140

Defrosting the Windscreen and
Windows 142

Heating 138

Air Pressure 268, 315, 317

Airbags 40

After a Collision 42

Airbag Care 46

Event Data Recorders 1

Front Airbags (SRS) 42

Indicator 45, 77

Sensors 40

AM/FM Radio 155

Anti-lock Brake System (ABS) 219

Indicator 77

Armrest 131

Audio Remote Controls 152

Audio System 148

Adjusting the Sound 154

Auxiliary Input Jack 150

Bluetooth® Audio 165

Error Messages 167

General Information 168

iPod 158

MP3 161

Recommended Devices 168

Remote Controls 152

USB Flash Drives 168

USB Port 149

Auto Door Locking/Unlocking 101

Automatic Lighting 117

Auxiliary Input Jack 150

Average Fuel Economy 87

B

Battery 272

Charging System Indicator 74, 300

Jump Starting 294

Maintenance (Checking the Battery) 272

Maintenance (Replacing) 274

Belts (Seat) 30

Beverage Holders 134

Bluetooth® Audio 165

Booster Seats (For Children) 66

Boot 105

Lid 105

Light Bulb 265

Boot Release Button 107

Brake System 217

Anti-lock Brake System (ABS) 219

Fluid 254

Foot Brake 218

Indicator 73, 301

Parking Brake 217

Brake System Indicator (Amber) 73

Brightness Control (Instrument Panel) ... 122

Bulb Replacement 256

Boot Light 265

Brake Light, Taillight, Back-Up Light and Rear

Turn Signal Lights 262

Ceiling Light 265

Fog Lights 257

Front Turn Signal Lights	259
Headlights	256
High-Mount Brake Light.....	264
Interior Lights.....	265
Position Lights.....	260
Rear Licence Plate Lights	263
Side Turn Signal Lights	261
Bulb Specifications	314, 316

C

Carbon Monoxide Gas	68
Carrying Luggage	193, 195
Certification Label	318
Changing Bulbs	256
Charging System Indicator	74, 300
Child Restraint System	47
Booster Seats.....	66
Child Restraint System for Infants.....	50
Child Restraint System for Small Children.....	52
Installing a Child Restraint System with a Lap/ Shoulder Seat Belt.....	61
Larger Children	65
Rearward Facing Child Restraint System	50
Selecting a Child Restraint System.....	53
Using Tether	63
Child Safety	47
Childproof Door Locks	100
Cleaning the Exterior	277
Cleaning the Interior	276

Climate Control System	143
Changing the Mode	143
Defrosting the Windscreen and Windows	145
Recirculation and Fresh Air Mode	144
Sensors.....	146
Using Automatic Climate Control	143
Clock	90
Clutch Fluid	254
Continuously Variable Transmission	
7-Speed Manual Shift Mode	210
Creeping	204
Kickdown	204
Operating the Shift Lever	18, 205, 206, 208, 209
Shift Lever Does Not Move	297
Shifting	205, 208
Continuously Variable Transmission (CVT)	
Fluid	252
Controls	89
Coolant (Engine)	248
Adding to the Radiator	251
Adding to the Reserve Tank.....	248
High Temperature Indicator	77
Overheating	298
Creeping (Continuously Variable Transmission)	204
Cruise Control	214
Indicator.....	81
Cup Holders	134

D

Dead Battery	294
Defrosting the Windscreen and Windows	142, 145
Diesel	19, 225
Fuel Economy and CO ₂ Emissions	228
Information	225
Instant Fuel Economy	86
Low Fuel Indicator	76
Refueling.....	225
Dimming	
Headlights.....	117
Dipstick (Engine Oil)	245
Directional Signals (Turn Signals)	116
Door Mirrors	125
Doors	91
Auto Door Locking.....	101
Auto Door Unlocking	101
Door and Boot Open Indicator.....	29, 77
Keys.....	91
Locking/Unlocking the Doors from the Inside	99
Locking/Unlocking the Doors from the Outside	94
Lockout Prevention System.....	98
Driving	191
Braking	217
Continuously Variable Transmission.....	204
Cruise Control.....	214
Shifting Gear.....	205, 208, 212
Starting the Engine.....	197, 199

E

Electric Power Steering (EPS) System	
Indicator	77, 302
Emergency	310
Engine	318
Coolant	248
Jump Starting	294
Oil	243
Starting	197, 199
Switch Buzzer	111
Engine Coolant	248
Adding to the Radiator	251
Adding to the Reserve Tank	248
High Temperature Indicator	77
Overheating	298
Engine Oil	243
Adding	247
Checking	245
Low Oil Pressure Indicator	73, 300
Recommended Engine Oil	243
Engine Start/Stop Button	112
EPS (Electric Power Steering) System	77
Exhaust Hazard (Carbon Monoxide)	68
Exterior Care (Cleaning)	277
Exterior Mirrors	125

F

Features	147
Flat Tyre	283
Fluids	
Brake/Clutch	254
Continuously Variable Transmission (CVT)	252
Engine Coolant	248
Manual Transmission	253
Windscreen Washer	255
Fog Light Indicator	79
Foot Brake	218
Front Airbags (SRS)	42
Front Seats	126
Adjusting	126
Fuel	224
Fuel Economy and CO ₂ Emissions	228
Gauge	86
Information	224, 225, 314, 316
Instant Fuel Economy	86
Low Fuel Indicator	76
Range	87
Recommendation	224, 225
Refueling	224, 225
Fuel Economy and CO₂ Emissions	228
Fuel Fill Cap	19, 226
Fuel Fill Door	19, 226
Fuses	303
Inspecting and Changing	309
Locations	303, 305, 306, 308

G

Gauges	83
Gear Shift Lever Positions	
Continuously Variable Transmission	205, 208
Manual Transmission	212
Glass (care)	276, 278
Glove Box	133
Glow Plugs Indicator	78

H

Halogen Bulbs	256, 257
Hands-Free Telephone (HFT) System	169
HFT Buttons	169
HFT Menu	171
HFT Status Display	170
Import of Mobile Phonebook	182
Making a Call	186
Menu	171
Options During a Call	190
Phone Setup	175
Receiving a Call	189
Speed Dial	184
To Clear the System	181
HandsFreeLink® (HFL)/Hands-Free Telephone (HFT) System	
Call History	183
Hazard Warning Button	4
Head Restraints	129

Headlights	117
Adjuster.....	119
Aiming.....	256
Dimming.....	117
Operating.....	117
Heating and Cooling System	137
Cooling.....	140
Defrosting the Windscreen and Windows.....	142
Heating.....	138
HFT (Hands-Free Telephone)	169
High-Beam Indicator	79
I	
Identification Numbers	318
Engine and Transmission.....	318
Vehicle Identification.....	318
Ignition Switch	111
Illumination Control	122
Knob.....	122
Immobilizer System	108
Indicator.....	80
Indicators	72
Anti-lock Brake System (ABS).....	77
Brake System (Amber).....	73
Charging System.....	74
Cruise Control.....	81, 215
Cruise Main.....	81, 214, 215
Door and Boot Open.....	77
ECO.....	79

Electric Power Steering (EPS) System.....	77
Fog Light.....	79
Glow Plugs.....	78
High Beam.....	79
High Temperature.....	77
Immobilizer System.....	80
Keyless Access System.....	79
Lights On.....	79
Low Fuel.....	76
Low Oil Pressure.....	73
M (7-speed manual shift mode).....	75
Malfunction Indicator Lamp.....	74
Parking Brake and Brake System (Red).....	73
PGM-FI.....	78
Rotate Wheel.....	81
Seat Belt Reminder.....	76
Shift.....	75
Shift Lever Position.....	75
Shift to Park.....	80
Starter System.....	80
Supplemental Restraint System.....	77
Transmission.....	75
Turn Signal and Hazard Warning.....	79
Water in Fuel.....	78
Instant Fuel Economy	86
Instrument Panel	71
Brightness Control.....	122
Interior Lights	132
Interior Rearview Mirror	125
iPod	158

J	
Jack (Wheel Nut Wrench)	286
Jump Starting	294

K	
Key Number Tag	92
Keyless Access System	94
Indicator.....	79
Keys	91
Lockout Prevention.....	98
Number Tag.....	92
Rear Door Won't Open.....	100
Remote Transmitter.....	94
Types and Functions.....	91
Won't Turn.....	22
Kickdown (Continuously Variable Transmission)	204

L	
Light Switches	117
Lights	117, 256
Bulb Replacement.....	256
Fog Lights.....	118
High-Beam Indicator Light.....	79
Interior.....	132
Lights On Indicator.....	79
Turn Signals.....	116
Load Limits	195

- Locking/Unlocking 91
 - Auto Door Locking/Unlocking 101
 - Childproof Door Locks 100
 - From Inside 99
 - From Outside 94
 - Keys 91
 - Using a Key 97
 - Lockout Prevention System 98
 - Low Battery Charge 300
 - Low Fuel Indicator 76
 - Low Keyless Remote Signal Strength 93
 - Low Oil Pressure Indicator 300
 - Lower Anchorages 58
 - Lubricant Specifications Chart 315, 317
 - Luggage (Load Limit) 195
- ## M
- Maintenance 229
 - Battery 272
 - Brake/Clutch Fluid 254
 - Cleaning 276
 - Coolant 248
 - Oil 245
 - Precautions 230
 - Radiator 251
 - Remote Transmitter 274
 - Replacing Light Bulbs 256
 - Safety 231
 - Transmission Fluid 252
 - Tyres 268
 - Under the Bonnet 240
 - Malfunction Indicator Lamp 74, 301
 - Manual Transmission 212
 - Maximum Permissible Weight 195
 - Meters, Gauges 83
 - Mirrors 125
 - Adjusting 125
 - Door 125
 - Exterior 125
 - Interior Rearview 125
 - Modifications (and Accessories) 280
 - MP3 161
- ## N
- Numbers (Identification) 318
- ## O
- Odometer 86
 - Oil (Engine) 243
 - Adding 247
 - Checking 245
 - Low Oil Pressure Indicator 73, 300
 - Recommended Engine Oil 243
 - Viscosity 243
 - Opening/Closing
 - Bonnet 242
 - Boot 105
 - Power Windows 109
- ## P
- Outside Temperature 88
 - Adjusting 88
 - Overheating 298
 - Paddle Shifters 18, 210
 - Parking Brake 217
 - Parking Brake and Brake System
 - Indicator (Red) 73, 301
 - Passing Indicators 117
 - Petrol 19, 224
 - Fuel Economy and CO₂ Emissions 228
 - Gauge 86
 - Information 224
 - Instant Fuel Economy 86
 - Low Fuel Indicator 76
 - Refueling 224
 - PGM-FI Indicator 78, 302
 - Precautions While Driving 202
 - Rain 202
 - Pregnant Women 37
 - Preset List 157
 - Preset Memory 156
 - Puncture (Tyre) 283

R

Radiator	251
Radio (AM/FM)	155
Range	87
Rear Demister Button	121
Rearview Mirror	125
Reducing CO ₂ Emissions	228
Refueling	224
Diesel	225, 316
Fuel Gauge	86
Low Fuel Indicator	76
Petrol	224, 314
Remote Transmitter	94
Replacement	
Battery	274
Bulbs	256
Fuses	303, 305, 306, 308
Tyres	283
Wiper Blade Rubber	266
Resetting a Trip Meter	86
Rotate Wheel Indicator	81

S

Safe Driving	25
Safety Check	29
Safety Labels	69
Safety Message	0
Seat Belt Reminder Indicator	76

Seat Belts	30
Checking	38
Fastening	34
Installing a Child Restraint System with a Lap/ Shoulder Seat Belt	61
Pregnant Women	37
Reminder	32
Warning Indicator	32, 76
Seats	126
Adjusting	126
Front Seats	126
Security System	108
Immobilizer System Indicator	80
SEL/RESET Knob	84
Select Lever	18, 205, 208, 212
Selecting a Child Restraint System	53
Selector Knob (Audio)	153
Setting the Clock	90
Shift Lever	18, 205, 208, 212
Operation	205, 208, 212
Releasing	297
Shift Lever Position Indicator	209
Won't Move	297
Shift Lever Position Indicator	206
Shift Position Indicator	75
Shifting (Transmission)	205, 208, 212
Spare Tyre	283, 315, 317
Spark Plugs	314
Specifications	314
Specified Fuel	224, 225
Speedometer	83

SRS Airbags (Airbags)	42
Start/Stop Button	112
Starting the Engine	197, 199
Does Not Start	290
Engine Switch Buzzer	111
Jump Starting	294
Steering Wheel	124
Adjusting	124
Stopping	220
Supplemental Restraint System (SRS)	42
Indicator	77
Switches	
(Around the Steering Wheel)	4, 5, 111

T

Tachometer	83
Temperature	
High Temperature Indicator	77
Outside Temperature Display	88
Temperature Sensor	88, 146
Time (Setting)	90
Tools	282
Towing a Trailer	196
Towing Your Vehicle	
Emergency	310
Transmission	205, 208, 212
7-Speed Manual Shift Mode	210
Continuously Variable	205
CVT	208
Fluid	252, 253

Manual.....	212
Number.....	318
Shift Lever Position Indicator	75, 206, 209
Trip Meter	86
Troubleshooting	281
Blown Fuse.....	303, 305, 306, 308
Brake Pedal Vibrates.....	22
Buzzer Sounds When Opening Door.....	23
Diesel Fuel	316
Emergency Towing	310
Engine Won't Start	290
Noise When Braking	23
Overheating.....	298
Puncture/Flat Tyre	283
Rear Door Won't Open	23
Shift Lever Won't Move	297
Warning Indicators	72
Turn signals	116
Indicators (Instrument Panel).....	79
Tyres	268
Air Pressure	315, 317
Checking and Maintaining.....	268
Inspection.....	268
Puncture (Flat Tyre).....	283
Rotation	271
Spare Tyre	283, 315, 317
Wear Indicators	269

U

Unlocking the Doors	94
Unlocking the Front Doors from the Inside	99
USB Adapter	148
USB Flash Drives	168
USB Port	149
Using the Boot Release Button	107
Using the Keyless Access System	94

V

Vanity Mirrors.....	7
Vehicle Identification Numbers.....	318
Ventilation.....	137, 144
Viscosity (Oil)	243, 315, 317

W

Warning and Information Messages.....	82
Warning Indicator On/Blinking	300
Warning Labels.....	69
Water in Fuel Indicator	78
Watts.....	314, 316
Wear Indicators (Tyre).....	269
Wheel Cover	285
Wheel Nut Wrench (Jack Handle)	286
Window Washers Adding/Refilling Fluid	255
Switch.....	120
Windows (Opening and Closing)	109

Windscreen

Cleaning	278
Defrosting/Defogging	145
Washer Fluid.....	255
Wiper Blades.....	266
Wipers and Washers	120
Wipers and Washers	120
Checking and Replacing Wiper Blades.....	266
WMA	161
Worn Tyres	268