



VOLVO S60
& S60 CROSS COUNTRY

INNOVATION FOR PEOPLE

Made by Sweden.

At Volvo Cars, we continuously innovate in order to make your life better. Every car, every technology and every design is the result of a clear vision – to put people at the heart of everything we do. It's a vision that has driven us from the start, one informed by Sweden, a country which values people as individuals and where conventions are challenged. It's a culture with a rich design heritage and a unique way of looking at the world.

This vision has inspired us to create the likes of the three-point safety belt and side-impact airbags – inventions that have saved lives and changed automotive history. And with our new generation of models we continue with this tradition.

Scandinavian design combines with modern Swedish luxury to enrich your experience. Intuitive technology makes life less complicated and keeps you connected with the world, while the latest Drive-E powertrains balance responsive power with class-leading efficiency. And our IntelliSafe innovations support you while you are driving, helping to prevent accidents and protecting you if one occurs. They make every journey safer, more comfortable and enjoyable.

We understand what's important to people. It forms the basis of all the innovations which we create. Innovations that improve lives.

At Volvo Cars, we design our cars around you.

Contents

EXTERIOR DESIGN

INTERIOR DESIGN

SENSUS

INTELLISAFE

DRIVE-E

CHASSIS

YOUR CHOICE

TRIM LEVELS

ACCESSORIES

FACTS AND FIGURES

THE VOLVO EXPERIENCE

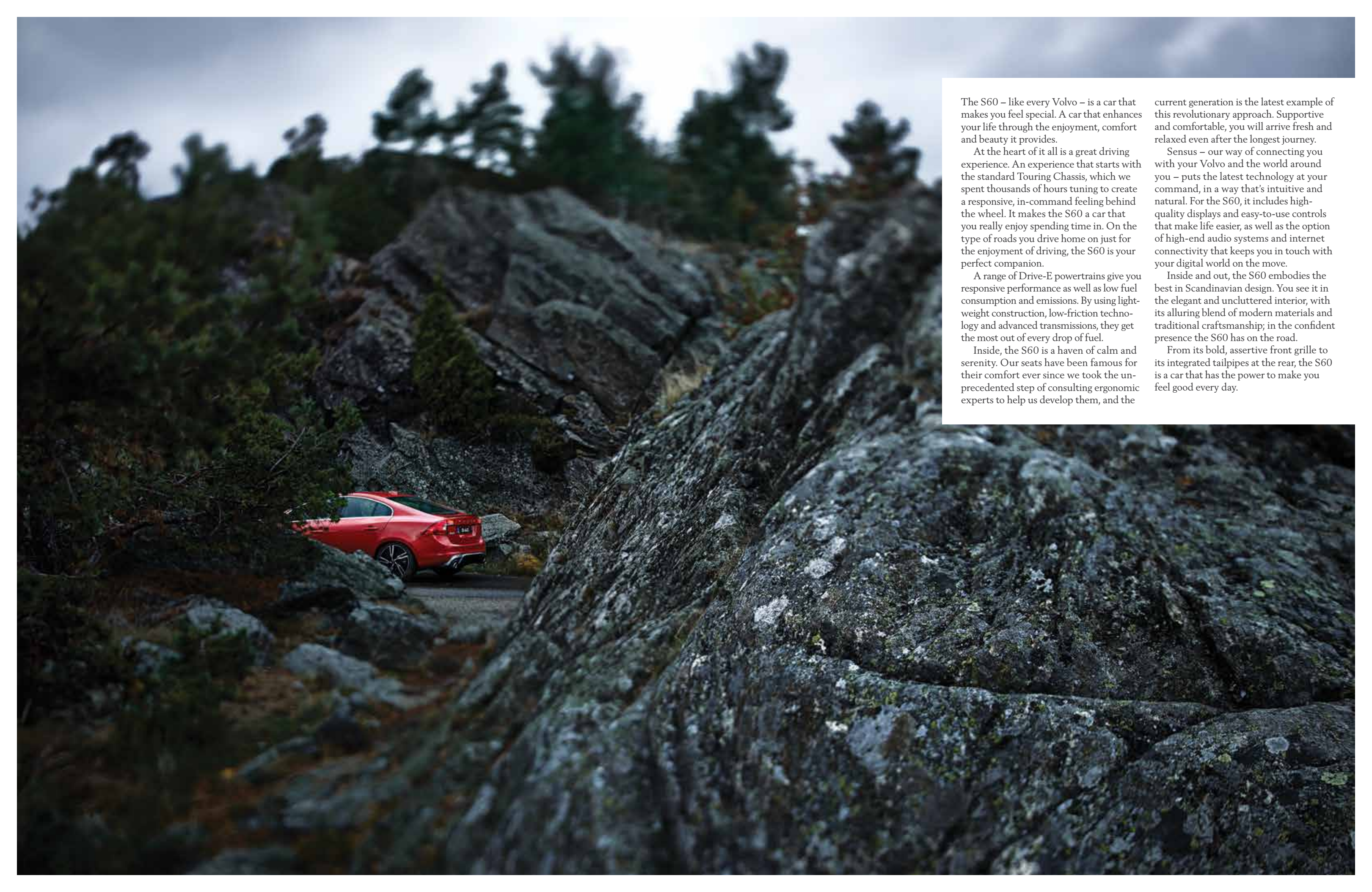

A red Volvo S60 is parked on a narrow, paved road that winds through a rugged, rocky landscape. The car is positioned in the lower-left quadrant of the frame, facing away from the viewer. The surrounding terrain is composed of dark, layered rock formations, with sparse vegetation and several tall, thin evergreen trees in the background. The sky is overcast and grey, creating a moody atmosphere. The overall scene conveys a sense of adventure and connection with nature.

The S60 – like every Volvo – is a car that makes you feel special. A car that enhances your life through the enjoyment, comfort and beauty it provides.

At the heart of it all is a great driving experience. An experience that starts with the standard Touring Chassis, which we spent thousands of hours tuning to create a responsive, in-command feeling behind the wheel. It makes the S60 a car that you really enjoy spending time in. On the type of roads you drive home on just for the enjoyment of driving, the S60 is your perfect companion.

A range of Drive-E powertrains give you responsive performance as well as low fuel consumption and emissions. By using lightweight construction, low-friction technology and advanced transmissions, they get the most out of every drop of fuel.

Inside, the S60 is a haven of calm and serenity. Our seats have been famous for their comfort ever since we took the unprecedented step of consulting ergonomic experts to help us develop them, and the

current generation is the latest example of this revolutionary approach. Supportive and comfortable, you will arrive fresh and relaxed even after the longest journey.

Sensus – our way of connecting you with your Volvo and the world around you – puts the latest technology at your command, in a way that's intuitive and natural. For the S60, it includes high-quality displays and easy-to-use controls that make life easier, as well as the option of high-end audio systems and internet connectivity that keeps you in touch with your digital world on the move.

Inside and out, the S60 embodies the best in Scandinavian design. You see it in the elegant and uncluttered interior, with its alluring blend of modern materials and traditional craftsmanship; in the confident presence the S60 has on the road.

From its bold, assertive front grille to its integrated tailpipes at the rear, the S60 is a car that has the power to make you feel good every day.

"It's designed to make you look for any excuse to get behind the wheel."

VOLVO S60

For people who enjoy taking the long way home.

The Volvo S60 is a beautifully balanced combination of dynamism, style and comfort.

If you are the kind of person who chooses the back roads to get home, you'll enjoy the crisp response of a well-balanced chassis. During longer trips, the relaxed comfort will keep you and your passengers feeling fresh for hours. In more challenging traffic situations – in the city, for example – a range

of supportive technologies will take the stress out of driving and keep you in control.

The agile character of your S60 is enhanced by its looks. The strong shoulders, the distinctive front with advanced headlamps, the sleek roof line and the powerfully sculpted rear section with integrated tailpipes – all make for a strong road presence. Inside, a beautifully crafted interior creates a calm

yet invigorating environment that creates a unique sense of well-being, exactly as befits a Scandinavian design masterpiece.

Add our range of highly efficient Drive-E powertrains and our Sensus technology that connects your Volvo with the world around you – the S60 is truly designed to make you look for any excuse to get behind the wheel.



"The car has a beauty that – as with much of contemporary Scandinavian design – is rooted in the natural world."



SCANDINAVIAN DESIGN:

Yes, it looks as good as it performs.

You know when you're driving on a highway and you look in to your rear-view mirror and see a really striking car's "face" approaching you—that's the Volvo S60.

"The road presence comes from its focused and determined-looking headlights," explains our senior exterior designer Peter Reuterberg. "We were thinking of a wolf's

eyes when we designed the car's 'face'. The S60 has a confident, focused expression, like a powerful animal." The scalloped surfaces on the bonnet accentuate the classic Volvo V-shape with a purposeful frown running right down to the headlamps. The car has a beauty that – as with much of contemporary Scandinavian design – is rooted in the

natural world. "Those clean surfaces and contours give it a very Scandinavian feel," says Reuterberg. The strong shoulders are another unmistakable Volvo design cue – as is the expressive grille with the iconic Volvo diagonal. They enhance the car's self-confident look and tell the world it's proud to be a Volvo.



"We've designed the cockpit around you, the driver."



We've designed the cockpit around you, the driver. Sit in the driver's seat and the dashboard, which is gently angled towards you, puts you in complete command. Inspired by high-performance motorcycles, we came up with the idea of a single round instrument flanked by two smaller dials. Then, we carefully sculpted the three-spoke steering wheel with the aim of giving you a clear sense of connection between your car and the road.

Where you sit is equally important. Volvo takes pride in designing seats that not only offer great comfort, but also outstanding support, so that at the end of every journey you make, you feel as calm and refreshed as when you started. Our sport seats look great

and, true to our commitment to ergonomic design, side supports all the way from your thighs to your shoulders ensure that you stay firmly in position, even when you're cornering fast.

Of course, we're committed to a clean environment inside your car as well. As part of CleanZone, all interior materials in your Volvo are hypo-allergenic and do not emit harmful gases. CleanZone also includes a highly effective dust and pollen filter. You can boost this further with our Interior Air Quality System. This uses an active carbon filter to reduce harmful gases and particles, enabling you and your passengers to breathe easily – even in polluted cities.

No need to take your hands off your steering wheel as you shift up and down the automatic gearbox in manual mode – just flick through the gears with our optional gearshift* paddles. You'll be in total command of your car, with both hands on the wheel. And quicker gear changes for a more responsive drive when you're in the mood.

* For interiors, refer to the specsheet.

"Our vision is that by 2020 nobody should be killed or seriously injured in a new Volvo."

INTELLISAFE

*Intuitive safety by Volvo Cars.
For you, and for those around you.*

At Volvo Cars, safety is an intrinsic part of our DNA. We've invented some of the world's most pioneering life-saving technologies – such as the three-point safety belt that's been acknowledged as one of the most important innovations of mankind.

But we aim higher. Our vision is that by 2020 nobody should be killed or seriously injured in a new Volvo.

IntelliSafe is our approach for a more harmonious relationship between cars and people. To achieve this, we have infused your Volvo with smart, intuitive innovations for a safer drive.

When you drive at speeds up to 50 km/h, our City Safety collision avoidance technology looks ahead of you and brakes automatically if you're about to run into a vehicle in front.

And because we know you love to drive, our active IntelliSafe technologies such as Electronic Stability Control add to reassuring driving stability in all conditions without sacrificing the joy of driving. It's simply about giving you the most human-centric experience, on your terms. And helping to keep people out of harm's way, whether they happen to be inside or outside your car.

Light up the dark. Driving in the dark just became a lot more enjoyable and safer. Our Active High Beam stays on high beam all the time. You don't have to flick between low and high beam, and when you meet or catch up another vehicle, the system shades out only as much of your beam as necessary to avoid dazzling – while you still get the benefit of a brightly lit road. This intelligent technology can even recognise pedestrians and cyclists and avoid dazzling them too. And when you enter a city, the main beam switches off.



INTELLISAFE



City Safety is designed to prevent you from colliding with the car in front if it stops or slows down suddenly. This advanced IntelliSafe system will automatically brake to avoid a collision and works at speeds of up to 50 km/h – an accident can be avoided at a speed difference of up to 15 km/h to the vehicle in front.

"With our new generation 2.0-litre, four-cylinder Drive-E powertrains, you don't need to sacrifice power and superb driveability for efficiency and low CO₂ emissions."



DRIVE-E

*Enjoying more.
Using less.*

Drive-E isn't just about our new generation of efficient powertrains. It's about our all-embracing approach to efficient driving. And while we're committed to creating smarter, more innovative technologies to reduce our cars' impact on the environment, we'll never lose sight of the pleasure to be had in driving. In short, we believe you don't need to sacrifice power and superb driveability for efficiency and low CO₂ emissions.

Our Drive-E powertrain range consists of highly efficient 2.0-litre, four cylinder petrol and diesel engines. We've matched

these turbocharged, low-friction, lightweight powertrains with Geartronic™, our all-new eight-speed automatic gearbox, which ensures you get optimum performance at any engine speed.

Your Volvo also has an ECO+ function which can reduce fuel consumption by up to five per cent, depending on driving style. ECO+ not only optimises shift points, engine control and throttle response. It also includes a Stop/Start system and an ECO coast function. This disengages the clutch when you release the accelerator at speeds above

65km/h: instead of the engine braking the car and using up fuel in the process, your Volvo will coast along using its kinetic energy.

Our Drive-E diesel powertrains have additional technologies designed to reduce fuel consumption and emissions. Twin turbochargers and the revolutionary i-ART ensure that these intelligent engines provide responsive, clean and efficient performance – each cylinder has its own microchip and pressure sensor for perfect metering of fuel. Better still, these advanced engines remain in precise tune even after years of use.

The Volvo S60 is available with a wide range of cutting-edge petrol and diesel engines designed to meet your preferences. All of them are designed to offer maximum driving pleasure while using fuel efficiently and keeping CO₂ emissions at a minimum.

Are you looking for maximum power? Our highly efficient T6 petrol engine with supercharger/turbo technology puts out 306hp at 149g CO₂ emissions for an exhilarating driving experience. Alternatively, our high-performance 190hp D4 diesel powertrains will provide uncompromised efficiency and refinement while just emitting 119g respectively 99g CO₂/km.

DRIVE-E



When you accelerate
out of a corner...
It's like it can read your mind.

We've focused on the natural driving dynamics so that its actions immediately correspond to your desires.

When you accelerate out of a tight corner, for example, your S60 will follow the path

you choose with almost telepathic accuracy. Drivers will love Corner Traction Control, a torque vectoring system that helps you avoid understeer by applying just the right amount of power and brake force to the

inner and the outer wheels as you accelerate out of a corner. You'll find this particularly handy if you're merging into fast moving traffic from a side road.



FREEDOM OF CHOICE, YOUR CHOICE.

In a Volvo, you can enjoy the finer aspects of freedom. Such as the freedom to explore new roads, the freedom to enjoy the experience and – not least – the freedom to create a car that matches your style and personality. Choosing a Volvo is more than a statement of your personality. It's about knowing what's most important in life and going in that direction. To show a greater care for people and the world we share, and never compromise with design and quality. To choose a car that's more human-centric,

more intuitive and more efficient – simply much of what empowers you to live a rich, authentic life.

To ensure you get your new Volvo S60 or S60 Cross Country exactly as you want it, we have created a wide range of options, trim levels and personal expressions. Even if your S60 or S60 Cross Country is already generously equipped as standard and in the Kinetic trim level, you may want to enhance the experience even further with the Momentum trim level.

Or if you're in for a more sportier style inside and out: why not take a look at R-Design? Whatever you prefer, you can rest assured there's a Volvo S60 or S60 Cross Country for you. Read on, and see what your new S60 will look like. And if you already know it is the S60 Cross Country that best befits your adventurous lifestyle, then kindly refer to the specification sheet for further information.



Volvo S60 Kinetic



Volvo S60 Momentum



Volvo S60 R-Design



Volvo S60 Cross Country Inscription

RDESIGN

INSPIRED BY THE ART OF DRIVING

If you love to drive, the S60 R-Design is for you. With a unique personality, R-Design captures the thrill of a spirited driving experience characterised by style, responsiveness and control. A wealth of distinguished design details raises the dynamic soul of your Volvo sports sedan and gives it an even sportier, distinct road presence. It's an expression

that catches the eye from every angle and hints at the promise of an amazing drive, every time. And you can rest assured that the S60 R-Design will deliver. Surrounded by meticulously crafted and expressive interior design details, you can feel it right from the moment you take your position in the sculpted R-Design sport seat. Everything – from

the R-Design steering wheel and digital driver display, to the Charcoal headlining – is there to inspire and support your driving. And for even better cornering, the S60 R-Design benefits from a fine-tuned Sport chassis.



RDESIGN

R-Design is Volvo in smart designer sports gear. It's all about a performance-inspired look and feel, both inside and out. It's a truly eye-catching expression with sporty exterior design cues, such as its own distinctive grille in Matt Tech Black with high-gloss stripes, front spoiler, Bright Silver Matt finish door mirror caps and striking 18-inch alloy wheels. At the back, prominent chrome dual tailpipes and a motorsport style rear diffuser with aero fins add the perfect finishing touch.

On the inside, the sporty theme continues with unique R-Design decor inlays, Charcoal headlining and R-Design sport seats in

leather/perforated leather. Together, these features give the cabin a technical, cockpit-like feel. Contrasting stitching in the seats, the gear shifter gaiter and the steering wheel in perforated leather, all reinforce the sporty yet elegant ambience. The deeply sculpted R-Design sport seats will embrace you from your thighs to your shoulders for the comfortable support and in-command feel you expect from a true driver's car. Further adding to your sense of being in control, the R-Design also provides you with a digital driver display with a unique R-Design display mode.

Behind the wheel, you can enjoy the sharp response and feedback from quicker steering and a finely tuned R-Design sport chassis. Lower and firmer, this chassis features adjusted anti-roll bars and stiffer springs. The unique rear monotube dampers are designed to respond more quickly for improved body control in all conditions. Stiffer bushings together with a front strut brace that stiffen up the body structure give more controlled roll and body movements, resulting in a sporty road-hugging drive without you having to compromise ride comfort.



1. The sculpted R-Design sport seats with unique perforated leather upholstery and contrasting stitching for a dynamic touch. **2.** The R-Design interior featuring R-Design leather steering wheel, digital driver display in R-Design mode, leather gear shifter gaiter, R-Design decor inlays and sport aluminium pedals. **3.** The R-Design Matt Tech Black front grille and spoiler with LED daytime lights and the door mirror caps in Silk Matt Silver look add to the dynamic character. **4.** The R-Design rear diffuser with integrated dual tailpipes for a distinctive road presence. **5.** The stylish R-Design tread plates in Silk Metal finish greet you onboard.

DRIVING DYNAMICS WITH A SPIRIT FOR ADVENTURE

We designed the Volvo S60 Cross Country for adventurous individualists who want to stand out and need a capable car with a rugged yet refined design that fits in with an active lifestyle. Thanks to its raised ground clearance and capable chassis, the S60 Cross Country delivers what its appearance promises: it has real all-road, all-weather capability which can be further enhanced with all-wheel drive.

The minute you set eyes on the Volvo S60 Cross Country, you know it means business.

At the same time, rugged design cues add to the car's muscular stance and leave you in no doubt that this car is ready for any adventure.

And above all, this Cross Country sports sedan is a dynamic driver's car. Behind the wheel you'll enjoy an engaged driving experience, no matter how remote your destination is.

Equally at home on all roads – from rough gravel roads to highways – this really is a Volvo for people who don't just talk about adventure, but live it too. For them, all-weather

capability and the ability to occasionally leave smooth, well-travelled roads behind are essential. For that, you need a tough, durable and well-equipped partner that doesn't compromise on capability and luxury. And that's really what the S60 Cross Country is all about.



The Volvo S60 Cross Country offers sleek, stand-out style with all-wheel drive ability and a 201mm of ground clearance. It possesses a unique combination of coupe-like style and tough capability to take adventurous drivers further, whatever the weather and wherever the destination.

With rugged design elements all around, this car challenges you to braving the elements and exploring new terrain. In the front, a black honeycomb grille and lower grille decor elements in black give it our unique Cross Country "face", which is further enhanced by a front skid plate. Black wheel-arch extensions make for a wide, muscular stance and continue seamlessly into the distinctive side scuff plates. A rear skid plate protects your car from gravel when you

leave the tarmac and adds to the powerful impression together with the integrated chrome tailpipes. Glossy black detailing on the mirrors and window frames give the S60 Cross Country a touch of exclusivity.

However, this ability on rough roads and forest tracks doesn't come at the expense of an engaging, sporting drive on smooth tarmac: with Corner Traction Control, the Volvo S60 Cross Country gives you pure driving pleasure on winding country roads.

Choosing all-wheel drive you'll enhance your capability to drive on in difficult conditions, while Hill Descent Control allows you a smooth and confident descent on steeper terrain.

Inside, you and your passengers can relax in a refined, meticulously crafted cabin with a host of thoughtful features. Sculpted sports

seats keep you firmly in place through the corners. And choosing the S60 Cross Country Inscription, you can enjoy the comfort of power operated leather seats. A digital driver display with three graphic modes will add to your feeling of being in command, just as the rain sensor that automatically activates the wipers when needed. During long trips, your rear seat passengers will appreciate the rear armrest with cup holders and storage.

So if you're looking for a car that not only stands out from the crowd, but is also a perfect companion on all roads, the Volvo S60 Cross Country is for you.

The S60 Cross Country is available with D4 AWD.



1. The integrated chrome tailpipes and rear skid plate lends the tail a rugged yet dynamic look. **2.** Leather sport seats with contrasting stitching for your refined experience. **3.** A distinct front with black honeycomb grille, lower front side mouldings and front skid plate. The side scuff plates harmonise perfectly with the front and rear skid plates and emphasise the high ground clearance.

"Our Park Assist Camera, front blind view allows you to 'see around corners' as you negotiate tight exits."

NO TWO LIVES ARE THE SAME

Make sure your Volvo matches yours.

A pleasurable part of buying a new Volvo is putting your personal stamp on it. You can do this by choosing accessories that reflect your own taste and that cater to your particular lifestyle.

To take the stress out of driving, we have developed technology such as our Park Assist Camera, front blind view. It allows you to see around corners with a 180° field of vision as you negotiate tight exits with restricted visibility. The image is projected onto your 7-inch centre display so you know exactly who, or what, is approaching.

Our Park Assist Camera, rear does the same job when you reverse. It's mounted in

the boot lid and dramatically increases your field of vision behind the car. The image is projected onto your centre display, so you can spot any low obstructions when manoeuvring. There's also a zoom-in view you can use to hitch up a trailer to your towbar.

For your children, our new generation Volvo child seats help provide world-class protection and premium comfort. Infants of up to one year-old (or 13kg) travel safely backwards in our new comfortable rear-facing infant seat. And because we recommend that children should travel facing the rear for as long as possible, our new rear-facing child seat for children up to 6 years (or 9–25kg) allows the

child to be seated backwards for many years with generous legroom. When the child has outgrown the rear-facing child seat, our new booster seat with backrest is designed to position the child at the correct height for the safety belt. The child seats' elegant soft wool upholstery matches the interior of your Volvo and provides excellent breathable and moisture-absorbing characteristics for maximum comfort.



To reinforce the dynamic stance of your S60, you can customise it with our Exterior Styling Accessories, which are available in Matt Silver or Matt Iron Stone.

Our eye-catching front skid plate gives your S60 an even more purposeful look, with a metallic colour that's beautifully accentuated as it catches the light. The side scuff plates emphasise the sleek, coupé-like lines, visually connecting it close to the road. The rear skid plates with beautifully sculpted double integrated tailpipes boldly underline the sporty character.



“Our Rear Seat Entertainment system with 8-inch touch screens and integrated DVD players can operate independently.”



Artio, 8x19"
Matt Tech Black/Diamond Cut



Modin, 8x18"
Black/Diamond Cut or
Matt Iron Stone/Diamond Cut



Freja, 8x18"
Light Grey/Diamond Cut or
Matt Dark Grey/Diamond Cut



Since there can only be one driver at a time, the S60 also offers some premium amusement for your rear seat passengers. Our rear seat entertainment system with 8-inch touch screens and integrated DVD players can operate independently. Wireless headphones are standard (you can also plug in your own wired headphones), so

one passenger's game doesn't clash with another passenger's movie.

And adding our illuminated instep plates, you'll enjoy a sophisticated welcome every time you open the front door and enter your S60 – the Volvo logo embedded in the brushed stainless steel footstep lights up together with the interior lighting.



1. The Complete Performance Package includes essential hardware to add performance while subtle exterior details – such as the black door mirror caps and black lower door decor stripes – underline the dynamic appearance of your S60.

2. The Polestar boot lid spoiler will efficiently aid high-speed stability as well as sharpen the car's appearance. 3. The lightweight Polestar 19-inch alloy wheels with high-performance tyres will help with added steering precision and road grip. 4. Designed to reduce back-pressure, the stainless steel exhaust system with larger tailpipes gives the engine note a harder edge while also allowing it to breathe more freely for improved performance. A rear diffuser enhances downforce to increase stability at high speeds. 5. The engraved Polestar instep plate in stainless steel reminds you what you're about to drive every time you open the door. 6. Sport pedals in aluminium with rubber inserts. 7. The Polestar gear knob is available for both manual and Geartronic™ transmissions.

Polestar Performance Parts. Made to Perform.

It is our passion for driving that led us to design this range of Polestar Performance Parts for your Volvo S60. Developed by the same team responsible for our motorsport success and our dynamic road car Volvo S60 Polestar, the new Polestar Performance Parts programme fulfils Volvo Polestar's engineering philosophy by delivering a balanced, energetic driving experience.

The Polestar Performance Parts are designed for the most critical performance areas of your S60 and are available as a Complete

Performance Package. This includes everything from improvements to the chassis, wheels and tyres, intake and exhaust as well as aerodynamics and interior details. Any of these components will create a more compelling drive, and are also available in separate packages. With the Chassis Package, you'll get Polestar-developed shock absorbers and coil springs, as well as a strut bar, for a more direct and responsive driving experience. The Wheel Package includes the lightweight 19-inch Polestar wheel and high-performance tyres for maximum grip. Then there's the Intake &

Exhaust Package, designed for our new generation Drive-E powertrains. It combines a sports air filter with a Polestar air box lid and a stainless steel exhaust system. This package will deliver the most dynamic engine characteristics when combined with Polestar Performance Optimisation.

All Polestar Performance Parts meet all Volvo safety requirements. They are developed and tested by Volvo Cars and Polestar, ensuring a perfect fit and finish, as well as impeccable road manners, and with no impact on the car's limited factory warranty.



The simplest way to own a car.

We love it when you're happy. When things are easier than you expect, or go faster and become better. Because when you buy a Volvo, you buy the simplest way to have a car. Financing, insurance, servicing, changing tyres, cleaning – those aspects of car ownership that you might not find very interesting, are the ones that we love to make easier and better for you. That's why your

Volvo Car dealer will always offer you a whole range of simplifying services and offers all designed around you, giving you the most carefree ownership experience possible.

Still, this is just the beginning. Through our uniquely Swedish approach to innovation, we continuously find new ways to make your life simpler. For instance, the Connected Service Booking function, which lets you book an

appointment just by pushing a button in your car. Or the new way of working in teams – like in a racing pit-stop – that is gradually being introduced in Volvo Car workshops all over the world. We call it Volvo Personal Service and it will make your workshop visits much shorter and more convenient. In the future, servicing your car will be so much simpler.

BUYING & OWNING

- Extended Warranties
- Financing
- Insurance
- Service Contract

MAINTENANCE & SERVICES

- Volvo Genuine Service
- Volvo Professional Car Care
- Tyre services

IF SOMETHING HAPPENS

- Volvo Assistance
- Repairs
- Volvo Glass Services
- Volvo Dent Repair
- Car Climate Services



S60 CROSS COUNTRY SPECIFICATION SHEET

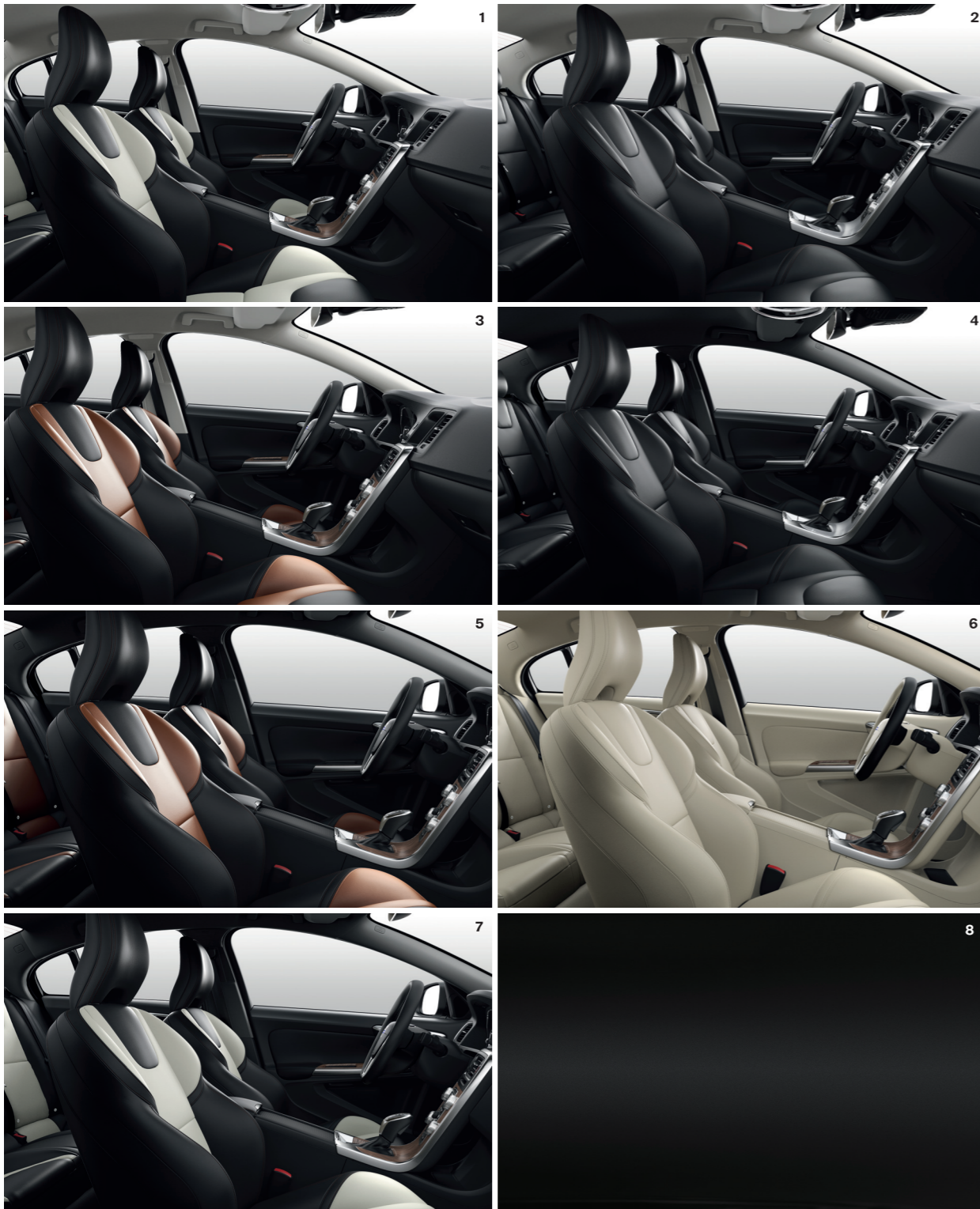

UPHOLSTERIES: Leather Sport **1.** Offblack/Blond in Anthracite Black interior with Quartz headlining (330G) **2.** Offblack in Anthracite Black interior (330L) **3.** Offblack/Beechwood Brown in Anthracite Black interior with Quartz headlining (330N) **4.** Offblack in Anthracite Black interior with Charcoal headlining (336L) **5.** Offblack/Beechwood Brown in Anthracite Black interior with Charcoal headlining (336N) **6.** Sport Leather Soft Beige in Sandstone Beige interior with Soft Beige headlining (331T) **7.** Sport Leather Offblack/Blond in Anthracite Black interior (336G)

INLAYS **8.** Piano Black Wood

TECHNICAL DATA	S60 Cross Country Inscription
Capacity (ccm)	2400
Max Output (hp)	190
Max Torque (Nm)	440
Ground Clearance (mm)	201
Fuel Type	Diesel
CLIMATE	
CleanZone (Air Quality System)	S
Electronic Climate Control	S
IR reflective windscreen	S
Electrically heated rear window	S
Sunroof	S
Sun curtain, rear windscreen	S
LOCKING AND SECURITY SYSTEMS	
Basic Alarm with Interior movement sensor (IMS)	S
Key integrated remote control, central locking	S
Personal Car Communicator with Keyless Drive	S
Home safe lighting	S
Power child lock, rear doors	S
Private locking, trunk	S
Inner lock button & diode, all doors	S
Global open/close doors+sunroof	S
Auto up/down power windows, all doors	S
Laminated windows all around	S
Water Repellent Front Side Windows	S
INSTRUMENTATION	
Digital combi instrument	S
SEATS	
Sport leather seats	S
Power adjustable driver seat with memory	S
Power adjustable passenger seat	S
Heated seats	S
El folding rear headrests	S
INTERIOR	
Decor "Piano Black Wood"	S
Audio controls in steering wheel	S
Leather steering wheel, with Decor inlays, 3 spoke	S
Gear Shift Paddles	S
Leather gearknob	S
Automatic dimmed inner mirror + Compass	S
Illuminated vanity mirror, driver (passenger is std)	S
Interior lighting high version without gear shift illumination	S
Ashtray, front/rear and front cigarette lighter	S
Rear armrest with cupholders and storage	S
Sun curtain, rear windscreen	S
Textile floor mats (4 pieces)	S
Sun glass holder	S
Front cup holders in tunnel console	S
Storage in front doors & centre console	S
Front armrest	S
Parking Ticket holder	S
LUGGAGE COMPARTMENT	
Temporary sparewheel T125/80R17	S
Jack	S

VOLVO S60 CROSS COUNTRY

Exterior Colours, Trim Level, Upholsteries and Alloy Wheels

EXTERIOR		S60 Cross Country Inscription
Glossy Black decor side windows		S
Black Glossy foot, Rear View mirror outer		S
Heated and electrically adjustable outer mirrors		S
Retractable rear view mirrors		S
Active bending lights		S
Headlight washer, low flow		S
LED Daytime Running Lights (DRL)		S
Dual exhaust tail pipes, integrated		S
Rear spoiler		S
Skidplate Coated		S
SUPPORT SYSTEMS		
Trip computer		S
Cruise control		S
City Safety		S
Blind Spot Information System		S
Park Assist Camera		S
Park Assist, front and rear		S
Hill Descent Control		S
Hill Start Assist		S
Height/length adjustable steering wheel		S
Speed sensitive power steering		S
Rain sensor		S
Tyre pressure monitoring system		S
SAFETY		
2 step airbag, drivers/passenger side		S
Passenger airbag		S
SIPS airbags & Inflatable curtains		S
Whiplash protection, front seats		S
Seat belt reminder, front seats		S
Pyrotechnical pretensioners, front/rear all positions		S
Cut-Off Switch Passenger AirBag		S
Isofix - outer position rear seat		S
Emergency Brake Assist, EBA		S
Emergency Brake Light, flashing		S
High positioned rear brake lights		S
Intelligent Driver Information System		S
AUDIO, NAVIGATION & TELEMATICS		
Premium Sound System		S
Single DVD player with Mp3 Decoder		S
AUX / USB / Bluetooth handsfree and Audiostreaming		S
Audio controls in steering wheel		S
Navigation		S
Remote control		S
TRANSMISSION/ENGINE		
Automatic 6-speed AWD		S
Auto Stop/Start		S
ENGINE INSTALLATION		
Speed limit 210 km/h		S
CHASSIS		
Chassis, Dynamic		S
Electronic Stability Control, ESC		S
Electrical parking brake		S
Antilock Brake System, ABS		S
WHEELS		
NESO Diamond Cut alloy wheels 45.72 cm (18 inch)		S



707
Crystal White Pearl



711
Bright Silver Metallic



712
Rich Java



714
Osmium Grey



717
Onyx Black



Neso, 45,72cm (18 inch)
Matt Tech Black/Diamond Cut

VOLVO S60

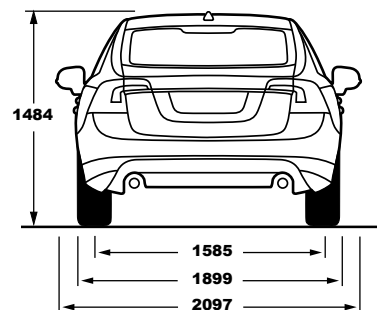
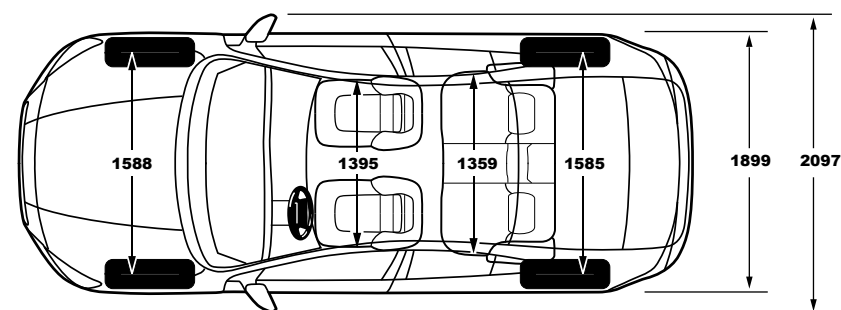
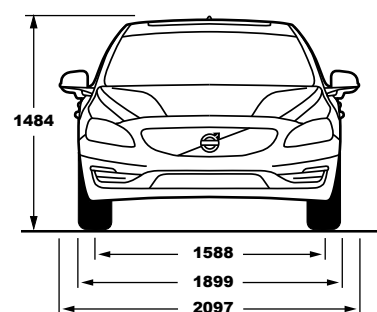
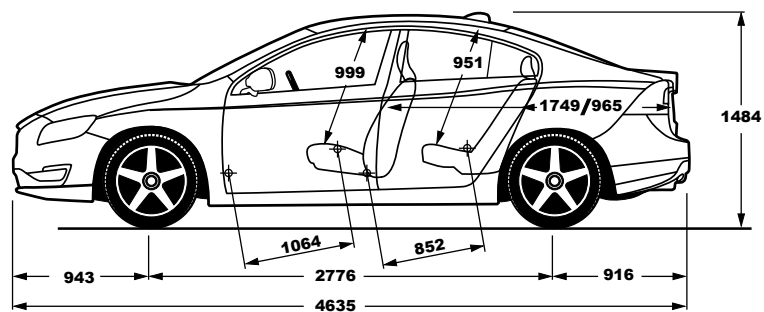

VOLVO S60 CROSS COUNTRY

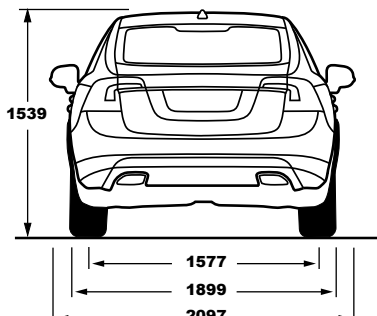
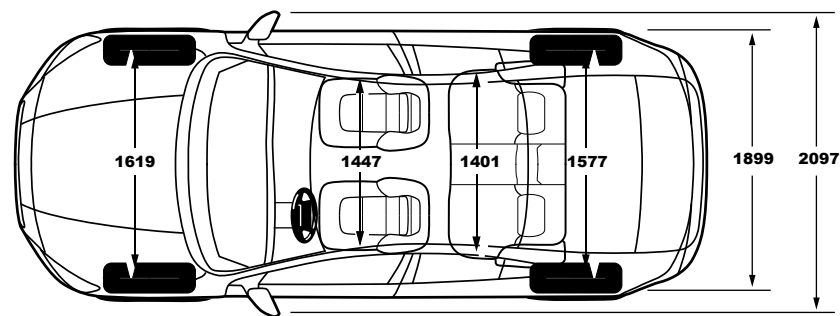
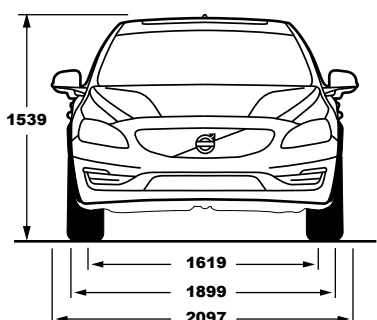
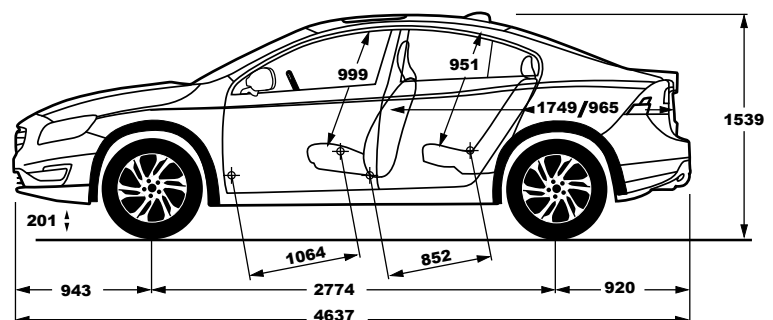

Please note: Some of the information in this brochure may be incorrect due to changes in product specifications that may have occurred since printing. Some of the equipment described or shown may now only be available at extra cost or may no longer be offered. Before ordering, please ask your Volvo Car dealer for the latest information. The manufacturer reserves the right to make changes at any time and without notice to prices, colours, materials, specifications and models.

V O L V O