

 **CITROËN**



THE NEW CITROËN C3

— #EXPRESSYOURSTYLE —



THE MAN BEHIND A **CENTURY-OLD LEGACY**



The brand Citroën owes its remarkable success to an audacious, maverick Frenchman - André Citroën. Driven by a dream to make cars more accessible to everyone, he founded Citroën in 1919. With his ground-breaking vision, the company would go on to revolutionise car manufacturing in Europe and become a pioneer in automotive innovation.

André Citroën developed the double-helical gears with V-shaped teeth years before he founded the company he named after himself.

The gears proved to be a game-changer, bringing him immense success. Little wonder then, the gears held great significance for him – so much so that he based the design of Citroën's logo on the very same gears. Besides his entrepreneurial gifts, he was renowned for his advertising acumen, dazzling audiences with bold and never-seen-before campaigns. André Citroën's spirit has endured at Citroën for over a century, inspiring the company's designers and engineers to be as audacious as he was. And to push the boundaries of what is possible.



#EXPRESSYOURSTYLE

Every individual has a unique personality. Reflected by an expression that showcases your true self - comfortably. An expression that leaves a mark. And an expression that becomes your distinctive style.

So, now its time that you have a car that feels like an extension of you. The New Citroën C3, a truly "Customised Unique Vehicle" allows you to do just that. By giving you the "comfort of customisation" and styling your car the way you want it with **10 exterior colour combinations** and **3 packs with 56 customisation options**.

KEY STRENGTHS



SUV STANCE

Enjoy its SUV stance with high ground clearance and a confident & high driving position.

CUSTOMISED COMFORT

#ExpressYourStyle with the New C3 that truly represents who you are through an range of 10 exterior colour combinations and 3 packs with 56 customization options.

DESIGN

Fuelled by the signature Citroën design DNA, tracing the lines that etch a strong attitude, the New C3 stands tall with an SUV stance, sporting a high bonnet and dual-LED DRLs.

TROPICALISED AC

Discover a new way of driving in comfort with a tropicalised air-conditioning system that delivers faster & efficient cabin cooling specially customised for the Indian summer.

INFO10MENT

Settle into a comfortable drive with an infotainment system that literally reflects your life.

HAPPY SPACE

With generous spaces to stretch your legs, enough headroom & tropicalised air-conditioning enjoy every drive in comfort with room for everybody and everything.

LATEST GENERATION ENGINES

The New C3 is fun to drive thanks to its latest generation engines mated to super smooth transmissions that help you express your style, with power to make your drive more enjoyable to experience a perfect balance of efficiency and driving pleasure.

INTERIOR AMBIENCE

Cocoon yourself in comfort and style that is so chic & yet so reassuring, designed for comfort at your fingertips.

EXTERIOR DESIGN



New C3 brings alive a unique design to your urban expression. Innovative design & styling runs through our DNA, which is perfectly illustrated in the dual chrome chevrons with chrome extensions in the front grill. It beckons you to slip behind the wheel of the New C3, a hatchback with a twist.

The SUV attitude comes alive with its strong wheel arches, fluid lines, and unique proportions that feed into this subtle yet confident stance.



INTERIOR AMBIENCE

Step into a stylish cocoon of comfort that complements the bold SUV design cues of the exterior. The bespoke dashboard lends width to the front view and comfortable yet tall front seats with contrast stitching and a 26cm Citroën Connect Touchscreen provide a welcoming environment to reflect your style. The New C3 offers two interior ambiances with unique seat trims and colour touches that uplift your mood in a space that you'll enjoy on every drive.

*The Citroën*ist
Est. 1919



The Citroën Advanced Comfort™ Program delivers innovative, technological & intelligent solutions for drivers & passengers alike and provides an enhanced sense of comfort that goes beyond mere functionality. This comfort engineering is brought alive by the four main themes of the New C3:

LIVE ELEVATED

INFO10MENT

CUSTOMISED COMFORT

HAPPY SPACE



LIVE

ELEVATED

The New C3 is a hatch with a twist that's inspired by SUV styling codes that attracts attention wherever you go. The car is designed with a high ground clearance of 180 mm along with a higher driving position that is 100 mm more than some of the other sub 4m hatchbacks. For enhanced driving comfort, the driver seat is height-adjustable along with tilt adjustable steering wheel. The suspension system is tuned for varied driving conditions offering refined chassis-suspension dynamics for a flying carpet effect.

The New C3 features an imposing SUV stance which is accentuated by its high bonnet, split headlights, extended chrome chevrons, wheel arches with cladding, front skid plate and the fluid lean muscle exterior design form that give it a stylish & differentiated road presence.



CUSTOMISED **COMFORT**

Every individual desires to express his or her style. The New C3 enables you to do that through a vast array of customisation choices.

Citroën adds a bit of fun in the selection process with ready-made colour & chrome packs that match the exterior highlights to dual-tone or single-tone roof options and two dashboard colors to customise your own distinct style with 10 exterior colour combinations and 3 packs with 56 customisation options. It's time to let yourself be comfortable and #ExpressYourStyle.

- 4** | EXTERIOR COLOURS
- 2** | ROOF COLOURS
- 2** | DASHBOARD COLOURS
- 3** | PACKS WITH **56** CUSTOMISATION OPTIONS



INFO10MENT



Enjoy your drive with an infotainment system that literally reflects your life. Use the intuitive and modern 26cm Citroën Connect touchscreen that utilises Mirror Screen technology to duplicate the functions of your smartphone.

With wireless compatibility with Apple CarPlay™ and Android Auto, you can access your multimedia content and apps, or simply manage your smartphone directly through the large high definition touchscreen. Relax in the comfort of The New C3 and enjoy a seamless driving experience.

*Application features and displays may vary depending on the different operating systems or smartphone devices being used. Avoid using the phone while driving for your safety.





HAPPY SPACE

The New C3 provides a welcoming interior ambience that is stylish, spacious & comfortable. There's room for you and your loved ones with storage space for an errand in the city a journey outside. With an impressive 1378mm rear shoulder room, now don't worry about seating your family or friends in the backseat.

Comfort also take a front seat with 991mm head room. With 2540mm wheel-base of New C3, enjoy a stable and comfortable ride with more space for everyone. With functional & smart storage spaces throughout the cabin, you'll always find room to tuck away your daily essentials and a lot more.



BOOT SPACE

Wherever you are heading to or who you are going with, the spacious 315l boot space of the New C3 can cater to all your luggage needs.



ENGINE

SPECIFICATION

The New C3 is built to perform enthusiastically and efficiently for the unmistakable Citroën experience. It gives you the opportunity to truly express yourself with the 1.2l PURETECH 110 and the 1.2l PURETECH 82.

PURETECH 82

- 1.2l - 5 Speed Manual Transmission
- 3 Cylinders - 82 ps output
- Fuel efficiency of 19.8 km/l*

PURETECH 110

- 1.2l - 6 Speed Manual Transmission
- 3 Cylinders - 110 ps output
- Fuel efficiency of 19.4 km/l*

T&C: *As certified by test agency under Central Motor Vehicle Rules, 1989.

COLOUR COMBINATIONS

4 MONOTONE BODY COLOURS



POLAR WHITE



ZESTY ORANGE



PLATINIUM GREY



STEEL GREY

6 DUAL TONE OPTIONS



POLAR WHITE BODY WITH ZESTY ORANGE ROOF



PLATINIUM GREY BODY WITH ZESTY ORANGE ROOF



POLAR WHITE BODY WITH PLATINIUM GREY ROOF



STEEL GREY BODY WITH ZESTY ORANGE ROOF



ZESTY ORANGE BODY WITH PLATINIUM GREY ROOF



STEEL GREY BODY WITH PLATINIUM GREY ROOF

3 CUSTOMISATION PACKS



ZESTY ORANGE



PLATINIUM GREY



CHROME

2 INTERIOR TRIMS



ANODIZED ORANGE



ANODIZED GREY



CITROËN
**BUY
ONLINE**
COMFORT AT YOUR FINGERTIPS

- Anytime anywhere access
- Virtual 3D configurator
- Test drive access
- Dedicated e-sales advisor
- E-trade-in with online quote
- E-access to finance & Insurance
- E-buy extended warranty & service packages
- Home Delivered-Direct from Citroën



WARRANTY

At Citroën, comfort and mobility are at the heart of everything we do. Citroën Warranty Programme has been designed with these values as well. With services like standard vehicle warranty for 2 years or 40,000 km (whichever is earlier) and 24/7 Roadside Assistance (Toll-free number – 1800 419 2000), we promise to make your Citroën experience truly comfortable. Extended warranty and maintenance packages are also available through your dealer. Additionally, you can access a network of dealerships equipped with state-of-the-art service facilities, tools, and equipment. Service appointments may be booked in advance on www.citroen.in or call the Citroën Customer Experience Centre at 1800 267 1000. WhatsApp +91 73585 02839.

TECHNICAL SPECIFICATIONS

ENGINE	PURETECH 82	PURETECH 110
Fuel Type	Petrol	
No. Of Cylinders	3	3
Displacement (cc)	1198	1199
Max. Engine Output (ps (kw) @ rpm)	82 ps (60 kw) @ 5750 rpm	110 ps (81 kw) @ 5500 rpm
Max. Torque (Nm @ rpm)	115 Nm @ 3750 rpm	190 Nm @ 1750 rpm
Fuel Efficiency (km/l)	19.8	19.4
Transmission	5-MT	6-MT
Fuel Tank Capacity (l)	30	
DIMENSIONS		
Overall Length (mm)	3981	
Overall Width (w/o mirrors) (mm)	1733	
Overall Height (Unladen) (mm)	1586/1604 (With Roof Rails)	
Wheel Base (mm)	2540	
Boot Space (l)	315	
WEIGHTS		
Kerb Weight (kg)	LIVE : 939, FEEL : 964	1035
Gross Vehicle Weight (kg)	1364	1435
SUSPENSION		
Front	MacPherson Strut with Coil Spring	
Rear	Rear Twist Beam with Coil Spring	
BRAKES		
Front	Disc	
Rear	Drum	
STEERING		
Power Steering Type	Electric	
Minimum Turning Circle Radius (m)	4.98	
TYRE SIZE		
Tyres	195/65 R15	
Spare Wheel	165/80 R14 Steel	185/65 R15 Steel

DIMENSIONS

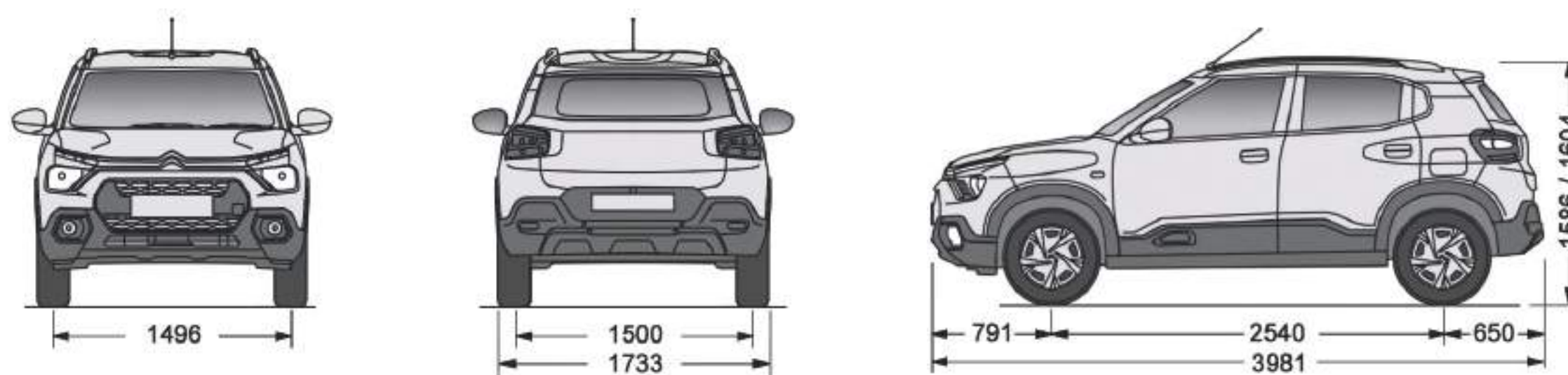

All measurements are in millimetres.

Terms and Conditions: Accessories shown may not be part of standard equipment. The colours shown may vary from the actual colour. Features and specifications may change without prior notice. Dimensions and proportions may not be exact due to digital layout.

FEATURES

VARIANTS	LIVE	FEEL
PureTech 82	✓	✓
PureTech 110		✓
EXTERIOR		
Front Panel: Brand Emblems - Chevron	Silver Painted	Chrome
Front Grill - Matte Black	•	•
Body Coloured Front & Rear Bumpers	•	•
Halogen Headlamps	•	•
Side Turn Indicators on Fender	•	•
Body Side Sill Panel	•	•
'TESSERA' Full Wheel Cover	•	•
Sash Tape - A/B Pillar	•	•
Sash Tape - C Pillar		With Dual Tone Only
Body Coloured Outside Door Handles		•
Outside Door Mirrors	Glossy Black	High Gloss Black
Wheel Arch Cladding		•
Skid Plate - Front		•
Signature LED Day Time Running Lights		•
Roof Rails - Glossy Black		•
Dual Tone Roof		"Puretech 82 - Option Puretech 110 - Standard"
INTERIOR		
Interior Environment - Single Tone Black	•	•
Seat Upholstry - Fabric (Bolster/Insert)	Rubic/Nimbus	Rubic/Hexalight
Front & Rear Seat Integrated Headrest	•	•
AC Knobs - Satin Chrome Accents	•	•
Parking brake Lever Tip - Satin Chrome	•	•
**Instrument Panel - Deco (Anodized Grey / Anodized Orange)		•
AC Vents (Side) - Glossy Black Outer Ring		•
Insider Door Handles - Satin Chrome		•
Satin Chrome Accents - IP, AC Vents Inner Part, Gear lever surround, Steering wheel		•
INFOTAINMENT AND CONNECTIVITY		
Citroën Connect Touchscreen (26cm)		•
Bluetooth® Connectivity		•
Mirror Screen (Apple Carplay™ And Android Auto) - Wireless Smartphone Connectivity		•
Speakers - 4		•
Steering Wheel with Audio and Phone Controls		•
Roof Antenna	•	•

VARIANTS	LIVE	FEEL
PureTech 82	✓	✓
PureTech 110		✓
COMFORT AND CONVENIENCE		
Manual Air Conditioner with Heater	•	•
12V Socket - Front	•	•
Rear Seat - 100% fold flat	•	•
Front Windscreen Wipers - Intermittent	•	•
Bottle Holders on Doors - 1 Litre (Front & Rear)	•	•
Bag Support Hooks in Boot (3 kg)	•	•
Outside Mirrors - Manually Adjustable (Internally)	•	•
Power Windows - Front & Rear	Front Only	•
One-Touch Auto Down - All 4 Power Windows	Front Windows Only	•
Remote Keyless Entry		•
Driver seat - Manual Height Adjustable		•
Tilt Steering		•
Parcel Shelf		•
Driver And Front Passenger Seat Back Pocket		•
Co-Driver Side Sun Visor with Vanity Mirror		•
SMARTPHONE FRIENDLY		
Smartphone Storage - Rear Console	•	•
Smartphone Charger Wire Guide on Instrument Panel	•	•
USB - Front 1 + Rear 2 Fast Charger		•
INSTRUMENTATION & LIGHTING		
Digital Cluster	•	•
Tripmeter	•	•
Distance to Empty	•	•
Average Fuel Consumption	•	•
Low Fuel Warning Lamp	•	•
Gear Shift Indicator	•	•
Front Roof Lamp	•	•
Door Ajar Warning		•
SAFETY AND SECURITY		
Front Driver and Passenger Airbags	•	•
Reverse Parking Sensors	•	•
Rear Doors Manual Child Lock	•	•
Seat Belt Reminder (Driver & Co-Driver Side)	•	•
Engine Immobilizer	•	•
*High Speed Alert System	•	•
Speed Sensitive Auto Door Lock		•

T&C: ** Deco colour depends on exterior body/roof colour. *The speed alert system gives an audible warning to driver at 80 km/h and 120 km/h.

CITROËN FUTURE SURE

Citroën Future Sure is a financing plan which ensures that you enjoy unmatched comfort while owning a Citroën.

All you have to do is make one attractive monthly payment up to 5 years, which includes all your motoring expenses such as maintenance, warranty, roadside assistance, and on-road financing*.

YOU CAN CHOOSE FROM 2 OPTIONS:

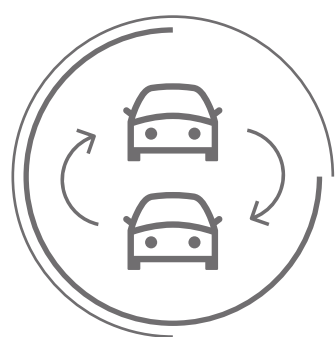

**Trade in your C3
with a new one**

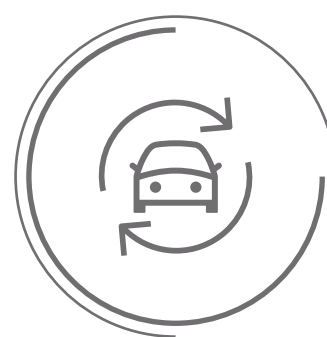

**Keep driving
your C3 by paying
the last payment
of your loan**

**That's why we call it a smart, new way to own a C3.
For more details, visit www.citroen.in**

CITROËN

360° COMFORT



PHYGITAL SHOWROOM

ATAWADAC

ANY TIME ANY WHERE ANY DEVICE ANY CONTENT
3D - CONFIGURATOR | citroen.in | SOL - SELLING ONLINE



CITROËN : FINANCE
CITROËN : INSURANCE
CITROËN : LEASE

CITROËN
SERVICE PROMISE
COMFORT AT YOUR FINGERTIPS

ANYTIME ANYWHERE ACCESS
VIRTUAL REMOTE DIAGNOSIS
PERIODIC SERVICE & MAINTENANCE WITH PICKUP & DROP
180 MINUTE RSA GUARANTEE
REMOTE SERVICE JOB CARD OPENING
SERVICE COST ESTIMATOR ON WEBSITE
GENUINE SPARE PARTS AVAILABILITY IN 24 HRS



RATE YOUR
DEALERSHIPS / PRODUCTS / SALESMEN



THE MOBILE APP
CONNECTED TO MY CITROËN



SERVICE ON WHEELS



INTERNATIONAL BRAND BORN FRENCH



INTERNATIONAL BRAND FOR INDIA



CORPORATE OFFICE ADDRESS:
PCA AUTOMOBILES INDIA PRIVATE LIMITED
Adhigattur Village, Kadambathur P.O Thiruvallur, Tamil Nadu 631203

The Citroën Customer Experience Centre
☎ 1800 267 1000 📞 +91 73585 02839

 **CITROËN**



— TO FIND OUT MORE —
visit www.citroen.in