



INSTALLATION PROCESS

Now opt for cashless & convenient toll payment.





GENERAL INSTRUCTIONS

- FASTag to be pasted on Glass Windshield from Inside of the Vehicle **on left side of IRVM while sitting at co-driver seat**
- FASTag once pasted should be clearly visible from outside and inside of the car from edge to edge
- FASTag adhering surface must be smooth and be free from oil and dust
- Never use working gloves for pasting
- **Once pasted, removal of FASTag can lead to breakage of Tag from inside and it may not function.**

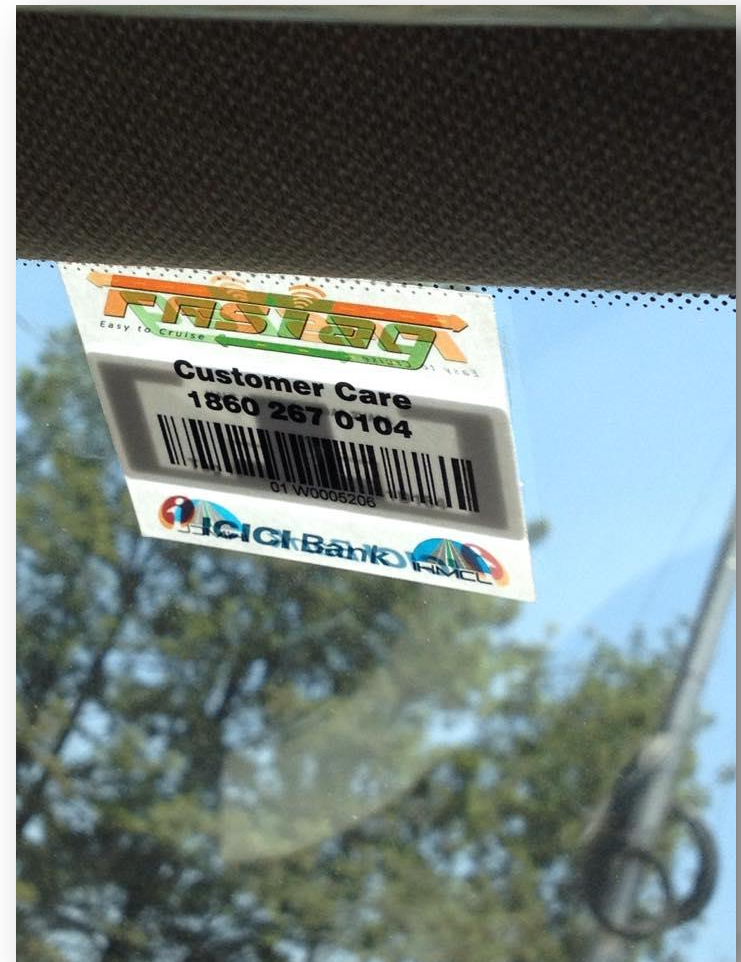

INSTALLATION PROCESS

- Clean Glass inside surface area to be dust free
- Remove protective Sheet (Release paper) from FASTag
- Put IRVM in straight position i.e. 90 degree with ground level and both sides of IRVM should be equidistant to windshield glass.
- Fix FASTag on the windshield (**co-driver side**) from inside of vehicle taking reference from IRVM.
- The detailed process of installation of FASTag on vehicle windshield is explained in subsequent slides



INSTALLATION AREA OF FASTag

- For the Purpose of Identifying the Installation Area of FASTag, all MSIL models can be classified in 2 categories
 1. Vehicles having Windshield with Straight Ceramic Line
 - ❑ Ignis, Celerio, Ertiga, Swift, Tour, Gypsy, EECO, Omni and Super Carry
 2. Vehicles having Windshield with V- Shape Ceramic Line
 - ❑ Brezza, S-Cross, CIAZ, Wagon R, Alto, K10, Dzire, Baleno



**WINDSHIELD
TYPE -1
Straight Ceramic Line**





**WINDSHIELD
TYPE -2
V Shaped Ceramic Line**

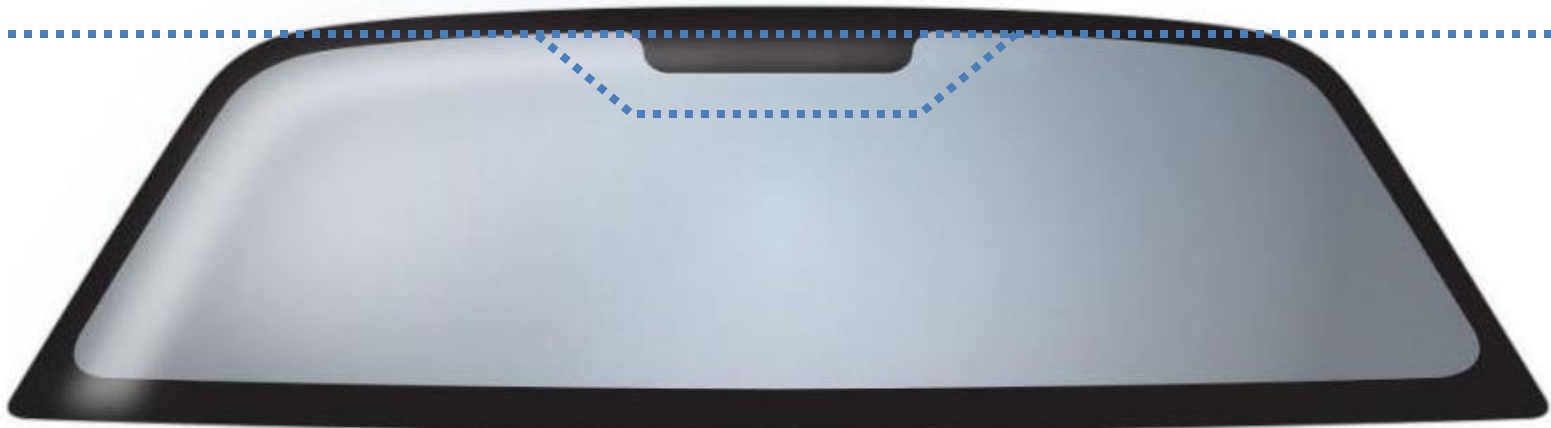

Identification of Installation Area of FASTag on Type 1 Vehicles



INSTALLATION AREA OF FASTag

To be placed towards the Centre of Windshield on the Top side but **slightly away from the edge of IRVM**

WINDSHIELD TYPE -1 Straight Ceramic Line

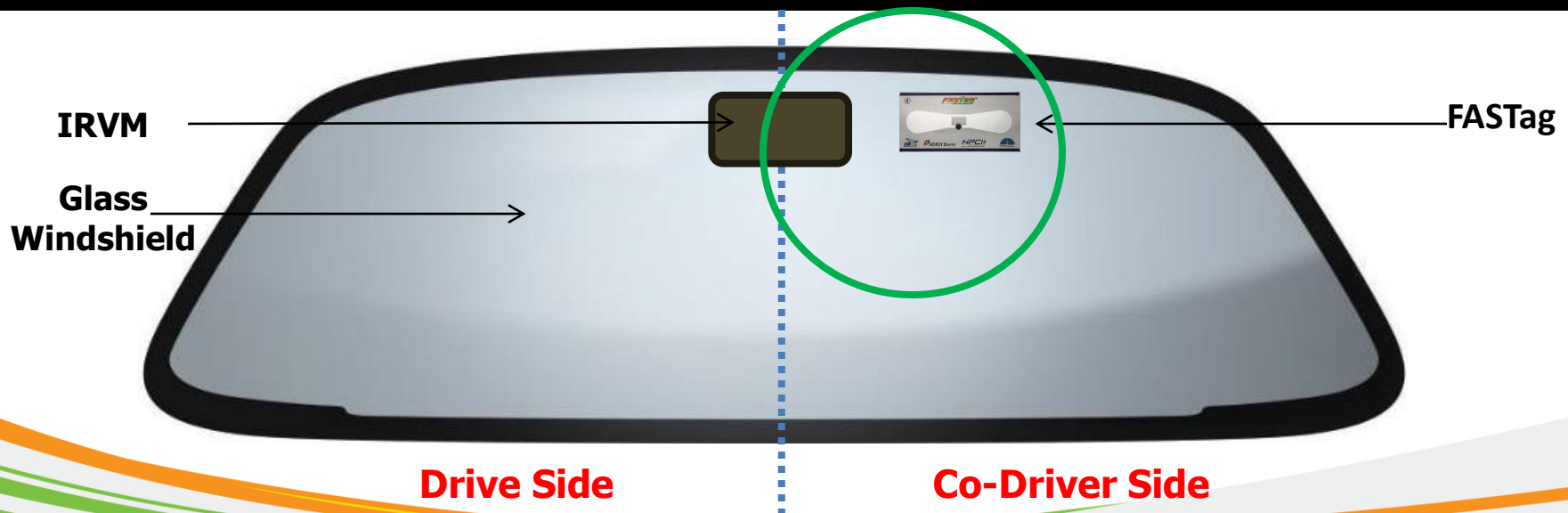

INSTALLATION AREA OF FASTag : TYPE -1

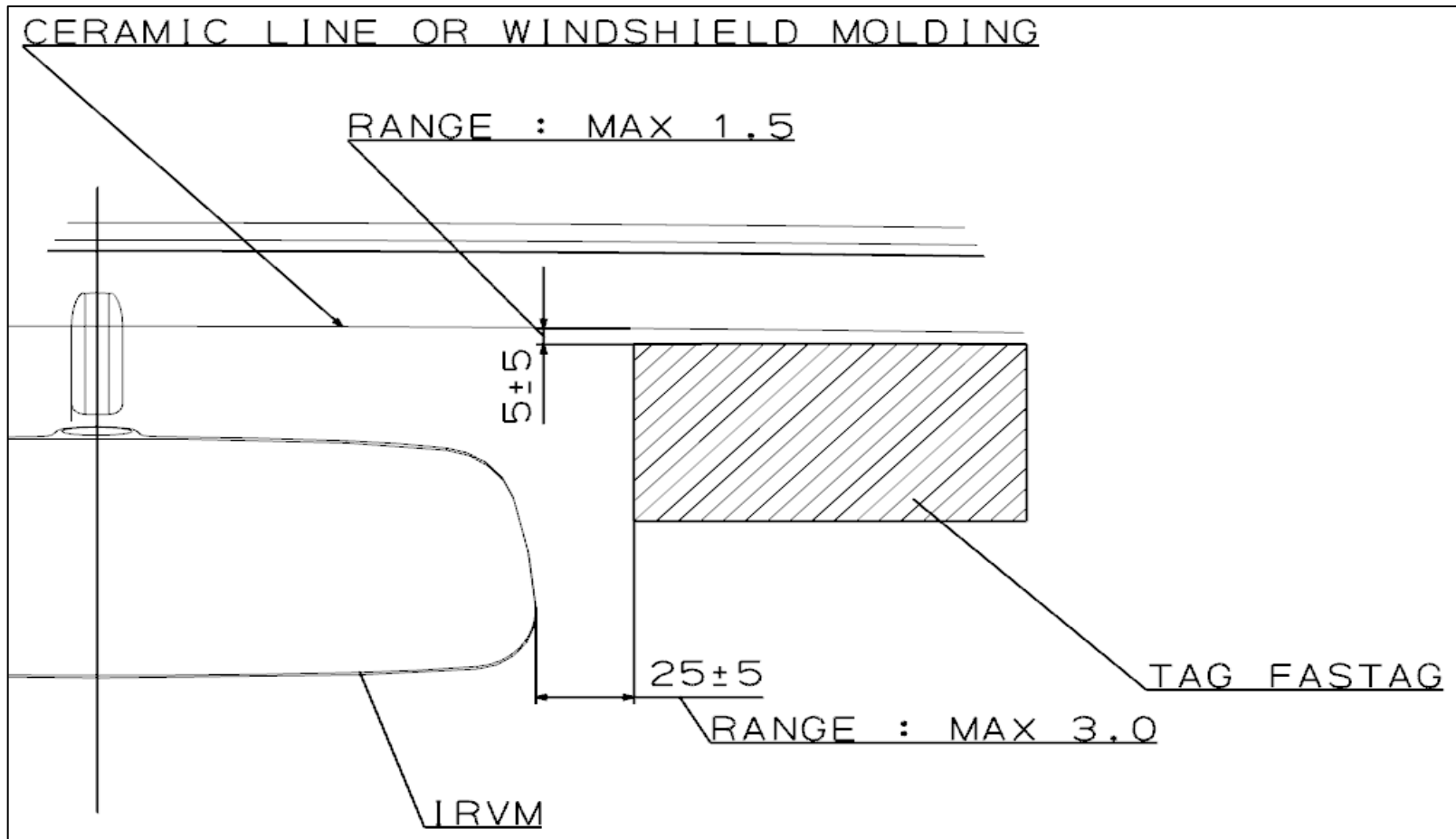

INSTALLATION AREA OF FASTag : TYPE -1

- Model wise “**Ideal Gap**” of FASTag from Edges of IRVM and Top side of Windshield Molding or Ceramic Trim

S. No.	Models	From IRVM Edge	From Ceramic Trim
1	Ignis, Celerio, Tour, Ertiga, Super Carry, Swift	25	5
2	Gypsy, EECO, Omni	40	5

* In Millimeters

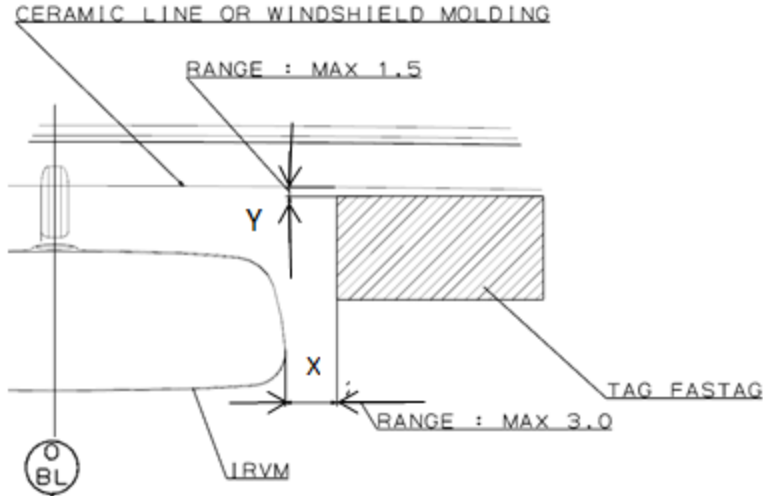

S.No.	Models	X (dist from IRVM edge)	Y (From Ceramic Trim line)
1	Dzire Tour	30	5
2	Swift	30	5
3	New Swift	40	5
4	Gypsy	40	5
5	Eeco	45	5
6	Omni	40	5
7	Super Carry	25	5
8	Ignis	25	5
9	Celerio	25	5
10	Ertiga	25	5
Tolerance on dim. (X & Y) $\pm 5\text{mm}$			

Note : In Case of Type 1 It is recommended to maintain distance “X” & “Y” as much as possible as per table mentioned.

INSTALLATION AREA OF FASTag : TYPE -1

Actual View
from Outside
of Vehicle



INSTALLATION AREA OF FASTag : TYPE -1

Actual View from
Inside of Vehicle

(sitting at Co-
driver seat)



Identification of Installation Area of FASTag on Type 2 Vehicles



INSTALLATION AREA OF FASTag

To be placed towards the Centre of Windshield on the Top side but **slightly away from the edge of IRVM** and **“NOT COVERED”** behind the **V Shaped Ceramic Line**

WINDSHIELD TYPE -2 V Shaped Ceramic Line

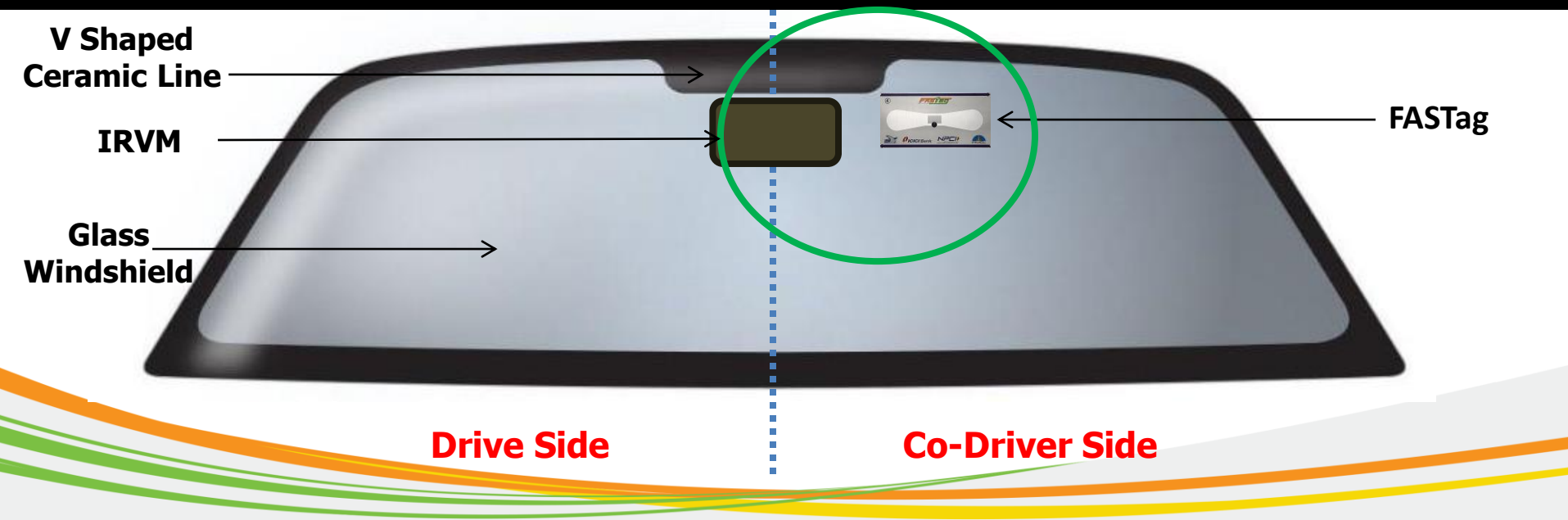

INSTALLATION AREA OF FASTag : TYPE -2

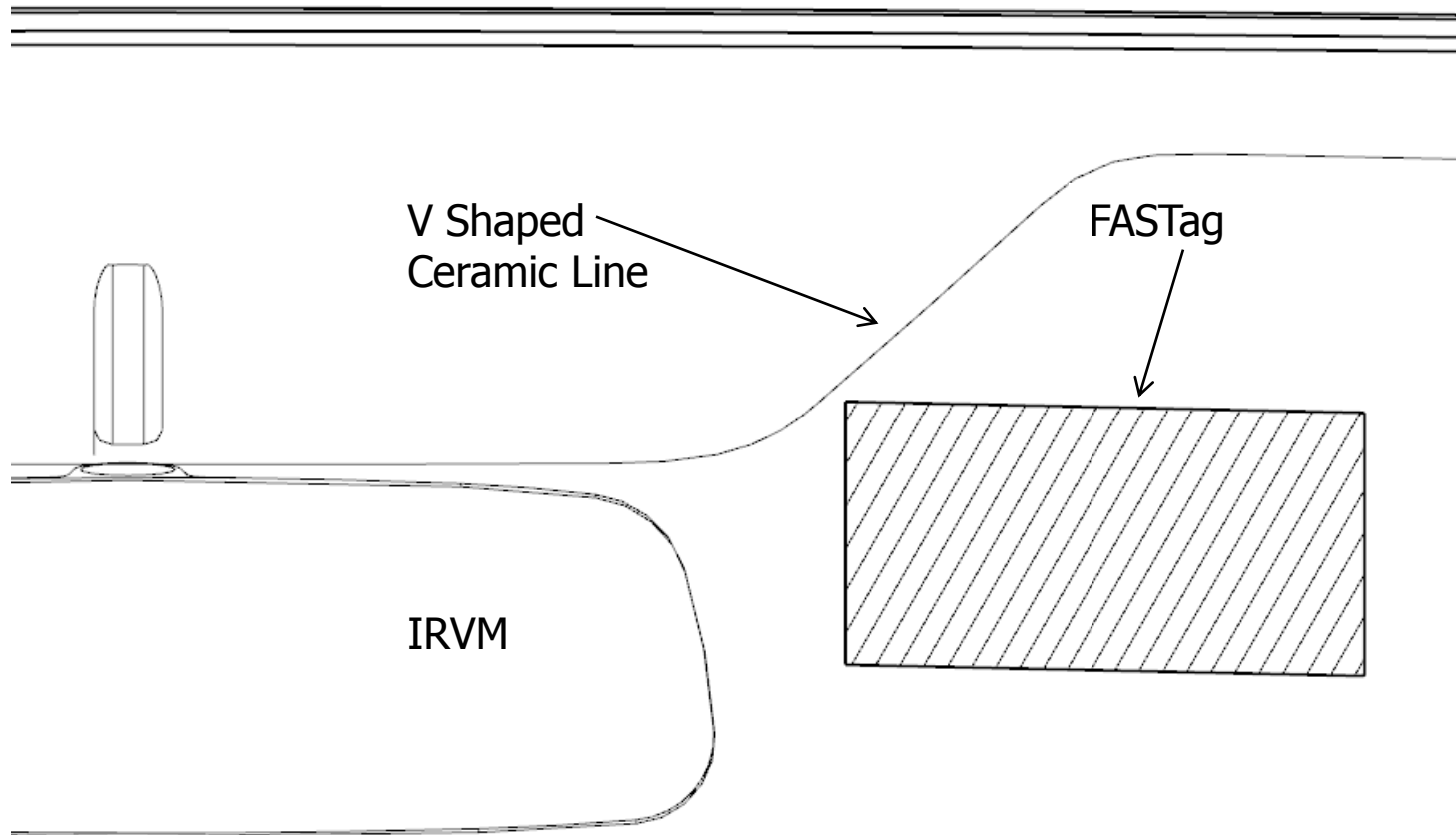

INSTALLATION AREA OF FASTag : TYPE -2

Model wise Ideal Gap of FASTag from Edge of IRVM and
“NOT COVERED” behind the V-Shaped Ceramic Line

S. No.	Models	From IRVM Edge (a)
1	Alto 800, K-10, WagonR	25
2	Ciaz, S-Cross, Brezza, Baleno, Dzire	40

Note : In Case of Type 2 vehicles also, FASTag should placed as close as possible to Ceramic Line. (maintaining distance “a” & avoiding pasting tag behind ceramic lining) - (it is recommended to maintain distance “a” & “b” as much as possible as per table mentioned in below slide.

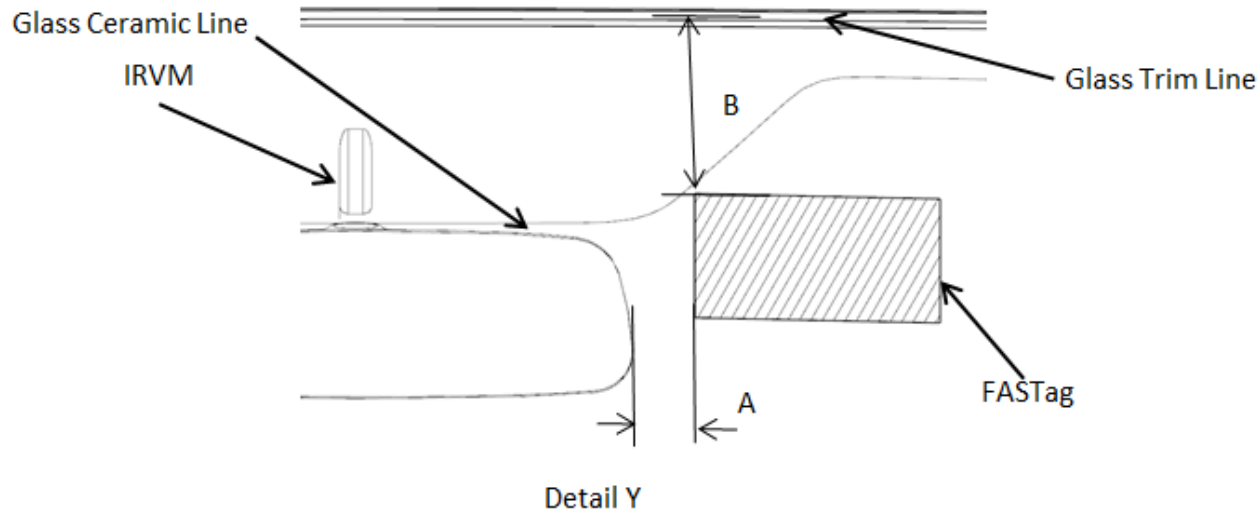

S.No.	Models	A (dist from IRVM edge)	B (From Glass TrimLine)
1	Alto 800/K-10	25	79
2	WagonR	25	83
3	Ciaz	35	107
4	S Cross	40	152
5	Vitara Brezza	40	100
6	Baleno	40	94
7	New Dzire	40	120
Tolerance on dim. (A & B) $\pm 5\text{mm}$			

INSTALLATION AREA OF FASTag : TYPE -2

Actual Picture
from Outside
of Vehicle

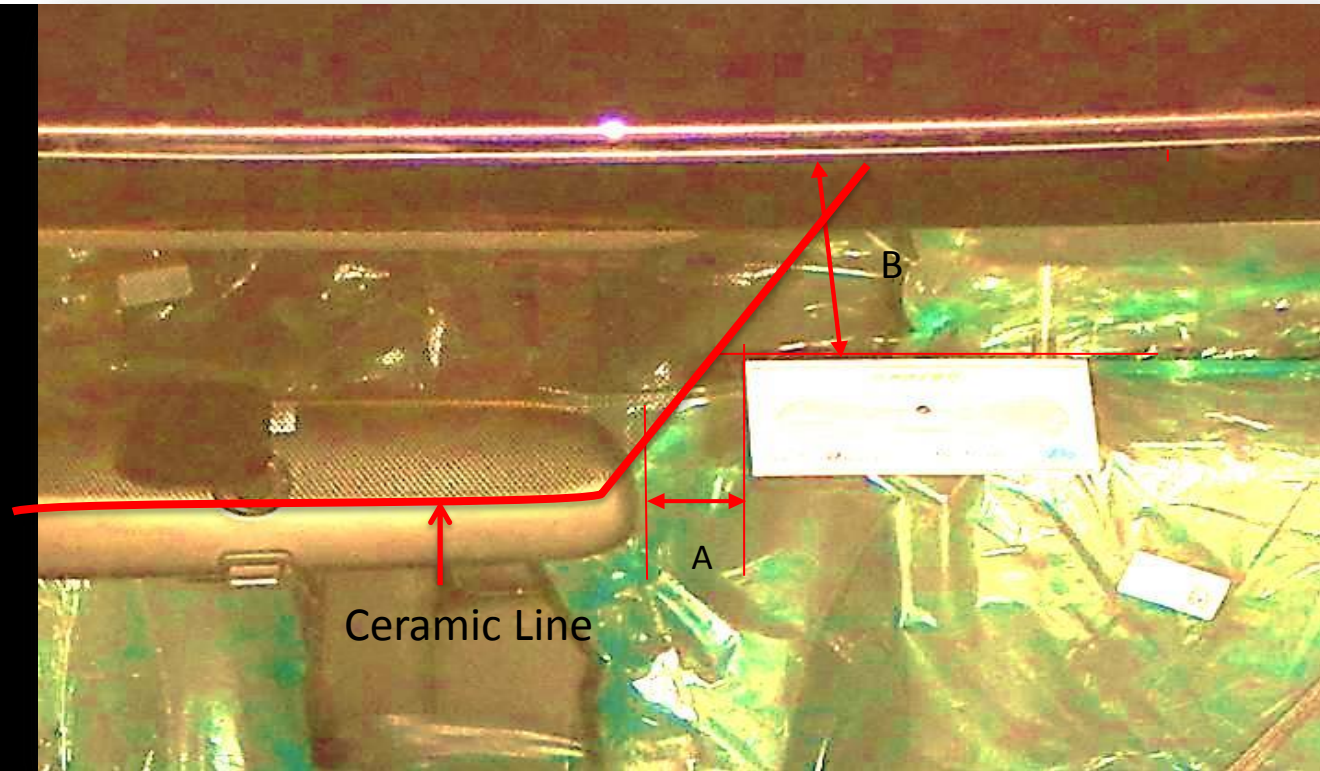

INSTALLATION AREA OF FASTag : TYPE -2

Actual View
from Inside of
Vehicle

(sitting at Co-
driver seat)

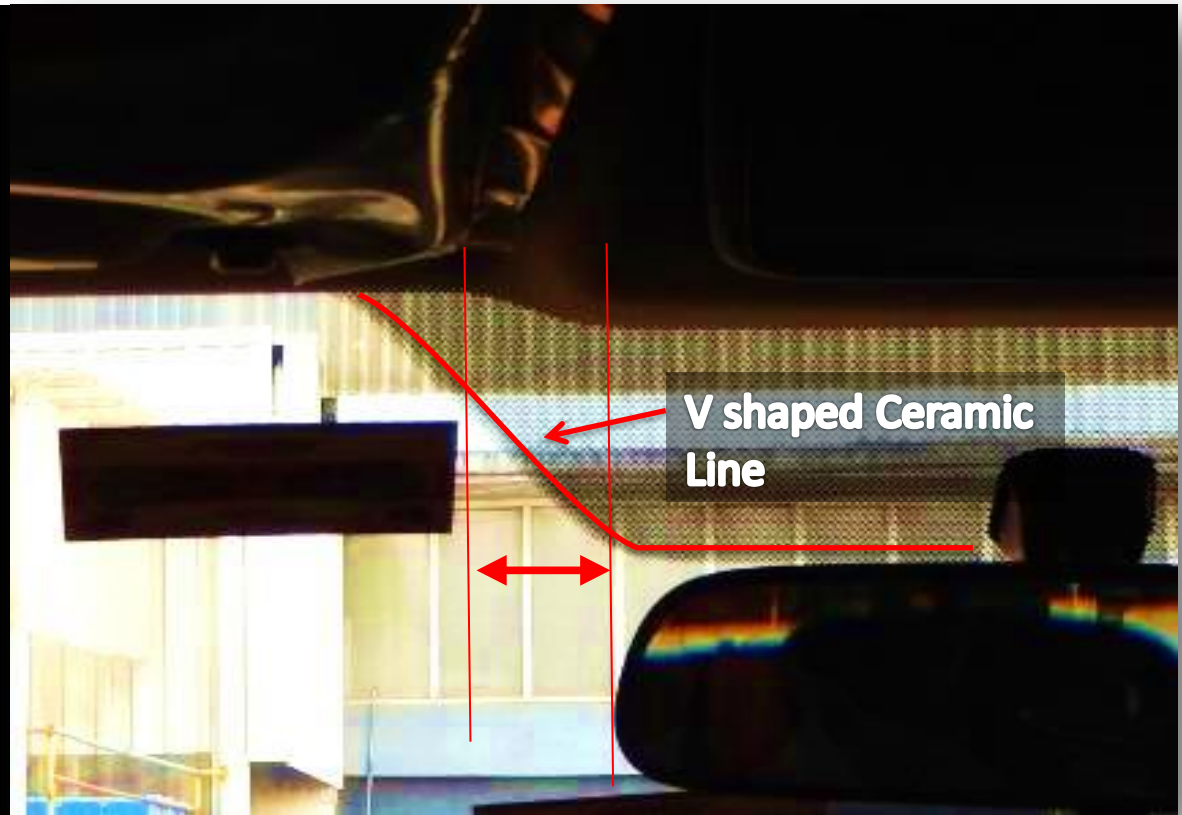

INSTALLATION AREA OF FASTag : TYPE -2



Note :

1. Once pasted, removal of FASTag can lead to breakage of Tag from inside and it may not function as per requirement. This may then have to be replaced by a NEW Tag resulting in additional cost for the Dealer

2. FASTag should **NOT BE COVERED behind the Ceramic Line as it may lead to non-detection of Tag at Toll-plaza**

DRIVE THROUGH TOLL PLAZAS LIKE A VIP.

Get your **FASTag** today

