

# Contents

## Energy management



### Models

1

Model overview

1

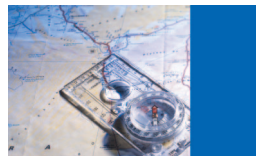

### Introduction

3

Why energy management?

3

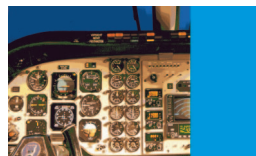

### System overview

7

System diagrams

7

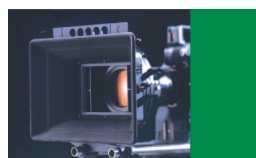

### Functions

15

Basic energy management

15

Energy management with power module

17

Energy management with micro-power module

22

Energy management with junction box

29



### System components

39

Components, energy management, power module

39

Components, energy management, micro-power module

44

Intelligent battery sensor

46

Components, energy management with junction box

49



### Service information

51

Information

51



### Summary

55



# Models

## Energy management

### Model overview

The energy management systems described here are installed in the models listed below.

<b>Models</b>	<b>Use</b>	<b>Charge voltage increase</b>	<b>Idle speed increase</b>	<b>IBS</b>	<b>Power module</b>	<b>Micro-power module</b>	<b>Junction box</b>
E52	1999 -2003	Series	Series				
E53	1999 -	Series	Series				
E60	2003 -	Series	Series	Series		Series	
E61	2003 -	Series	Series	Series		Series	
E63	2004 -	Series	Series	Series		Series	
E64	2004 -	Series	Series	Series		Series	
E65	2000 -	Series	Series		Series		
E66	2001 -	Series	Series		Series		
E67	2002 -	Series	Series		Series		
E83	2003 -	Series	Series				
E85	2001-	Series	Series				
E87 BPM	2004 -	Series	Series				Series
E87 APM	2004 -	Series	Series	Series			Series



# Introduction

## Energy management

### Why energy management?

An energy management system is used to ensure a proper energy balance in BMW vehicles.

Energy management in BMW vehicles is made up of various components which are described in the following.

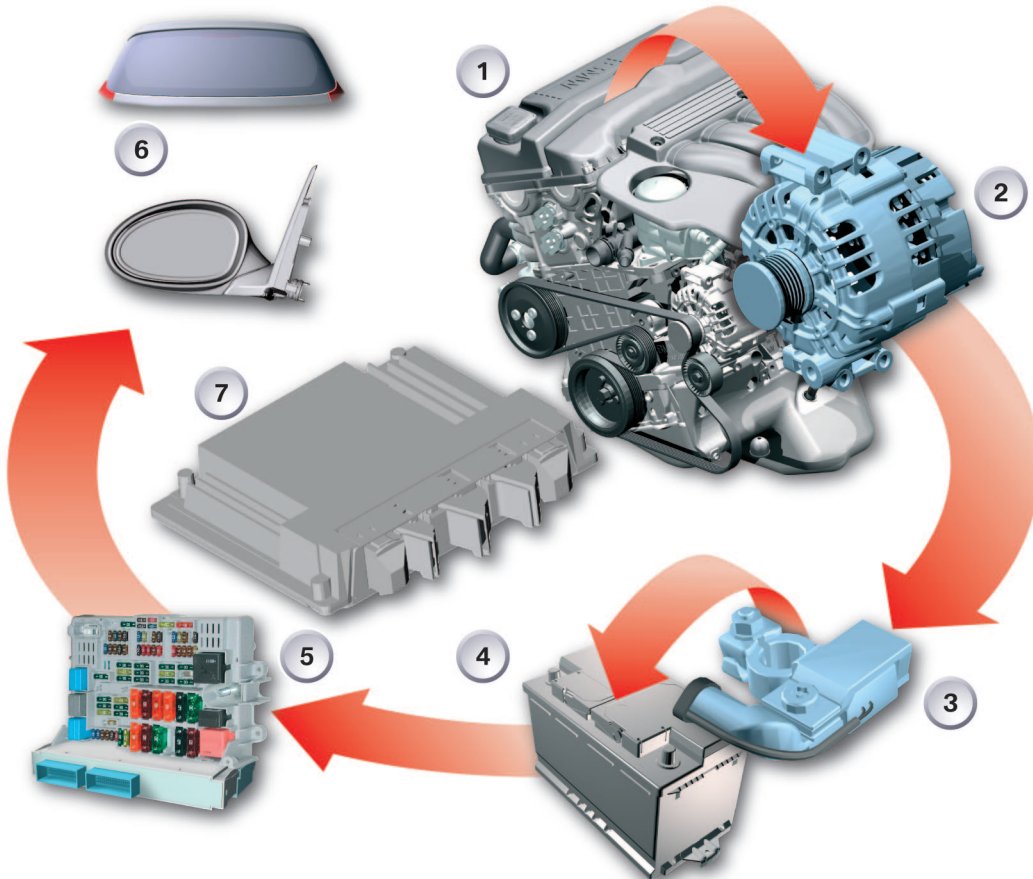

TE04-4723

1 - System components, energy management

Index	Explanation	Index	Explanation
1	Engine	5	Junction box
2	Alternator	6	Electrical load/consumer (e.g. heated rear window, heated door mirror)
3	Intelligent battery sensor	7	Engine management - power management
4	Battery		

## Power management

The main component of every energy management system is the power management software in the DME/DDE. This power management controls the flow of energy in the vehicle. The power management

in conjunction with further components forms the vehicle's energy management system.

The energy management system monitors and controls the energy balance while the vehicle is both stationary and in motion.

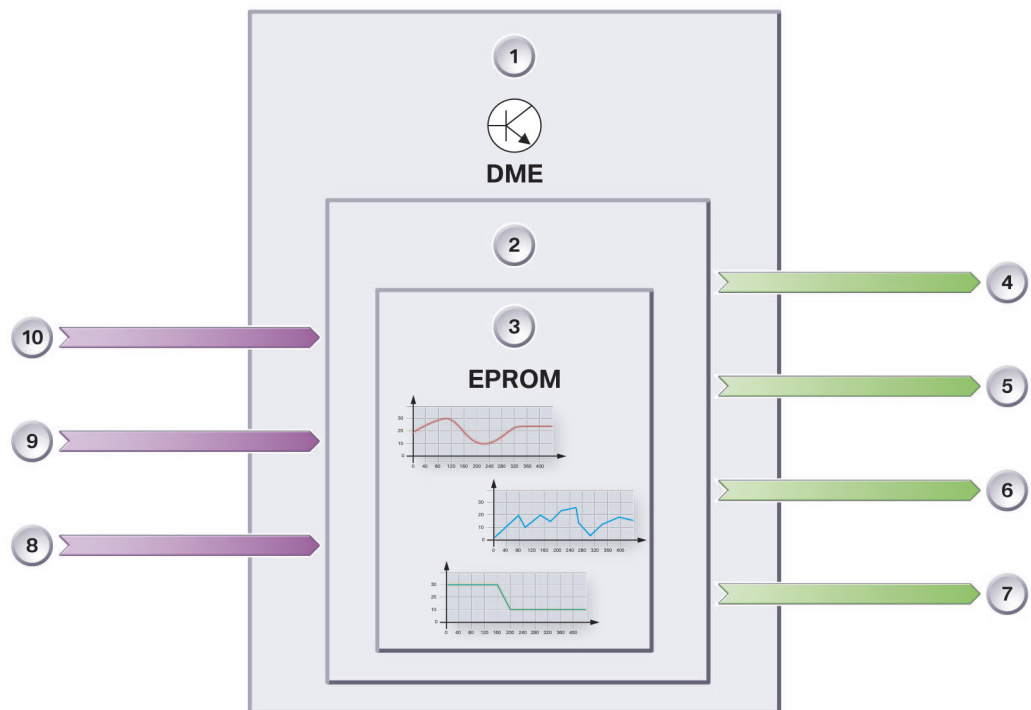

2 - Principle of power management

Index	Explanation	Index	Explanation
1	DME (Digital Motor Electronics)	6	Stationary load/consumer deactivation
2	Power management	7	Peak load reduction
3	EPROM with stored curves	8	Temperature input T
4	Idle-speed control	9	Current input $I \pm$
5	Specified charging voltage for alternator	10	Battery voltage U

The functions described in the following are integrated in the power management system and control the flow of energy in the vehicle.

## Adaptation of the alternator charging voltage

In unfavourable road situations, such as e.g. urban traffic or traffic jams, the variable battery charging voltage ensures a better battery charge balance.

The power management controls the specified voltage for the charging voltage of the alternator via the BSD line.

The specified voltage is dependent on:

- The battery temperature
- The current consumption of the vehicle.

The battery charging voltage is controlled as a function of temperature. In this way, the battery uses less water during the charging procedure and does not degas as quickly at higher outside temperatures.

## Idle speed increase

If the specified voltage on its own is no longer sufficient and the battery is showing a deficit, the DME increases the idle speed up to 750 rpm.

Criteria for increasing idle speed are:

- Alternator fully utilized
- State of battery charge is low.

## Reduction of peak loads

If the battery deficit persists in spite of the idle speed being increased, the peak loads in the vehicle are reduced.

Peak load reduction is realized by means of:

- Power output reduction, e.g. by correspondingly controlling the clock cycles of the heated rear window
- If reducing the power output is not sufficient, individual electrical loads/consumers can be switched off.

⚠ The power management in the DDE (Digital Diesel Electronics) outputs, depending on the available energy, a PWM signal (pulse width modulation) for the electric auxiliary heater in accordance with the PTC principle (Positive Temperature Coefficient). The PWM signal contains the information for the maximum switchable electric power of the electric auxiliary heater. The frequency is set at 160 Hz. ◀

## Electrical load/consumer deactivation

The loads/consumers can be categorized as follows:

- Comfort loads/consumers, e.g. heated window, seat heating, steering wheel heating.
  - These loads/consumers switch off automatically after engine "OFF" and can be activated again after the vehicle has been restarted.
- Stationary loads/consumers required by law, e.g. side lights, hazard warning lights, must be operational after engine "OFF" for a specific length of time.
  - ⚠ Legally required stationary loads/consumers are not switched off even on reaching the start capability limit of the battery. ◀
- Other stationary loads/consumers, e.g. independent heating, independent ventilation, central information display, telephone, telematic services.
  - Other stationary loads/consumers can be switched on after engine "OFF." The comfort electric loads/consumers switch off automatically on reaching the start capability limit of the battery. Switch-off is requested by the DME in the form of a CAN message.
- System-related afterrunning loads/consumers, e.g. electric radiator fan.
  - System-related afterrunning loads/consumers can maintain operation for a defined period of time.

## Battery charge balance

There are two "counters" in the power management module. One counter is responsible for the battery charge and the other for the battery discharge level. The state of charge of the battery SoC is formed by the difference between the charge acceptance and draw levels. The power management module receives the corresponding data from the IBS via the BSD line.

The power management module calculates the current SoC value on restarting the vehicle.

### State of health of the battery

When the vehicle is started, the battery terminal voltage and the starting current of the starter are measured by the IBS.

The starting current and voltage dip determined during the start phase are transferred via the BSD line to the DME/DDE. From these data, the power management module calculates the state of health (SoH) of the battery.

### Data transfer to the IBS

The following data are transferred via the BSD line to the IBS before the DME goes into sleep mode:

- State of charge of the battery (SoC)
- Outside temperature
- Available discharge level
- Terminal 15 wake-up enable
- Terminal 15 wake-up disable
- DME close

### Closed-circuit current diagnosis

A fault code is stored in the DME/DDE when the battery current exceeds a defined value during the vehicle rest phase.

## Energy management systems

Depending on the vehicle and the requirement, the functions available in the power management module are modified with various further components. This results in different energy management solutions for BMW vehicles.

The following table provides an overview of the different energy management systems and their functions.

Function	BPM	PM	MPM	JB
Charging voltage increase	X	X	X	X
Idle speed increase	X	X	X	X
Load/consumer deactivation, load		X	X	X
Load/consumer deactivation, fault			X	X
Peak load reduction		X	X	X
Closed-circuit current monitoring, partial		X		
Closed-circuit current monitoring with IBS			X	X
Battery diagnosis		X	X	X

**BPM** = Basic Energy Management (E53, E87)

**MPM** = Micro-power Module (E60-E64)

**PM** = Power Module (E65-E67)

**JB** = Junction Box (E87, E90)





# System overview

## Energy management

### System diagrams

The power supply is shown in the form of block diagrams in this chapter.

The following block diagrams are depicted:

- System diagram with micro-power module
- System diagram with power module
- System diagram with junction box

## System diagram with micro-power module

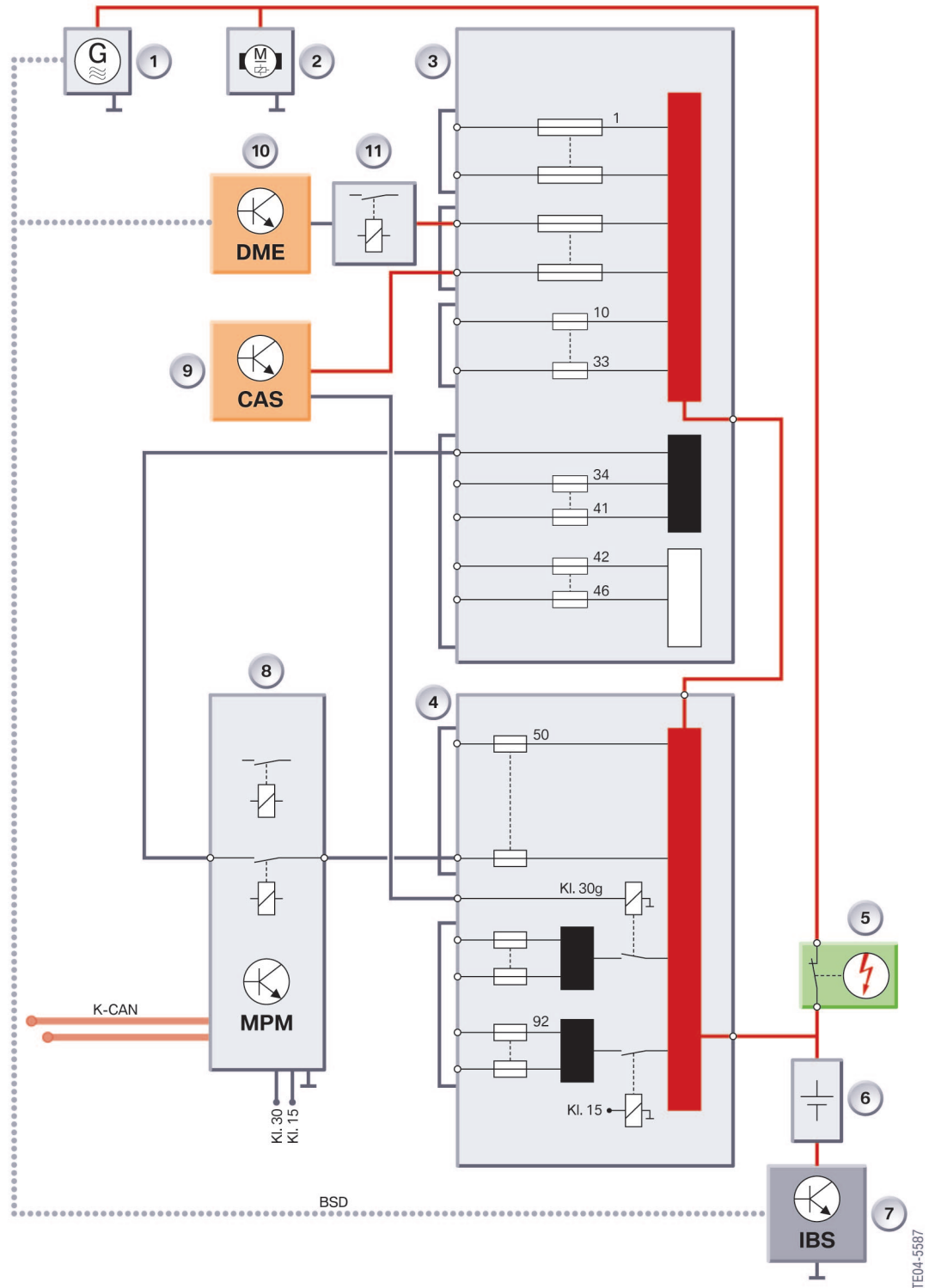

1 - Electrical energy management with micro-power module, e.g. E60

TE04-5587



<b>Index</b>	<b>Explanation</b>	<b>Index</b>	<b>Explanation</b>
1	Alternator	7	Intelligent battery sensor
2	Starter	8	Micro-power module
3	Front power distribution box	9	CAS (Car Access System)
4	Rear power distribution box	10	DME (Digital Motor Electronics)
5	Safety battery terminal	11	DME main relay
6	Battery		

## System overview, power module

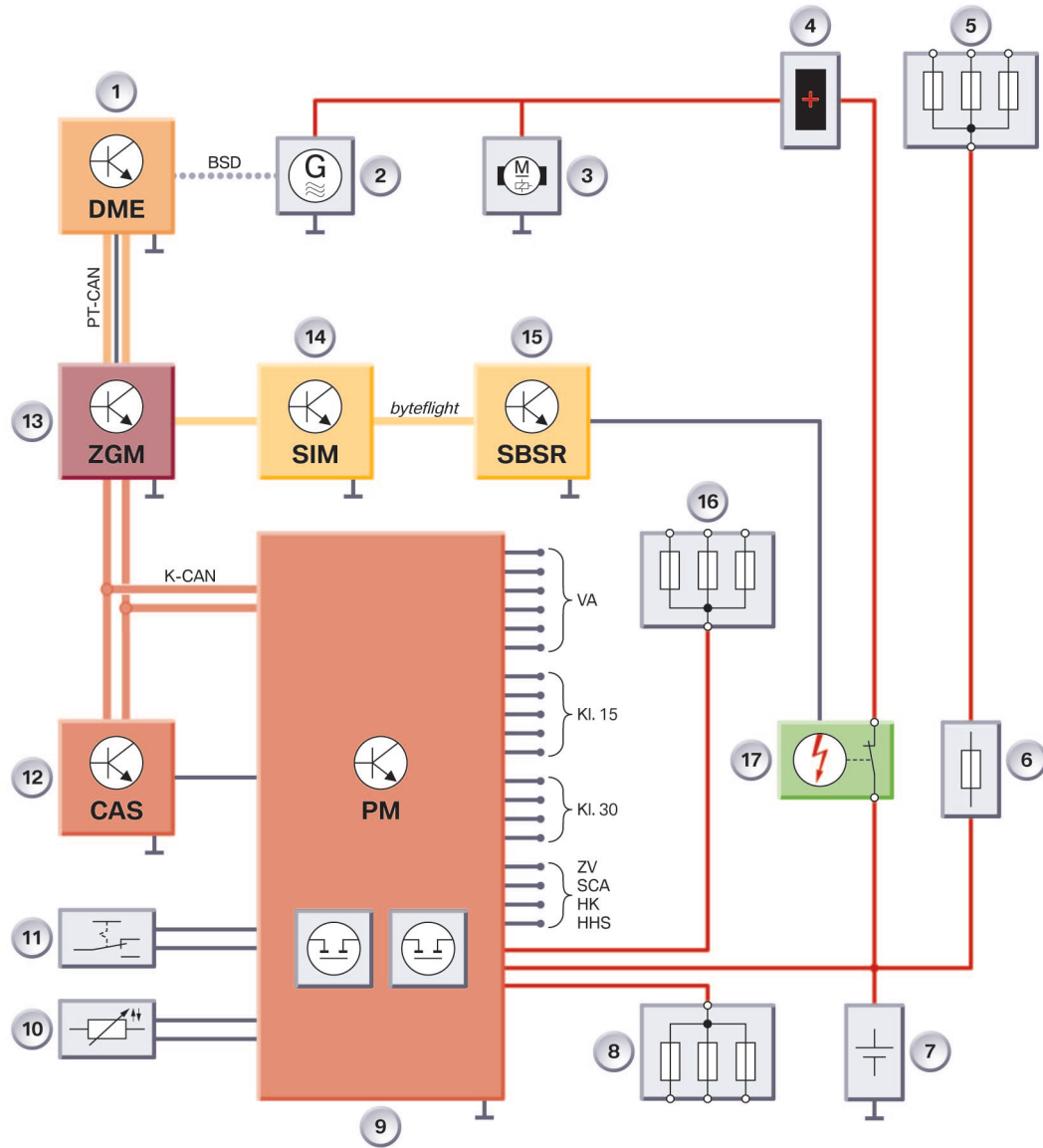

2 - System overview, E65 power module

TE04-5607

<b>Index</b>	<b>Explanation</b>	<b>Index</b>	<b>Explanation</b>
1	DME (Digital Motor Electronics)	10	Temperature sensor
2	Alternator	11	Battery switch
3	Starter	12	CAS (Car Access System)
4	Jump-start terminal point	13	ZGM (central gateway module)
5	Fuse carrier, engine compartment	14	SIM
6	Main fuse	15	SBSR
7	Battery	16	Fuse carrier, glovebox
8	Fuse carrier, luggage compartment	17	Safety battery terminal
9	Power module		

## Energy management with junction box

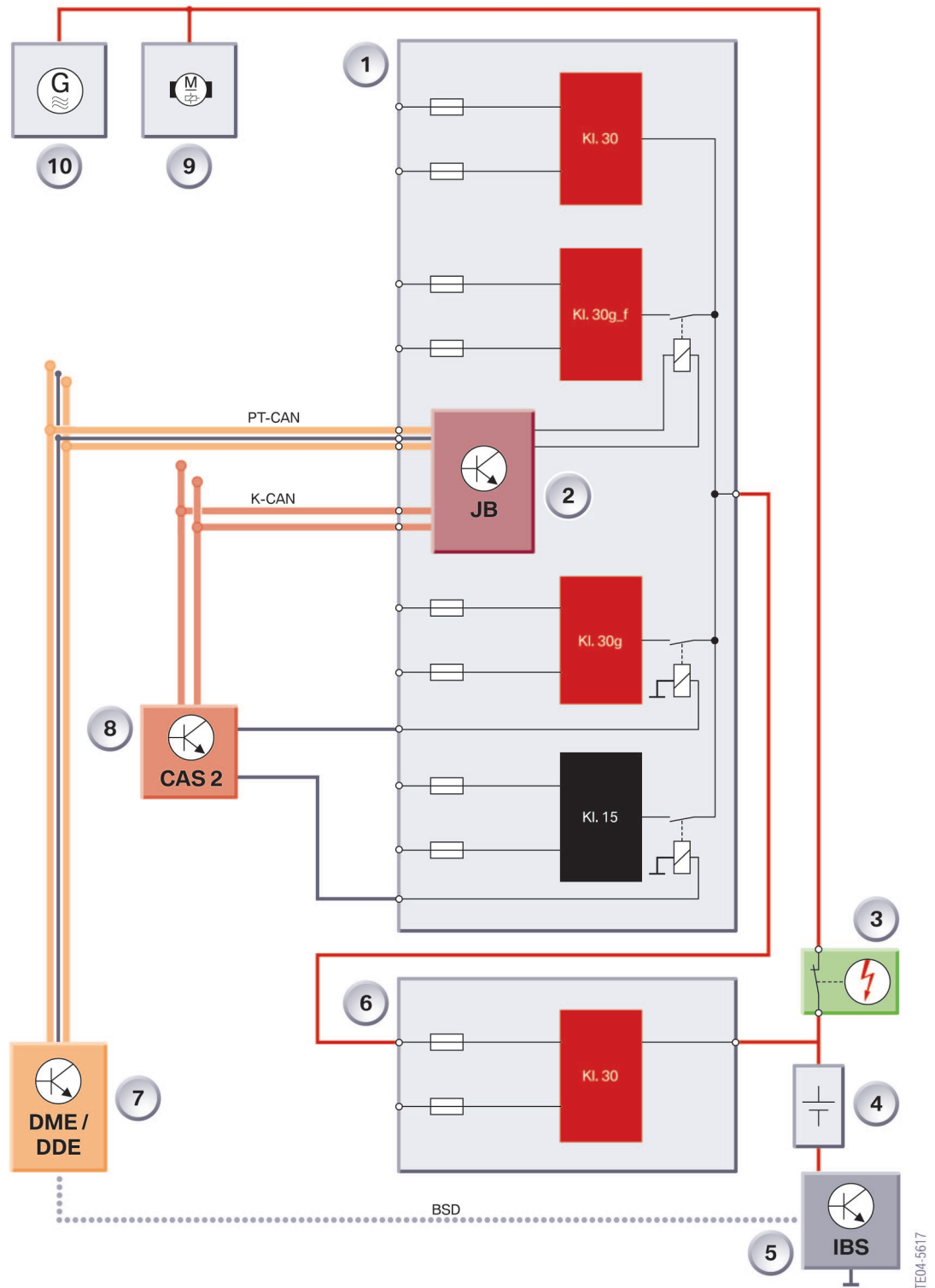

3 - Energy management, E87 junction box

TE04-5617

<b>Index</b>	<b>Explanation</b>	<b>Index</b>	<b>Explanation</b>
1	Front power distribution box	7	CAS (Car Access System)
2	Junction box	8	Starter
3	Safety battery terminal	9	Alternator
4	Battery	Kl. 30	Continuous positive
5	IBS (Intelligent Battery Sensor)	Kl. 30g_f	Switched positive, fault-dependent
6	Rear power distribution box	Kl. 30g	Switched positive, time-dependent
7	DME (Digital Motor Electronics)	Kl. 15	Ignition





# Functions

## Energy management

### Basic energy management

#### Vehicles with BSD (bit-serial data interface)

Basic energy management is used in current BMW vehicle types with a BSD interface.

The main component of basic energy management is the software integrated in the DME/DDE for controlling the charging voltage. The specified charging voltage can be increased in the event of increased current consumption in the vehicle electrical system.

The specified charging voltage is transmitted via a bit-serial interface from the DME/DDE to the alternator.

The energy management system also features the option of load/consumer deactivation. The power output of the heated rear window can be reduced in the event of excessive current consumption in the vehicle.

The charging voltage can be regulated as a function of the outside temperature. This enables the battery to be charged to optimum effect.

At cold temperatures the charging voltage can be increased in order to achieve a higher capacity.

At high temperatures the charging voltage is reduced in order to avoid excessive gassing. The maximum charging voltage is 14.8 V.

#### Idle speed increase

If current is drawn from the battery in stationary operation with the alternator operating at maximum, the idle speed is increased by a maximum of 200 rpm on vehicles with petrol/gasoline engines.

The higher transmission ratio between the engine and the alternator renders this intervention unnecessary in the case of diesel engines. The alternator is already running with sufficiently high revs.

#### Load/consumer deactivation

Some loads/consumers can remain switched on even when the vehicle has stopped. In the interests of protecting the battery, these loads/consumers are deactivated after terminal R "OFF" with a delay of 16 minutes or immediately with the "Go to Sleep Mode" diagnosis telegram.

Load/consumer deactivation is coded in such a way that it responds immediately when the following conditions are satisfied:

- Terminal R "OFF"
- Central double-locking engaged
- All doors, engine bonnet/hood, rear lid and rear window on the Touring are closed

Load/consumer deactivation is cancelled and the delay time restarted each time there is a change at specific input signals.

Load/consumer deactivation is handled as above if one of these conditions is missing.

In the interests of reducing current consumption by the ZKE (central body unit), the ZKE switches after certain conditions to a rest state in which only restricted functions are possible.

The following must be deemed preliminary conditions for sleep mode:

- Terminal 30 passive
- Power windows, central locking, remote control and anti-theft alarm system passive

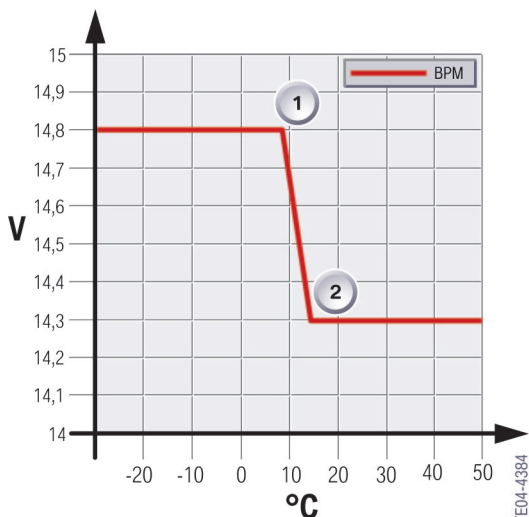

1 - Charging voltage increase

Index	Explanation
1	Increased charging voltage
2	Normal charging voltage



The system switches to sleep mode

- 1 second after power windows deactivated, load/consumer deactivation, interior lights passive, no diagnosis mode and the K-bus in "Sleep" status
- 1 second after the Go to Sleep Mode telegram

Sleep mode is quit again when:

- Signal change occurs at a status field with a signal identified with "Wake Up"
- A valid remote control signal is detected
- The K-bus is activated

The functions must then be categorized as passive if actions such as holding or delay times are no longer active

### **Emergency operation functions**

If the BSD is interrupted or faulty, the following emergency operation functions are activated:

- No load/consumer deactivation
- Constant charging voltage (14.3 V)
- Fault memory entry "Bus communication BSD"

# Energy management with power module

## Power module

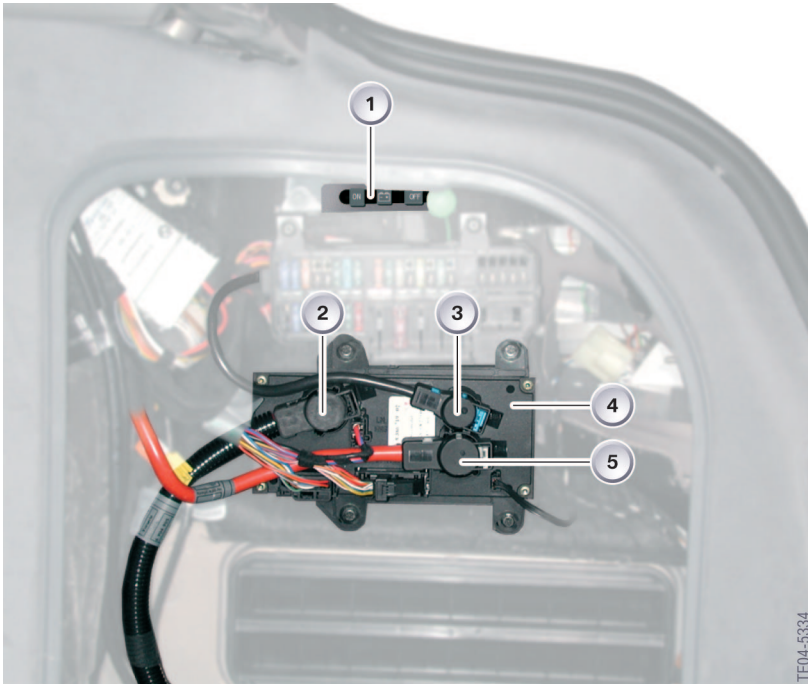

2 - Power module in luggage compartment, rear right

Index	Explanation	Index	Explanation
1	Battery switch	4	Power module
2	Battery positive cable	5	Terminal 30B
3	Terminal 30U		

The functions listed below are integrated in the power module are form part of energy management for the BMW E65/E66/E67 vehicle type:

- Optimum battery charging
- Load-side peak reduction
- Deactivation of stationary loads/consumers
- Load/consumer deactivation
- Closed-circuit current monitoring
- Distribution mode
- Automatic electrical system disconnection
- Electronic fuse
- Central battery voltage specification
- Heated rear window
- Interior lights
- Rear lid and fuel tank flap control
- Information memory
- Limp home properties
- Check Control message
- Diagnosis

## Optimum charging

The battery voltage can vary between 14.0 V and 15.5 V. The optimum charging voltage is set by the power module as a function of the state of charge of the battery, the battery temperature and the lamp resistance. The maximum charging voltage is 16 V.

### Detection of state of charge of battery

The power module detects the state of charge of the battery at all times by calculating the battery current while the vehicle is moving and by measuring the discharge current.

When the vehicle is stationary, the state of charge is recalculated by means of a closed-circuit voltage measurement at the battery and adopted.

### Charging voltage as a function of battery temperature

The alternator charging voltage is set as a function of the battery temperature using the charging curve stored in the power module.

The power module detects the temperature of the battery and sends the message "Charging voltage increase" to the K-CAN PERIPHERALS. The CAS forwards the message to the K-CAN SYSTEM.

The central gateway module receives the message and forwards it to the PT-CAN. The Digital Motor Electronics receives the request to increase the charging voltage via the PT-CAN.

The alternator receives the request to increase the charging voltage via the BSD line. The electronic evaluation unit in the alternator sets the requested charging voltage.

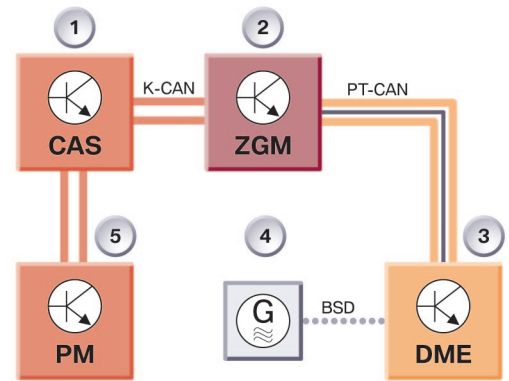

3 - Data flow, power module/alternator

Index	Explanation
1	CAS (Car Access System)
2	ZGM (central gateway module)
3	DME (Digital Motor Electronics)
4	Alternator
5	Power module
BSD	Bit-serial data interface

### Idle speed increase

As little energy as possible is drawn from the battery in the interests of improving the charge balance. The idle speed is increased early in order to prevent an increased draw of energy. This ensures that the battery has a higher state of charge.

If this drops below the calculated start capability of the battery, the idle speed is increased to 750 rpm.

---

## Peak reduction

### Load-side peak reduction

If while the engine is running a battery discharge (in spite of increased idle speed) is detected, loads/consumers are reduced or deactivated in stages in accordance with a priority table.

These loads/consumers are:

- Heated rear window
- Seat heating
- Heater fan (without defrost function)
- Steering wheel heating
- Mirror heating
- Wiper console heating

---

## Load/consumer deactivation

### Deactivation of stationary loads/consumers

In order to safeguard the start capability of the vehicle, the state of battery charge is also monitored when the vehicle is stopped.

A minimum state of charge is determined in order to guarantee start capability. This is dependent on:

- The measured temperature of the last few days
- The engine type
- The capacity of the installed battery

If the state of charge approaches this limit value because a stationary load/consumer is active, the power module prompts this load/consumer to switch itself off.

The following are stationary loads/consumers:

- AHM (Trailer module)
- CD (Colour Display)
- DWA (Anti-theft alarm system)
- LSZ (Light switch centre)
- EGS (Electronic transmission control)
- IHKA (Integrated automatic heating/air conditioning)
- SH (Independent heating)

### Load/consumer deactivation

In order that the battery is not discharged in the event of a permanent activation of loads/consumers, a central load/consumer deactivation is performed 16 minutes after terminal R off.

These loads/consumers are:

- IB (Interior lights)
- VA\_K (Load/consumer deactivation, body area)
- VA\_D (Load/consumer deactivation, roof area)

### Load/consumer deactivation in event of undervoltage

In the event of an undervoltage due to high loads, the power module transmits a message to increase idle speed and for load/consumer deactivation after the voltage drops below 10.5 V (for 5 seconds). Load/consumer deactivation is conducted in accordance with the priorities stored in the power module.

The power outputs of the power module are deactivated at the same time.

These loads/consumers are:

- IB (Interior lights)
- VA\_K (Load/consumer deactivation, body area)
- VA\_D (Load/consumer deactivation, roof area)

## Closed-circuit current monitoring

The closed-circuit current monitoring function is activated in the power module when the battery switch is set to ON.

The power module switches to the closed-circuit current monitoring function at terminal 0 after 60 minutes. Closed-circuit current monitoring begins again if an action on the vehicle (e.g. central locking, open rear lid) occurs before a period of 60 minutes has elapsed.

After this period has elapsed the closed-circuit current must not exceed 80 mA. If however the closed-circuit current is higher than 80 mA, the message "Shutdowncounter" is sent by the power module after 5 minutes. After a further 90 seconds disconnection of the vehicle electrical system is completed for 5 seconds.

Disconnection is repeated if the closed-circuit current after reactivation is still higher than 80 mA.

If the closed-circuit current is still higher than 80 mA, permanent disconnection is

performed by the electronic battery master switch.

The fault (incl. boundary conditions and the reason for the increased closed-circuit current) is set in the power module's fault memory.

When the terminal 15\_w signal is detected, the electronic battery master switch is closed and a Check Control message "Increased closed-circuit current" is displayed.

Closed-circuit current monitoring is cancelled by the message Side lights ON and hazard warning lights. The loads/consumers required by law must not be deactivated.

### Automatic electrical system disconnection

The battery is disconnected from the vehicle electrical system after a period of 3 weeks without a request for a function. This prevents the battery from being exhaustively discharged.

## Distribution mode

By repositioning the battery switch, the power module switches to the Distribution mode function 30 minutes after terminal R off. Prior to disconnection the message "Shutdown" is sent by the power module. Disconnection is completed after a further 90 minutes.

After ignition lock position terminal R ON a Check Control message is sent which alerts the driver that the vehicle is in Distribution mode. The message "Battery switch OFF" appears.

The electronic battery master switch is closed when the terminal 15\_w signal is detected or by repositioning the battery switch to "closed-circuit current monitoring".

 The vehicle can also be started and driven in Distribution mode. All the systems are operational. The Check Control message remains active. With terminal R Off, disconnection is initiated again after 30 minutes, as described above. ◀

## Fuses/specifications

### Electronic fuses

The electronic battery master switch is opened when a short-circuit current in excess of 250 A is detected. Only after the terminal 15\_w wake-up signal from the CAS is detected is an attempt made to close the electronic battery master switch.

The procedure is repeated until the short circuit is eliminated.

### Central battery voltage specification

The power module measures the battery voltage continuously. This voltage is made available to all the other electronic control units via their bus connection. This facilitates for example a continuous operation of the slide/tilt sunroof irrespectively of the battery voltage.

There are no individual measurements of the individual control units with central battery voltage specification.

### Heated rear window

The electronic output stage of the heated rear window in the power module is activated by a

K-CAN message from the IHKA control unit "Heated rear window ON".

---

## Outputs

### Interior lights

The interior lights are divided into three outputs (groups).

- IB (Interior lights)
- VA\_K (Load/consumer deactivation, body area)
- VA\_D (Load/consumer deactivation, roof area)

The interior lights are controlled by the power module.

VA\_K and VA\_D are switched as a function of the corresponding ON/OFF contacts.

### Rear lid and fuel tank flap control

The power module controls the functions of the body electronics in the area of the rear lid:

- Rear lid lock
- Rear lid Soft Close Automatic
- Fuel tank flap locking

The necessary software, such as e.g. switch-on times and repeat interlocks, is integrated in the power module.

### Anti-theft alarm system

The power module is used to monitor the rear lid via the SCA contact of the anti-theft alarm system.

---

## Memory and properties

### Information memory

Vehicle-related data are stored in the information memory. These data make it possible to indicate the status of the load and service life of the battery. The information memory can be read out by way of diagnosis.

### Battery temperature sensor

A substitute value of 20 °C is accepted in the event of an open circuit, a short circuit or an implausible value. This corresponds to a fixed charging voltage of 14.3 V at the battery.

The battery capacity can now only be calculated under limited conditions.

### Battery switch

The system switches to closed-circuit current monitoring if the battery switch is fault-free.

### Terminal 15\_w

The following signals prevent deactivation of the power module without terminal 15\_w:

- Terminal 15 (via CAS bus connection)
- Vehicle speed > 2 km/h via DSC bus connection (Dynamic Stability Control)
- System voltage > 13.2 V (PM central voltage specification)

## Energy management with micro-power module

The energy management system with the micro-power module is used in the E60, E61, E63, E64. Energy management has the same basic functions as power management in the DME/DDE. Energy management with the micro-power module differs from the E65 power module in the following details:

- Permanent monitoring of the charge/discharge current by the intelligent battery sensor
- Terminal 15 wake up
- Load/consumer deactivation time-controlled by terminal 30g relay
- Load/consumer deactivation fault-controlled by micro-power module.
- Closed-circuit current diagnosis and violation of fault storage

### Intelligent battery sensor

The intelligent battery sensor IBS is a mechatronic component. The IBS with its own microcontroller continually measures the following:

- The battery terminal voltage
- The battery charge/discharge current
- And the battery acid temperature

#### Measuring ranges of IBS

Voltage	6 V to 16.5 V
Current	- 200 A to + 200 A
Closed-circuit current	0 A to 1000 A
Starting current	0 A to 1000 A
Temperature	- 40 °C to 105 °C

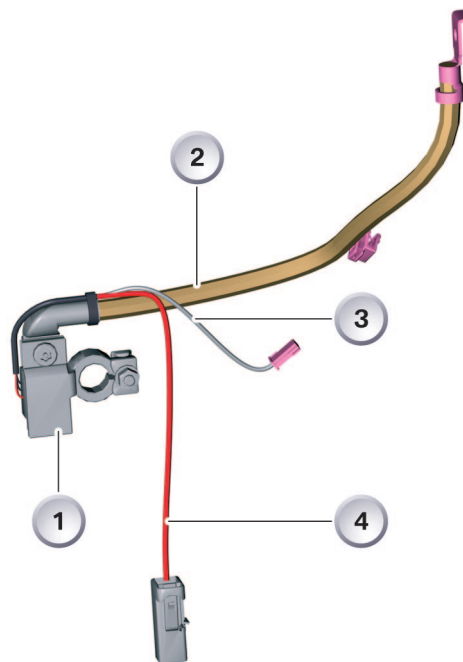

4 - Intelligent battery sensor

#### Index Explanation

1	Intelligent battery sensor
2	Ground cable
3	Bit-serial data interface (BSD)
4	Connection B+

The IBS is located directly on the battery negative terminal and can thus be used for many BMW vehicle types.

The intelligent battery sensor (IBS) is part of the power management system. The IBS can be used to determine precisely the "state of charge" (SoC) and the "state of health" (SoH) of the battery.

TE04-4562



## Functional principle of IBS

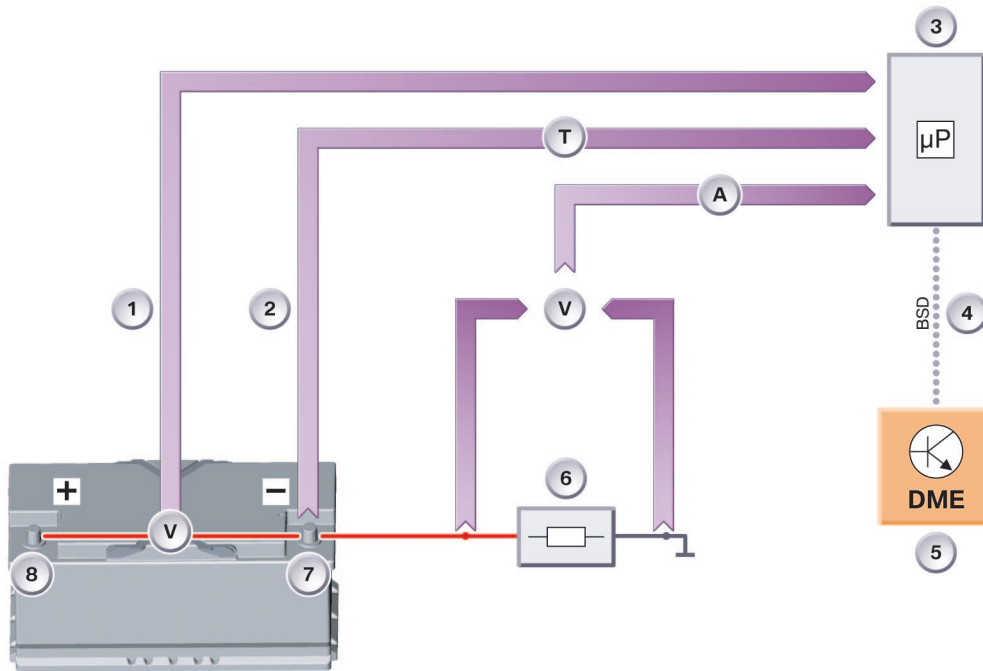

TE04-5584

5 - IBS functional principle

Index	Explanation	Index	Explanation
1	Battery voltage measurement	5	Digital Motor Electronics DME
2	Battery temperature measurement	6	Current measurement (voltage drop at shunt)
3	Microcontroller in IBS	7	Negative pole of battery
4	Bit-serial data interface	8	Positive pole of battery

The software in the IBS controls the process and communication with the DME (Digital Motor Electronics) / DDE (Digital Diesel Electronics) control units. The IBS sends the data via the bit-serial data interface (BSD) to the DME/DDE. The following functions are integrated in the IBS:

- Continuous measurement of the battery current, voltage and temperature under all vehicle operating conditions.
  - When the vehicle is stationary, the measured values are interrogated cyclically every 40 s to save power. The measuring period of the IBS is approx. 50 ms. The measured values are entered in the closed-circuit current histogram in the IBS.
- The state of battery charge (SoC) is partly calculated.
  - The DME/DDE reads out the closed-circuit current histogram after the vehicle is restarted. A corresponding entry is made in the fault code memory of the DME/DDE if a closed-circuit current infringement is determined.
- The IBS sends the data via a bit-serial data interface to the DME/DDE.
- Calculation of the battery indicators as the basis for the state of charge (SoC) and state of health (SoH) of the battery.
  - The battery indicators are charge and discharge current, voltage and temperature of the vehicle battery.

- Balancing of the charge and discharge currents of the battery.
- Permanent monitoring of the state of battery charge.
  - Transmission of data in the event of a deficit
- Calculation of the current progression when starting the engine to determine the state of battery health.
- Closed-circuit current monitoring of the vehicle.

### Charge management by the IBS

The IBS continuously balances the state of battery charge even when the vehicle is stationary.

The current SoC is stored in the IBS every 2 hours. 3 locations are reserved in the memory for this purpose. The first entry is made at location 1, locations 2 and 3 are overwritten every 4 hours.

From terminal 15 "On" the DME/DDE updates the value to the current values of the battery indicators.

### Terminal 15 wake up

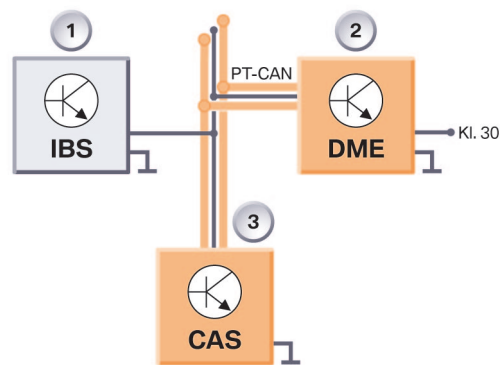

6 - Terminal 15 wake up

TED4-5335

Before the DME/DDE assumes sleep mode, it informs the IBS of the current SoC of the battery. The IBS sends the wake-up signal when the available SoC is used up.

The DME/DDE obtains information on the current SoC of the battery from the IBS. The IBS informs the DME/DDE when the SoC of the battery is critical.

The DME/DDE requests the stationary electrical loads/consumers to switch off. The DME/DDE no longer permits the IBS to wake the vehicle.

The vehicle subsequently reassumes sleep mode.

The wake-up function only applies when the vehicle is at rest.

Index	Explanation
1	Intelligent battery sensor
2	Digital Motor Electronics DME
3	Car Access System CAS

## Terminal 30g relay

In order to ensure a proper energy balance and battery start capability, specific stationary loads/consumers are deactivated by the terminal 30g relay after a prespecified period of time.

The terminal 30g relay is activated by the Car Access System CAS and effects a defined deactivation of loads/consumers.

The terminal 30g relay is installed in the power distribution box in the luggage compartment.

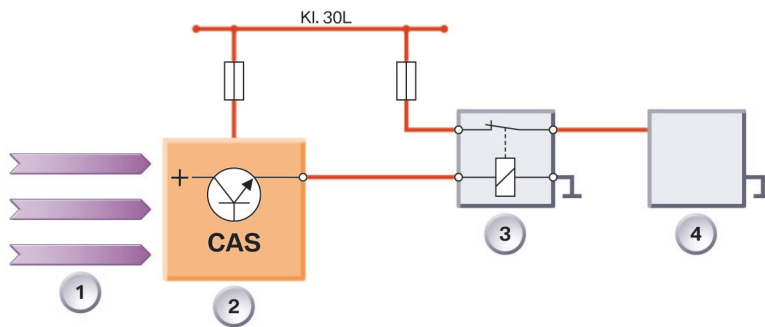

7 - Terminal 30g activation

Index	Explanation	Index	Explanation
1	Input signals, terminal 30g "ON/OFF"	4	Load/consumer
2	CAS (Car Access System)	KI. 30L	Terminal 30, load
3	Terminal 30g relay		

### Switch-on and switch-off conditions of terminal 30 g relay

The switch-on conditions are:

- Unlock vehicle
- Terminal R "ON"
- Auto-remote closing via remote control
- Status change of door contacts or of rear lid contact
- Telephone wake-up line for telematic services
- Service application

The switch-off conditions are:

- 60 minutes after terminal R "OFF"
- Service application

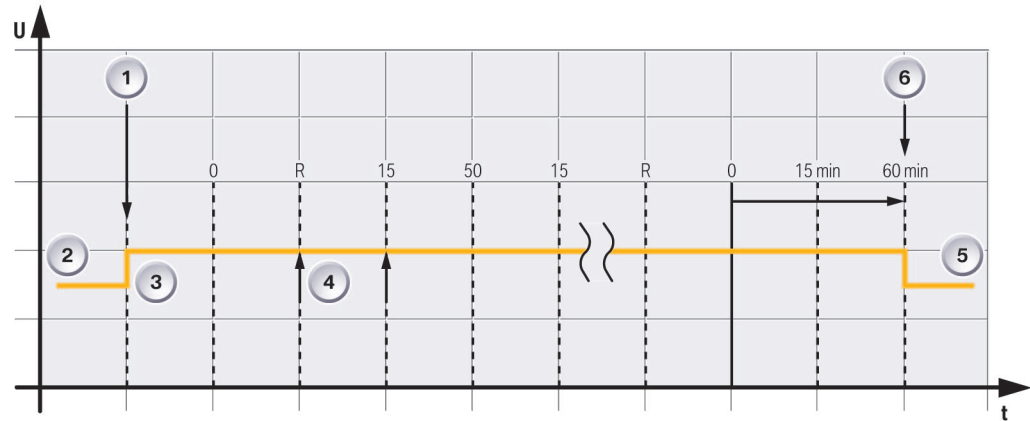

TE04-5583

8 - Terminal 30g switch-on/switch-off conditions

Index	Explanation	Index	Explanation
1	Terminal 30 g relay "ON"	4	Terminal R "ON"
2	OFF	5	OFF
3	ON	6	Terminal 30 g relay "OFF"

The terminal 30 g switch-off procedure disconnects various electrical loads/consumers in a defined manner from the vehicle electrical system. This happens approx. 60 minutes after terminal R "OFF." The deactivated loads/consumers are activated again together with terminal 30g "ON."

The following loads/consumers are deactivated:

- Centre console switch centre
- Rain and driving lights sensor
- Controller
- Central information display
- Slide/tilt sunroof
- Tyre pressure control
- Satellite radio
- TOP HiFi amplifier
- Telephone
- Head-up display
- Active cruise control
- Electronic transmission control
- Dynamic Stability Control
- Adaptive directional headlights

### Service mode

The BMW diagnosis system can be used to place the vehicle in sleep mode in the workshop within 5 secs. by means of the Power Down command.

This is necessary in order to carry out a quick and continuous closed-circuit current without waiting for the normal deactivation time to elapse (60 mins.).

## Micro-power module with bistable relay

As with the terminal 30g relay, the micro-power module enables a defined deactivation of loads/consumers in the event of a fault, i.e. excessive closed-circuit current.

Deactivation only takes place with the vehicle at rest when a fault occurs in the communication area.

The following faults trigger deactivation:

- Excessive closed-circuit current in the event of a critical SoC
- Number of K-CAN wake-up procedures exceeded

- Undervoltage
- Vehicle does not go into sleep mode.

### Integration in the K-CAN

The micro-power module is connected to the K-CAN.

The micro-power module detects 3 operating states, namely normal mode, sleep mode and service mode.

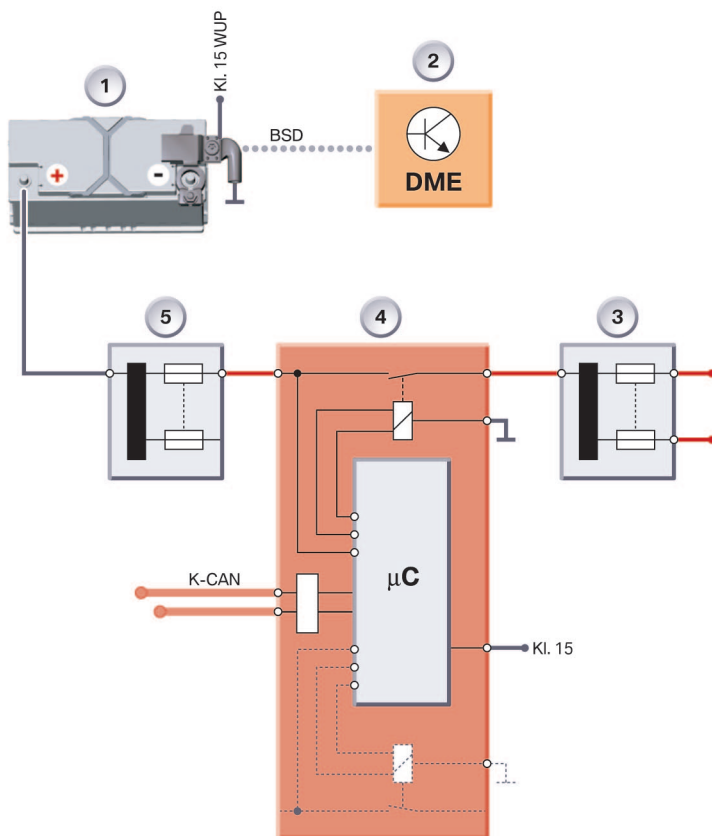

TE04-5598

9 - Block diagram, micro-power module

Index	Explanation	Index	Explanation
1	Battery	BSD	Bit-serial data interface
2	DME (Digital Motor Electronics)	K-CAN	Body CAN
3	Front power distribution box	KI. 15	Terminal 15
4	Micro-power module	KI. 15 W Up	Terminal 15, wake-up
5	Rear power distribution box		

### **Normal mode:**

All functions of the micro-power module are available in normal mode.

The micro-power module switches OFF/ON the voltage supply to all the loads/consumers involved in communication.

These loads/consumers are:

- M-ASK (multi-audio system controller)
- CCC (Car Communication Computer)
- CDC (Compact Disc Changer)
- DVD changer
- Japan navigation

The supply voltage is switched on and off by means of a bistable relay. The relay is set to "ON" when it leaves the factory. The switch-on condition has priority over the switch-off condition.

The switch-on conditions are:

- Creation for the first time of the supply voltage at the micro-power module "First Switch to Power"
- Locking/unlocking
- Terminal R "ON"
- Terminal R 15 "ON"
- Changes in status of door contacts or of boot lid contact
- Bus activity

The switch-off conditions are:

- Excessive closed-circuit current in the event of a critical SoC
- Signal "Stationary loads/consumers OFF" by DME/DDE
- Undervoltage < 9 V for a time period > 60 seconds
- Number of K-CAN wake-up procedures exceeded
- Bus activity after 60 minutes in spite of the vehicle having stopped, i.e. the vehicle cannot go into sleep mode after terminal R "OFF".

The relay disconnects the loads/consumers from the vehicle electrical system with a 5-minute delay. This delay allows the respective loads/consumers to sign off from the electrical system. The switch-off procedure is interrupted if a switch-on condition applies during this 5-minute period.

Special cases for switch-off conditions:

- The loads/consumers have already been disconnected from the vehicle electrical system
- The vehicle door is opened without the vehicle being started
- Bus activity

### **Sleep mode**

The micro-power module goes into sleep mode approx. 1 second after the K-CAN has gone into sleep mode.

The current switching status of the relays is stored before the micro-power module goes into sleep mode.

The micro-power module is woken by the terminal 15 signal via the K-CAN or by activation of terminal 15.

On waking, the switching status of the relay last stored is reestablished.

### **Service mode**

The BMW diagnosis system can be used to place the vehicle in sleep mode in the workshop within 5 secs. by means of the Power Down command.

This is necessary in order to carry out a quick and continuous closed-circuit current test.

## Energy management with junction box

The energy management functions in vehicles with junction boxes are executed in the power management system of the DME/DDE. There are two different systems, depending on the vehicle equipment specifications:

- BPM (Basic Power Management)
- APM (Advanced Power Management)

The BPM is identical to the basic energy management in other BMW vehicles. The BPM is installed without a IBS.

There are two different operating modes:

- Vehicle operation (terminal 15)
- Vehicle stationary (terminal R and terminal 30)

### Basic power management

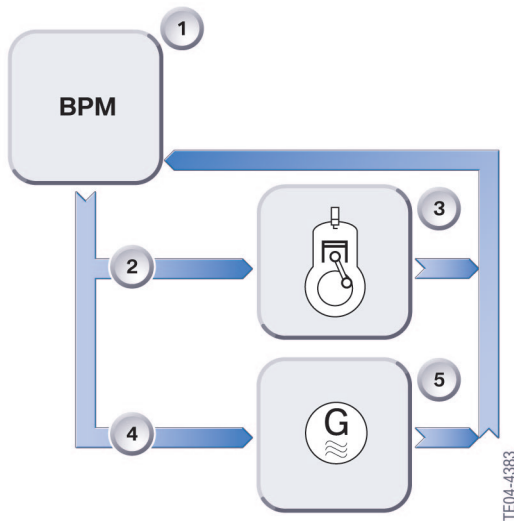

10 - Basic power management

Index	Explanation
1	Basic power management
2	Idle speed increase
3	Combustion engine
4	Charging voltage specification
5	Alternator

This variant features only idle speed increase and charging voltage specification.

#### Idle speed increase

If current is drawn from the battery despite the alternator operating at maximum, the idle speed is increased here by 200 rpm on vehicles with petrol/gasoline engines.

The higher transmission ratio between the engine and the alternator renders this intervention unnecessary in the case of diesel engine variants.

#### BPM charging voltage specification

The BPM controls the voltage at the alternator depending on the temperature. The input variable here is the outside temperature. This input variable is used in the power management system to calculate the battery temperature.

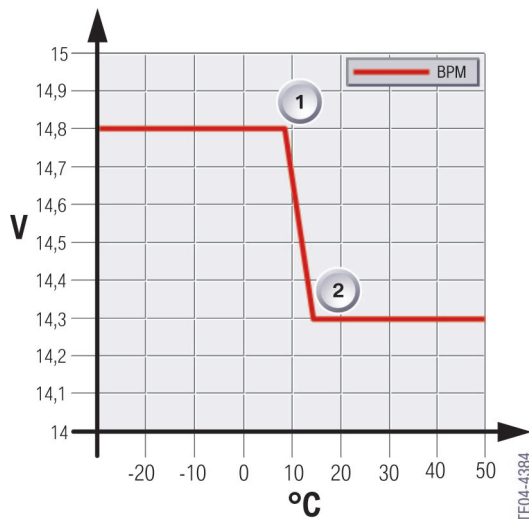

11 - Charging voltage increase

Index	Explanation
1	Normal charging voltage
2	Increased charging voltage

## APM (Advanced Power Management)

The APM is used if an IBS is installed.

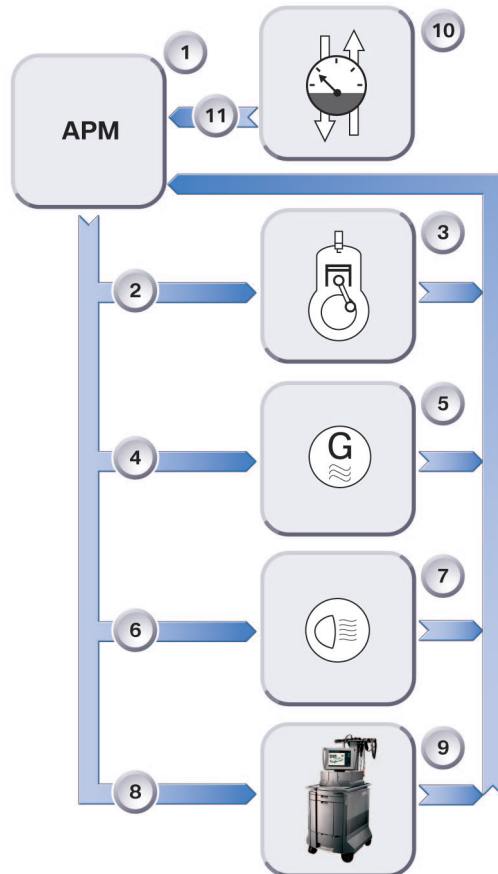

Index	Explanation
1	Advanced power management
2	Idle speed increase
3	Combustion engine
4	Charging voltage specification
5	Alternator
6	Consumption reduction
7	Load/consumer
8	Electrical system and battery diagnosis
9	BMW diagnosis system
10	Intelligent battery sensor
11	Battery data

The following functions are integrated in both management systems:

- Idle speed increase
- Charging voltage specification

The following additional functions are integrated in advanced power management only:

- Electric load reduction
- Vehicle systems diagnosis
- Battery diagnosis

As is the case with energy management with the micro-power module, an IBS (intelligent battery sensor) is installed for APM.

12 - Advanced power management

TE04-4385



### APM charging voltage specification

With APM the outside temperature is not used to calculate the battery temperature. Here the battery temperature is measured directly with the IBS.

This information is sent via the BSD line to the alternator.

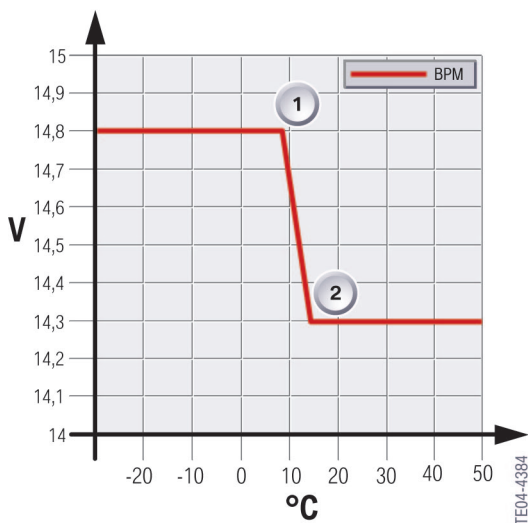

13 - Charging voltage increase

Index	Explanation
1	Normal charging voltage
2	Increased charging voltage

### Electric load reduction

In vehicles with APM, in addition to increasing the idle speed and the charging voltage specification, it is also possible to deactivate various loads/consumers to reduce power consumption.

Load/consumer deactivation is performed under the following two conditions:

- State of battery charge in critical range
- Alternator fully utilized

### Electric auxiliary heater

Because the electric auxiliary heater in diesel engine variants at up to 1000 W is classed as one of the loads/consumers with relatively high power, it must be deactivated under certain preconditions.

Deactivation is performed as with energy management with the micro-power module.

## Energy flow

### Current flow during vehicle operation

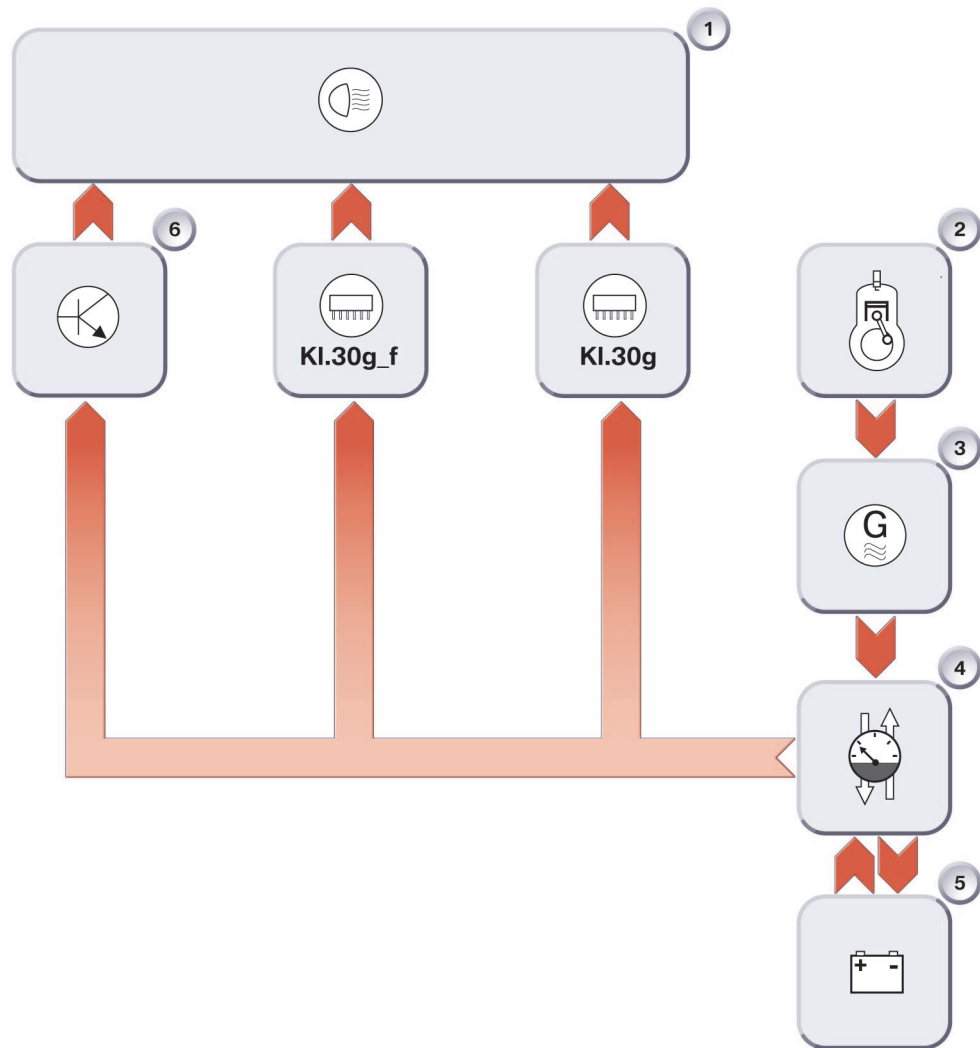

TE04-4387

14 - Current flow during vehicle operation

Index	Explanation	Index	Explanation
1	Load/consumer	4	Intelligent battery sensor
2	Drive motor	5	Vehicle battery
3	Alternator	6	Control units

The electrical loads/consumers receive their power supply mainly via terminal 30g and via terminal 30g-f. Certain loads/consumers are also still supplied directly by terminal 30 or by terminal R.

The anti-theft alarm system must still remain active when the ignition is switched off.

The intelligent battery sensor is installed only with APM.

## Information flow

### Control process information

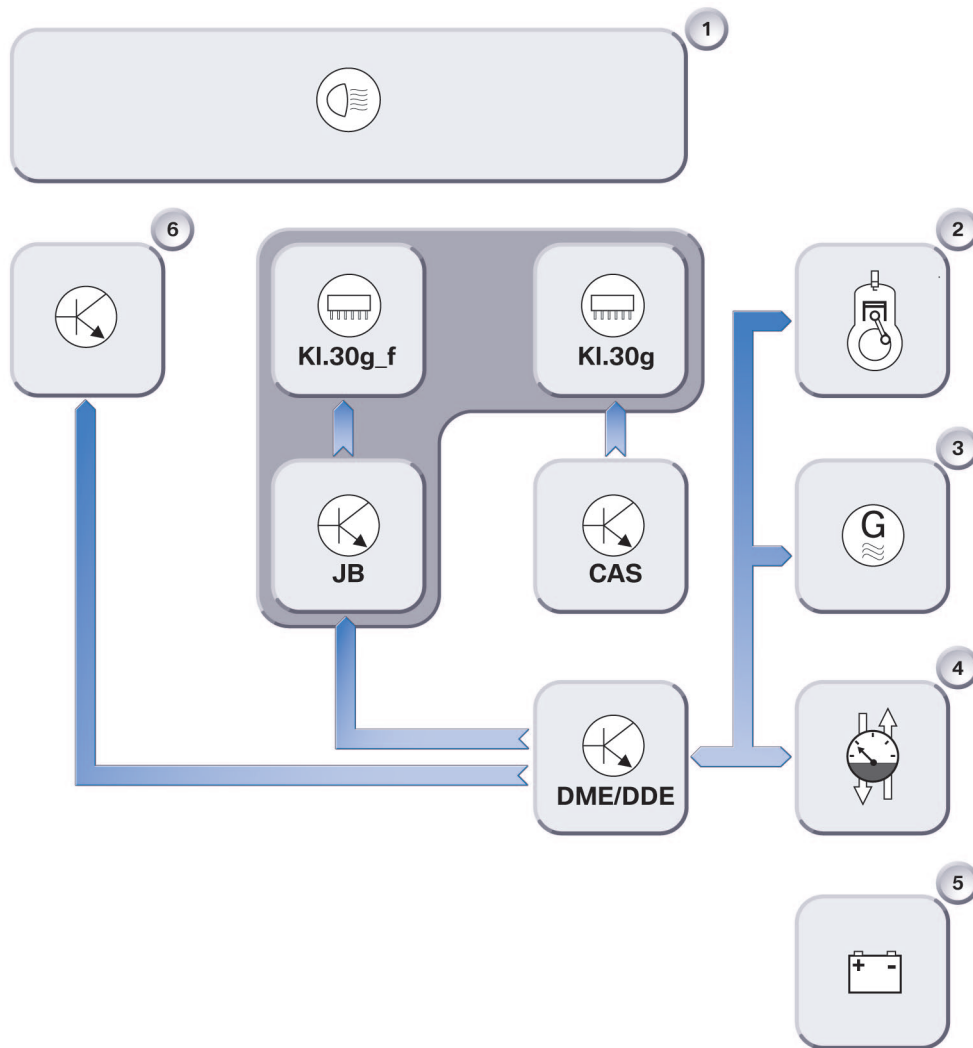

TE04-4389

15 - Control process information

Index	Explanation	Index	Explanation
1	Load/consumer	4	Intelligent battery sensor
2	Drive motor	5	Vehicle battery
3	Alternator	6	Control units

The power management controls the idle speed and the charging voltage specification while the engine is running.

The power intake of electrical loads/consumers with relatively high power consumption is reduced or the loads/consumers are deactivated as required.

Certain loads/consumers can be switched off when the engine is stationary. The loads/consumers are deactivated on a time-controlled basis via the CAS and the terminal 30g relay. The junction box and the terminal 30g-f relay deactivates certain loads/consumers in the event of electrical faults.

## Vehicle stationary (terminal R and terminal 30)

### Stationary loads/consumers

Certain loads/consumers may be active even when the closed-circuit current monitoring facility of the power management is already in operation. This is necessary for various reasons:

- Legally required loads/consumers, e.g. side lights, hazard warning system
- Convenience for the customer, e.g. radio function, telephone

These electric loads must be excluded from the closed-circuit monitoring system in order to avoid misinterpretation in the power management. For this purpose, these electric loads must log in with the power management. In turn, the power management recognizes the activity and accepts the higher power consumption when the systems are deactivated, the corresponding control units log off from the power management.

### Stationary load log-off

The power management in the engine control can send a request to switch off the active electric loads in stationary mode depending on the battery charge status and the start capability limit. As a result, the stationary loads must deactivate their functions irrespective of the terminal status and must reach their closed-circuit current within 5 minutes. Legally required electric loads are excluded from this function.

### Terminal 30g and terminal 30g\_f

Depending on the equipment configuration, the E87 has one or two relays for the purpose

of switching off the power supply to the majority of control units. The terminal 30g relay is always installed. The terminal 30g\_f relay is installed only when one of the following options is ordered:

- M-audio system controller
- Car communication computer

The relays are controlled by following control units:

- Terminal 30g - activation by the CAS
- Terminal 30g\_f - activation by the junction box control unit
  - Events that prevent sleep mode (control units that keep the bus systems constantly active)
  - Invalid wake-up procedures within the bus systems
  - The battery values are constantly read out and evaluated in the engine control unit. This relay is also switched off if the start capability limit of the battery is reached.

### Explanations

Kl. 15	Ignition
R	Radio setting
30	B+
30g	B+ time-dependent
30g_f	B+ fault-dependent

## Terminal 30g relay

### Time-dependent deactivation

The terminal 30g relay switches off the connected electric loads after 30 minutes. The afterrunning time is extended to

60 minutes for a telephone installed in the vehicle. The terminal 30g relay is controlled by the car access system.

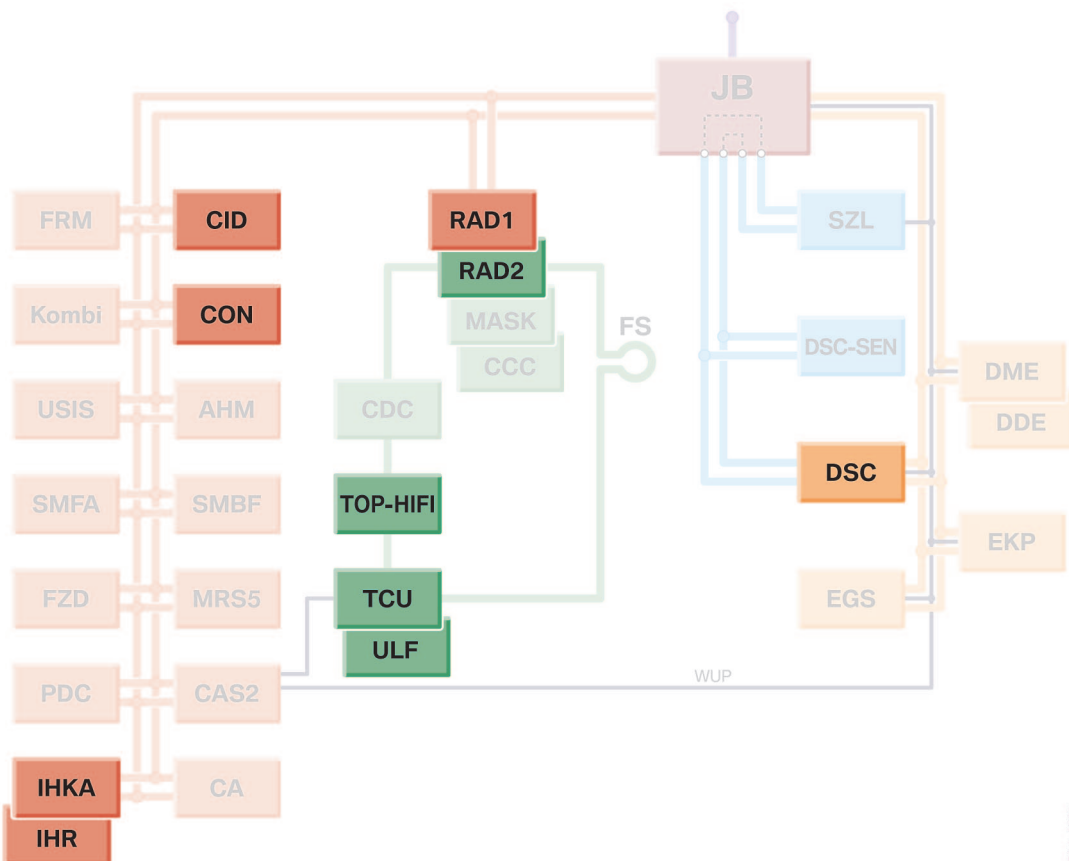

16 - E87 terminal 30g relay

TED4-4391

## Terminal 30g\_f relay

### Fault-dependent deactivation

The terminal 30g\_f relay is controlled by the junction box control unit and switches off the connected electric loads if a fault occurs. The

terminal 30g\_f relay is a bistable relay. Each switching status is retained even when no power is applied.

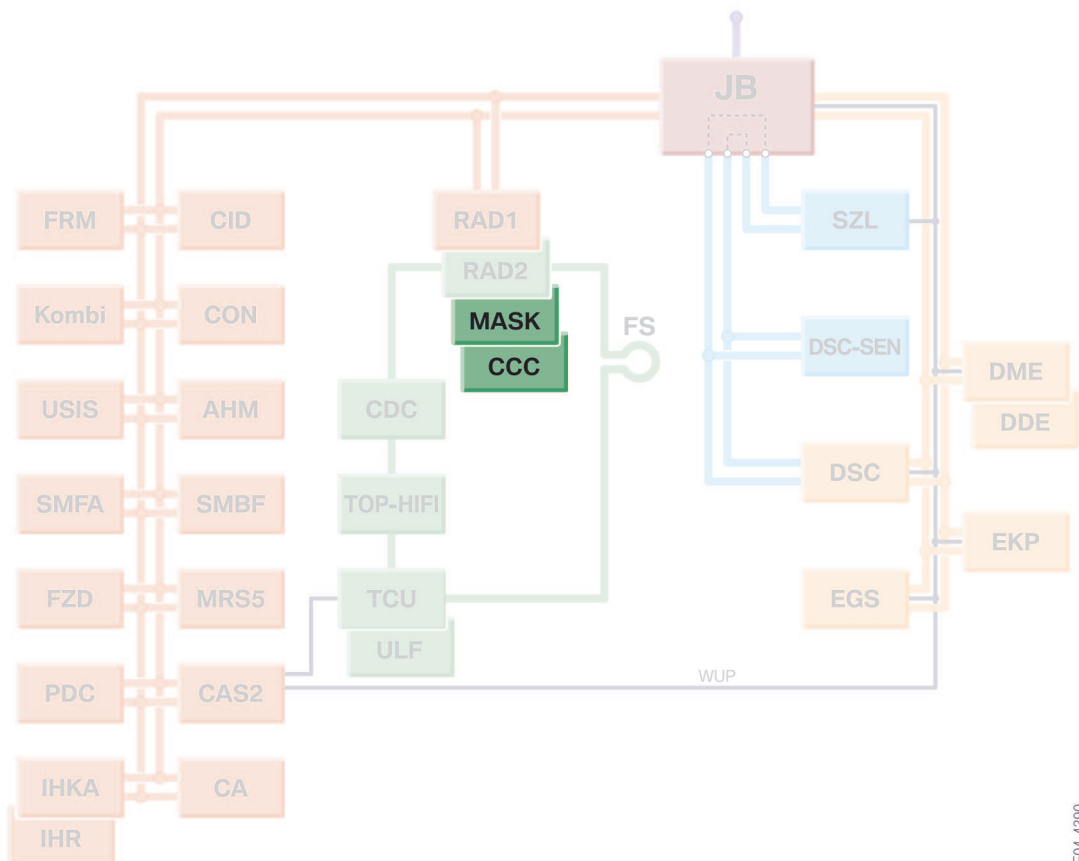

17 - E87 terminal 30g\_f relay

### Terminal 30g\_f relay switch-on and off conditions

The terminal 30g\_f relay is switched on and off under the following conditions.

Terminal 30g\_f ON at:

- Unlock vehicle or
- Terminal R or
- Change in status\_contact\_rear\_hatch or change in status\_door\_contact\_FAT/BFT/FATH/BFTH

Terminal 30g\_f OFF at

- Receiving the "Signal OFF" message. Terminal 30g\_f relay is switched off after 5 minutes.

- Bus activity for 60 minutes with no switch-on condition applicable.
- Vehicle is woken 30 times with no switch-on condition applicable.

The terminal 30g\_f relay is a bistable relay and is always switched on under normal conditions. It switches off the connected electric loads only in the case of fault. Once the terminal 30g\_f relay has been switched off, one of the switch-on conditions is necessary in order to switch it on again.

## Terminal 30

### Continuous positive

As before, various electric loads are connected directly to terminal 30.

The PDC control unit is connected to terminal 15.

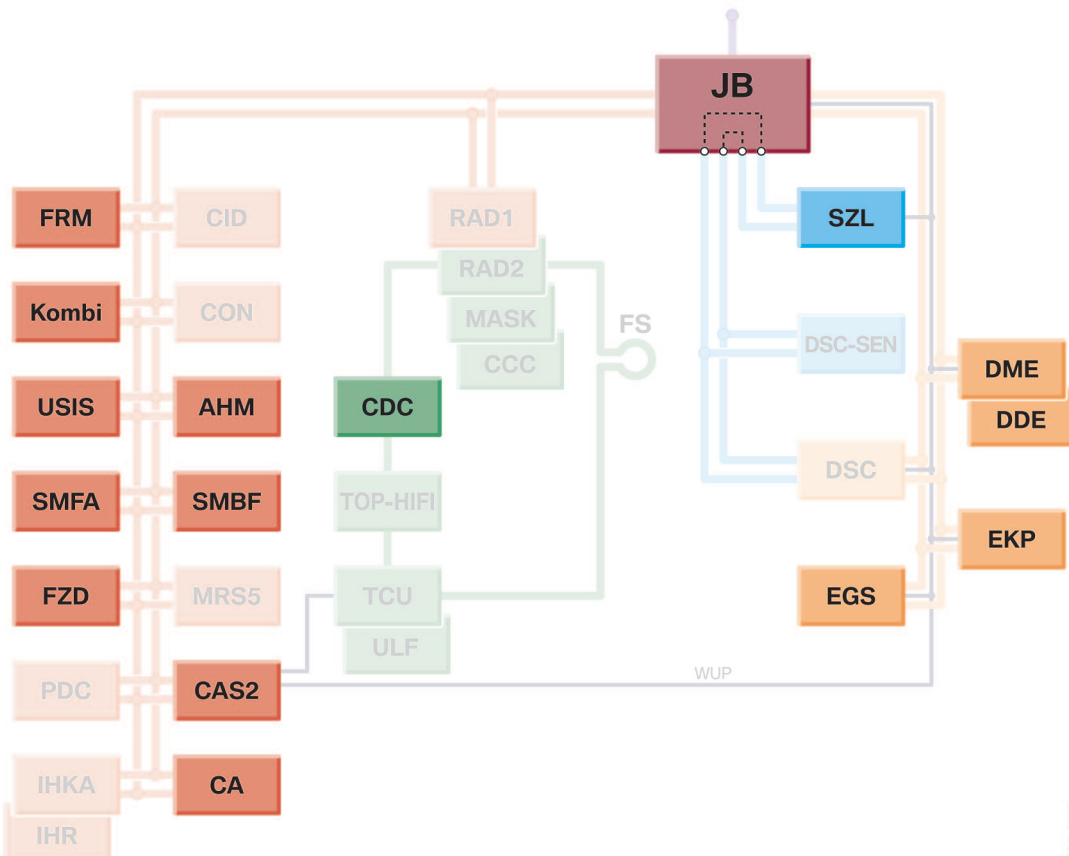

18 - E87 terminal 30

TE04-4392

General measures:

The terminals load shut-down and the interior lighting are switched off as a general measure when the vehicle is in stationary mode. This occurs only when the vehicle is locked and

secured. In this case, these electric loads are switched off immediately after the vehicle is secured. This measure affects the following electric loads:

Load/consumer	Terminal
Interior lights (front and rear)	Interior lights
Footwell lighting (front and rear)	Interior lights
Reading light (front and rear)	Load/consumer deactivation
Vanity mirror light	Load/consumer deactivation





# System components

## Energy management

### Components, energy management, power module

Energy management is controlled by the power module in the BMW E65/E66/E67 vehicle types. In conjunction with the power

module, a battery switch is also installed in the luggage compartment of the E65/E66/E67.

#### Power module

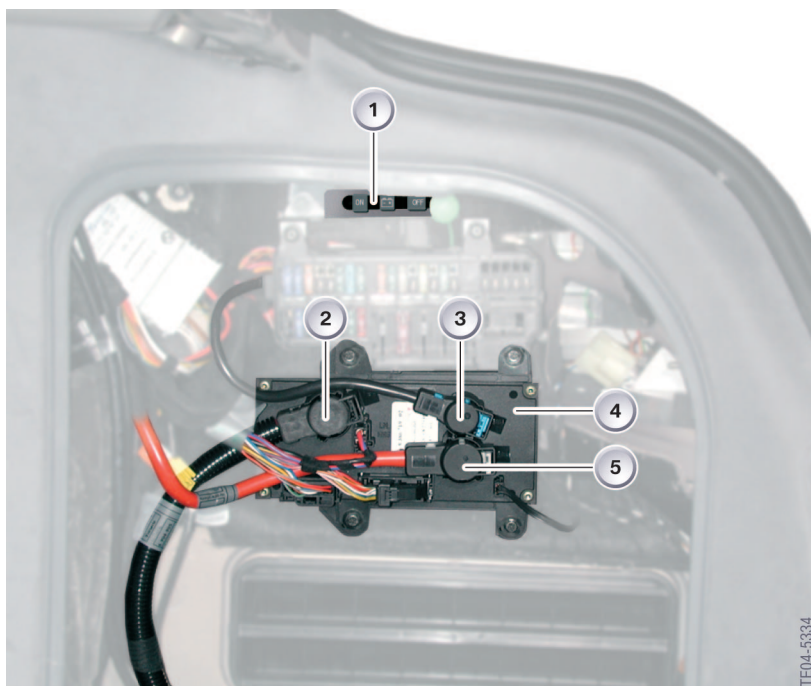

1 - Power module

Index	Explanation	Index	Explanation
1	Battery switch	4	Power module
2	Battery positive cable	5	Terminal 30B
3	Terminal 30U		

The function of the power module is to safeguard the state of charge of the battery while the vehicle is both moving and stationary and in the event of electrical faults in the vehicle electrical system.

The components of the power module are:

- Electronic battery master switch
  - Consisting of four MOSFET output stages
- High-current sockets
- Inputs
- Outputs via the electronic battery master switch
- Direct outputs
- Fuses
- Electronic control

---

## Electronic battery master switch

The electronic battery master switch in the power module is made up of 4 MOSFET (Metal Oxide Semiconductor Field Effect Transistor) output stages. It connects the terminal 30 input with the terminal 30 U and terminal 30 B outputs in the power module.

The following functions are switched via the power module, depending on the setting of

the battery switch in the luggage compartment:

- Distribution mode
- Closed-circuit current monitoring
- Electronic fuse
- Automatic electrical system disconnection

---

## High-current sockets

The high-current sockets are installed at the terminal 30 input and the terminal 30 U and terminal 30 B outputs.

These contacts withstand short-term peak currents up to 220 A.

The advantages of these high-current sockets are:

- Continuous load of up to 100 A possible
- Long-term uniform current transfer
- Low voltage drop with high heating
- Constantly high spring properties
- Self-cleaning of contacts through permitted movements

## Inputs and outputs

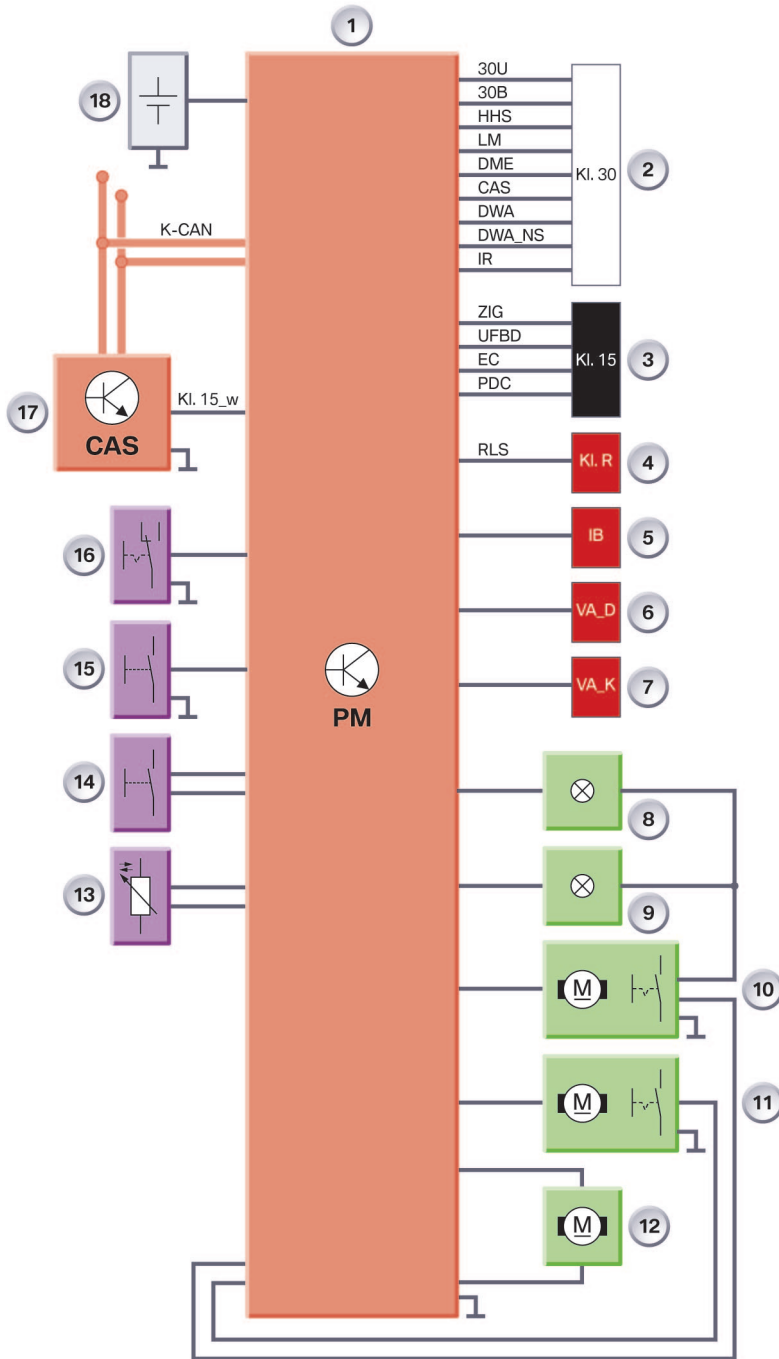

2 - Inputs and outputs, power module

Index	Explanation	Index	Explanation
1	Power module	10	Soft Close Automatic
2	Terminal 30	11	Central locking
3	Terminal 15	12	Fuel tank flap
4	Terminal R	13	Temperature sensor
5	Interior lights	14	Open rear lid button
6	VA_D Load/consumer deactivation, roof area	15	Interior lights switch
7	VA_K Load/consumer deactivation, body area	16	Battery switch
8	Luggage compartment light	17	CAS terminal 15_w
9	Rear lid warning light	18	Battery

## Inputs

### Terminal 30

The battery positive terminal is directly connected to the load input of the power module.

### Battery switch

The battery switch permits selection between "ON" (closed-circuit current monitoring) and "OFF" (distribution mode). The battery switch is located above the power module in the luggage compartment.

### Interior lights button

This button controls the interior lights and is located on the front interior lights unit. It can be selected between the states "Automatic control" ON and OFF.

### Button for opening rear lid from outside (TOEHK)

The button on the outside of the rear lid is used to open the rear lid itself.

### Contact, central locking

The contact in the central-locking motor lock in the rear lid serves to unlock the central-locking motor in the rear lid and to synchronize the SCA (Soft Close Automatic).

### Contact, external SCA

SCA motor, luggage compartment lighting, monitoring of DWA (anti-theft alarm system) and rear lid warning light.

### Terminal 15\_W

The signal comes from the CAS (Car Access System) and wakes the power module.

### Sensor, battery temperature

The sensor measures the temperature of the battery directly at the negative terminal.

### K-CAN peripherals

Permit communication with the other electronic control units.

---

## Outputs via the electronic battery master switch

### Terminal 30U

Supplies the fuse carrier in the luggage compartment.

### Terminal 30B

Supplies the fuse carrier in the glovebox.

---

## Direct outputs

Direct outputs are led out separately from the power module, to which the following loads/consumers are connected:

- HHS (Heated rear window)
- LSZ (Light switch centre)
- CAS (Car Access System)
- DWA (Anti-theft alarm system)
- NS (Emergency power siren)
- IR (Infrared remote control), country version
- ZIG (Cigarette lighter), country version
- UFBD (Universal remote control) country version
- EC (Electrochrome interior rear-view mirror)
- PDC (Park Distance Control)
- RLS (Rain/Light Sensor)
- IB (Interior lighting)
- ZV (Central locking), rear lid
- ZV (Central locking), fuel tank flap
- SCA (Soft Close Automatic), rear lid

---

## Fuses

The outputs of the heated rear window, terminal R and terminal 15 do not have fuses.

The heated rear window and terminals R and 15 are supplied via a circuit-breaker (MOSFET) in the power module.

## Components, energy management, micro-power module

### Micro-power module

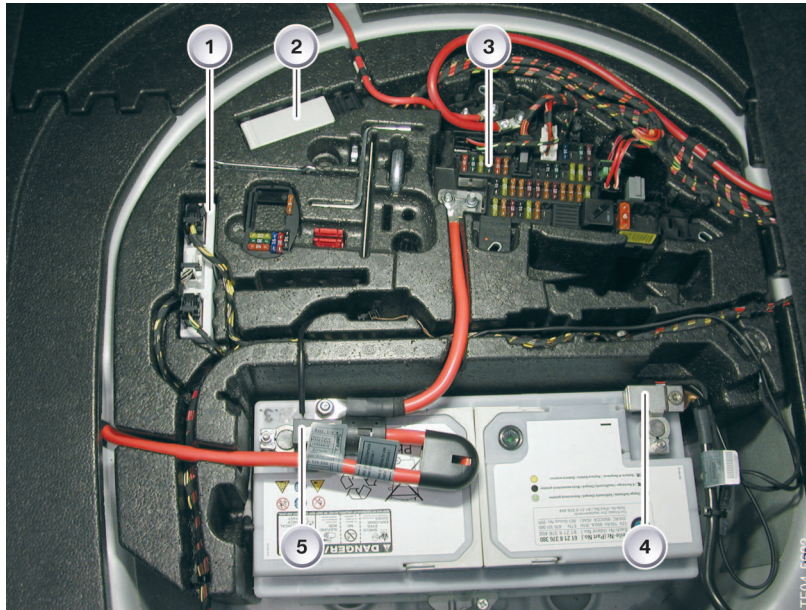

3 - E63 installation location, components, luggage compartment well

Index	Explanation	Index	Explanation
1	Park Distance Control	4	Intelligent battery sensor
2	Micro-power module	5	Safety battery terminal
3	Rear power distribution box		

In the event of a fault, the micro-power module switches off the voltage supply to all the loads/consumers involved in communication.

### Electronic engine management

The DME/DDE accommodates the software for controlling the flows of energy in the vehicle.

The functions of electric power management are:

- Adapting the alternator charging voltage
- Increasing idle speed to increase the alternator power output
- Reducing peak loads to prevent a deficit in the vehicle electrical system
- Deactivating loads/consumers when the start capability limit of the vehicle is reached
- Closed-circuit current diagnosis

## Terminal 30 g relay

The terminal 30 g relay prevents increased closed-circuit current consumption.

The terminal 30 g relay contains the defined deactivation of loads/consumers by the CAS.

The "g" in the terminal designation denotes that terminal 30 g is a switched terminal.

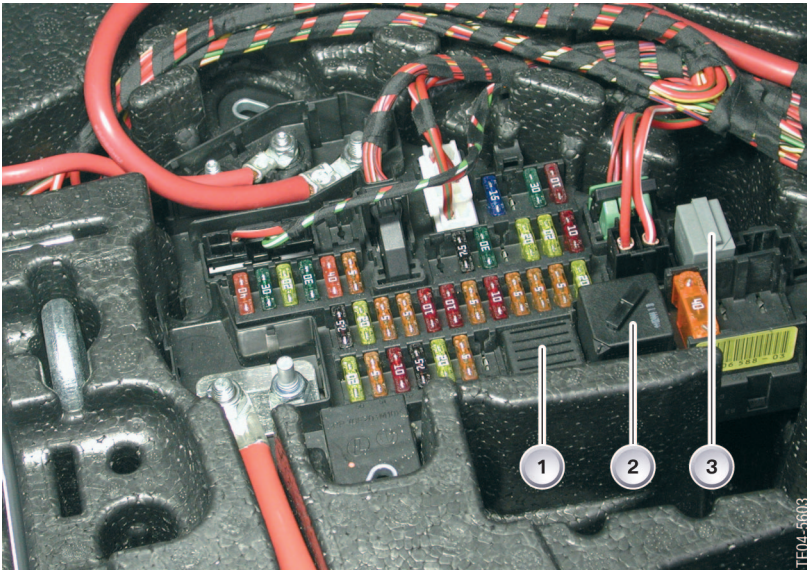

4 - E63 installation location, terminal 30 g relay

Index	Explanation	Index	Explanation
1	Heated rear window relay	3	Terminal 15 relay soldered
2	Terminal 30 g relay		



## Intelligent battery sensor

The intelligent battery sensor is a vital component of the energy management system in BMW vehicles.

The IBS continually measures the following:

- Battery terminal voltage

- Battery charge/discharge current
- Battery acid temperature

This information is made available to the power management system in the DME/DDE.

## Installation location, intelligent battery sensor

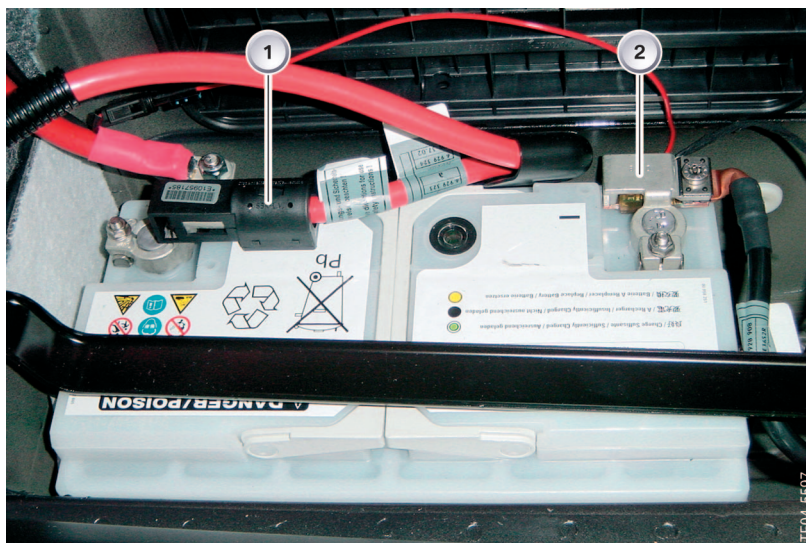

5 - Installation location, intelligent battery sensor

Index	Explanation
1	Safety battery terminal
2	Intelligent battery sensor

The IBS is located directly on the battery negative terminal and can thus be used for many BMW vehicle types.

The IBS can withstand temperatures of up to 105 °C and chemical loads and is therefore suitable for installation in both the luggage compartment and the engine compartment.



## Intelligent battery sensor (IBS)

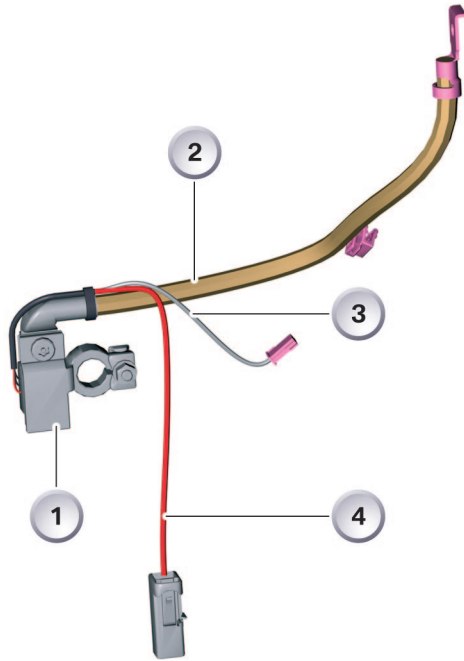

Index	Explanation
-------	-------------

1	Intelligent battery sensor
2	Ground cable
3	Bit-serial data interface (BSD)
4	Connection B+

The intelligent battery sensor (IBS) can be used to determine precisely the "state of charge" (SoC) and the "state of health" (SoH) of the battery.

6 - Intelligent battery sensor

TE04-4562

## IBS design

The IBS consists of mechanical, hardware and software elements. The mechanical part

consists of the battery terminal with ground cable for the negative terminal.

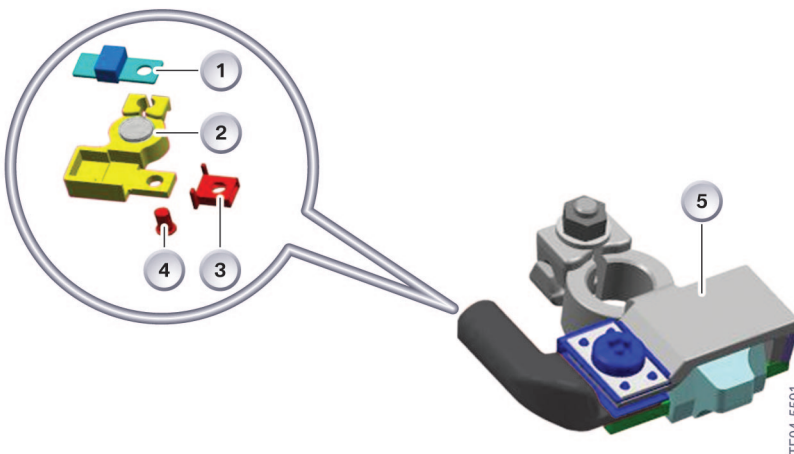

7 - IBS design

TE04-5691

Index	Explanation	Index	Explanation
1	Measuring shunt	4	Screw
2	Pole terminal	5	Intelligent battery sensor
3	Spacer		

### Functions of the mechanical section of the IBS

The functions of the mechanical section are:

- Providing electrical contact of the vehicle body with the negative terminal
- Accommodating the sensor element for current measurement
- Accommodating the hardware
- Providing sufficient thermal contact between the temperature sensor of the hardware and the battery negative terminal
- Providing protection for the sensitive electronic components
- The battery terminal is the ground connection for the IBS

### Measuring shunt design

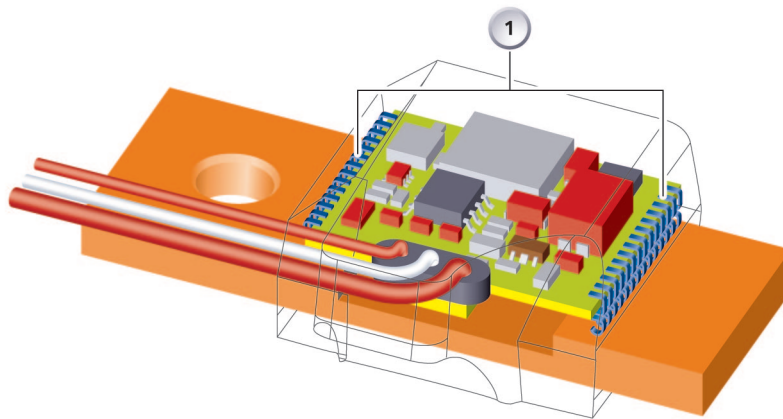

TE04-5336

8 - Measuring shunt

Index	Explanation
1	Spring elements, so-called gull wings

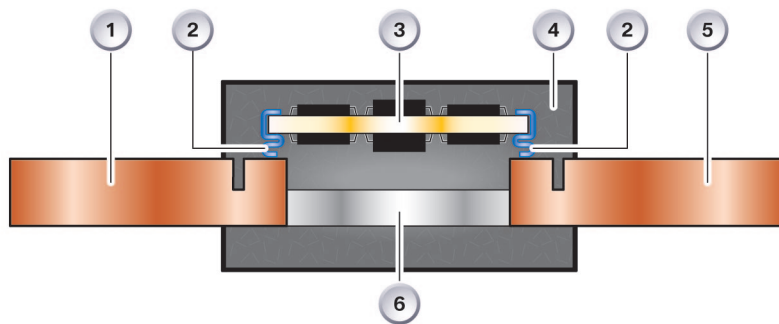

TE04-5592

9 - Measuring shunt design

Index	Explanation	Index	Explanation
1	Copper	4	Extrusion coating
2	Spring elements (gull wings)	5	Copper
3	PCB with electronic evaluation unit	6	Manganin

The functions of the measuring shunt are as follows:

- Shunt for current measurement
- Multi-layer board as electronic circuit including the electronic components.

## Components, energy management with junction box

The energy management system consists of the following components:

- Combustion engine
- Alternator
- Vehicle battery
- Engine management (power management)
- Intelligent battery sensor (depending on equipment)

- Junction box
- Terminal 30g relay
- Terminal 30g\_f relay
- Electrical loads/consumers

The most important components of the energy management system are described in the following.

### Junction box

#### Location of junction box



10 - Location of junction box

The junction box consists of two parts, the distribution box and the junction box control unit. The junction box is installed behind the glovebox beneath the instrument panel.

The terminal 30g and terminal 30g\_f relays are situated in the junction box. The terminal 30g relay is inserted. The terminal 30g\_f relay is located directly on the PCB and is soldered.

## Engine management (power management)

The (power management) software for controlling the energy balance is located in the engine management (DME/DDE). Different electrical loads/consumers in the vehicle electrical system are deactivated from this control facility. The power management system issues the commands to the CAS and to the junction box to deactivate the terminal 30g and terminal 30g\_f relays. The power management is additionally responsible for evaluating and storing the IBS data.



TE04-5923

11 - Engine management with integrated power management

# Service information

## Energy management

### Information

#### E46 closed-circuit current measurement

For a closed-circuit current measurement on the vehicle, it is necessary to place the module specifically in sleep mode with the "Go to Sleep" diagnosis telegram. This deletes the run-on times for the interior lights and load/consumer deactivation and the module then goes immediately into sleep mode. If this

telegram is received for a second time within a period of 1 minute, the remote control central locking function is disabled for a further 2 minutes. The "Go to Sleep" telegram is only accepted when terminal R is off and no power window or central locking confirmations are running.

#### E87 closed-circuit current

The closed-circuit current on the E87 is:

- Approx. 9 mA in basic version
- Approx. 21 mA at maximum equipment configuration

A check control message is sent as from a closed-circuit current value of 80 mA (increased battery discharge when the vehicle is stationary).

The following diagram shows a typical closed-circuit current progression in the E87 in connection with the various operating modes in the vehicle electrical system. The actual current values change depending on the vehicle equipment specification.

VA switches off immediately when the vehicle is double-locked. In all other terminal statuses, terminal VA is switched off after an afterrunning time of 16 minutes. It is activated by the footwell module.

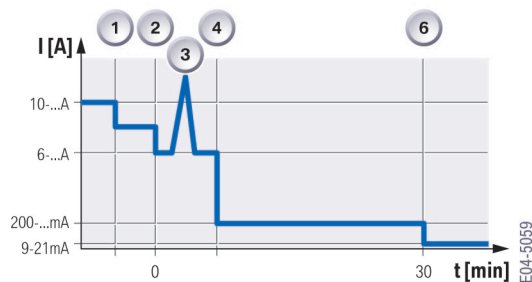

1 - Typical closed-circuit current progression with E87 vehicle secured

The VA terminal (load/consumer deactivation, e.g. reading light and vanity mirror light) is switched off as a function of the terminal status.

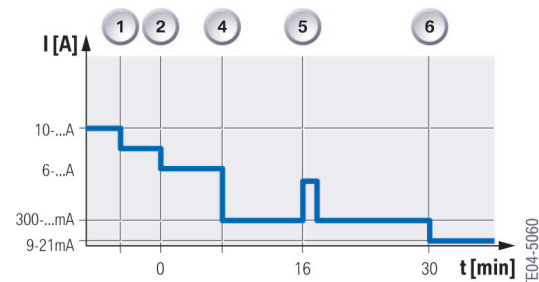

2 - Typical closed-circuit progression with E87 vehicle not secured

Index	Explanation
1	Terminal 15 OFF
2	Terminal R OFF
3	Vehicle is double-locked
4	Start of bus rest phase
5	Load/consumer deactivation after 16 minutes
6	Terminal 30 g OFF (30 without or 60 mins. with telephone)

---

## E65 diagnosis

All the inputs and outputs which are part of the power module can be checked in diagnosis to ascertain their status.

The outputs can also be activated by means of component activation and power consumption displayed.

The following states can be read out:

- Present alternator current
- Present battery current
- Present vehicle electrical system current

- Present load/consumer current draw
- Charge balance
- State of battery charge
- Battery temperature

All electronic fuses and the electronic battery master switch are monitored for short or open circuits.

In the event of a fault, a corresponding entry is made in the power module's fault memory and if necessary a Check Control message is issued.

---

## Service functions, power module

### Power Down command

This function can be used to place electronic control units in sleep mode. It is possible to select between:

1. All control units
2. All control units without power module

The battery switch must be set to "ON" here. On the second Power Down command the battery current is measured and can then be displayed.

### Battery replacement

This function is used to indicate a battery replacement to the power module. The following actions are performed here:

- The battery capacity is set to 80 %.

- The current kilometre reading/mileage is stored.
- The stored battery statistic values (current, voltage, state of battery charge) are deleted.
- The stored temperature statistic values are deleted.

 The kilometre readings/mileages of the last seven battery changes can be read out in the information memory. ◀

### Transport mode

This function can also be activated in the service function. Distribution mode is activated without the battery switch being repositioned to "OFF". However some loads/consumers (radio, TV, interior lights, power windows except on the driver's side) are also permanently deactivated.

---

## Service information on micro-power module

A fault code is stored in the fault memory when the micro-power module disconnects the electrical loads/consumers from the vehicle electrical system.

The following faults can be read out:

- Terminal 15 fault
- Deactivation with information on the switch-off condition. The information on the switch-off condition is stored in the information memory
- Undervoltage
- Contact fault of relay contacts

---

## Intelligent battery sensor

### Service information on the IBS

The IBS is very sensitive to mechanical stress and strain. It must therefore not be changed. The ground cable also serves as a heat dissipater for the IBS.

The following instructions must be observed in service:

- Do not introduce additional connections at the battery negative terminal.
- Do not use force when disconnecting the pole shoe from the battery.
- Do not apply any force under the IBS to lever off the pole shoe.
- Do not use IBS connections as levers.
- Only work with torque wrenches specified in the repair instructions.
- Do not release or tighten the sensor screw.

A fault code is stored in the DME/DDE fault memory if the IBS is faulty. The DME/DDE

adopts a substitute value and goes into IBS emergency mode. IBS emergency mode increases the idle speed in order to sufficiently charge the battery.

The vehicle can no longer be woken in the event of the IBS shorting to ground.

The vehicle no longer goes into sleep mode in the event of the IBS shorting to positive.

The software of the DME/DDE and that of the IBS must match.

### Diagnosis information on the IBS

Diagnosis comprises:

- IBS self-diagnosis
- Voltage measurement
- Current measurement
- Terminal 15 wake-up diagnosis
- IBS system faults

---

## E87 diagnosis information

The control units for the engine management and junction box provide various information for the purpose of realizing effective diagnosis. Information relating to the vehicle battery is stored in the engine management (engine control) system. I

nformation on the functional sequences in the various bus systems is stored in the junction box. The BMW diagnosis system can access and evaluate this information.

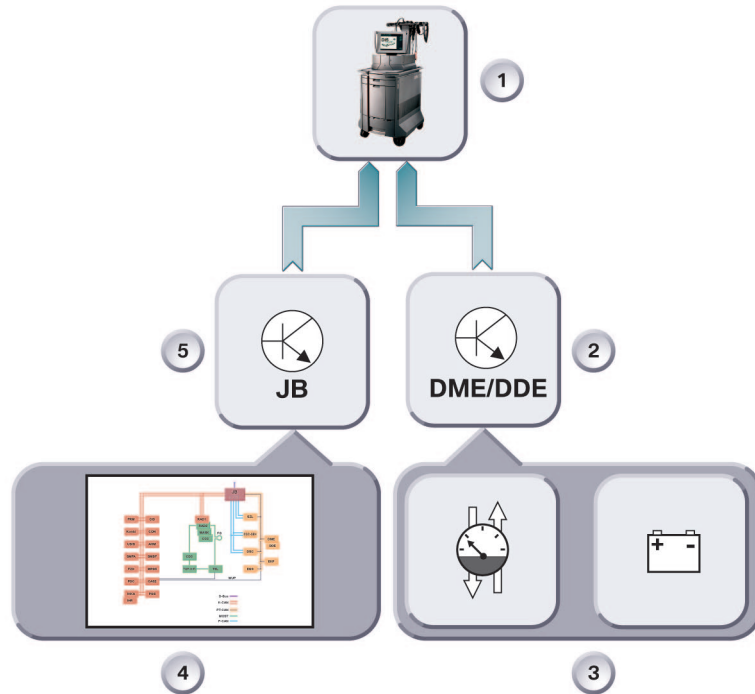

3 - Diagnosis

TE04-4388

Index	Explanation	Index	Explanation
1	BMW diagnosis system	4	Bus systems
2	Engine management	5	Junction box control unit
3	Vehicle battery with IBS	6	



# Summary

## Power Supply/Energy Management

### All topics reiterated in brief

The most important information pertaining to the power supply and energy management is summarized in the following text. This list outlines the main points in concise form and

provides the opportunity of rechecking the most important facts provided in this Participant's Manual.

---

### Power supply

The power supply assumes a specific role in BMW vehicles. Different batteries are installed (lead-calcium and AGM), depending on the equipment specification and the requirements. If the vehicle electrical system is subject to particular load (many stationary loads/consumers), the deep-cycle-resistant AGM battery, which is resistant to exhaustive discharge, is used.

The power supply in BMW vehicles is characterized by several power distribution boxes. The distribution boxes are located in the luggage compartment, in the vehicle

interior at front right and sometimes in the engine compartment.

Several different battery cables (copper, aluminium) are used in BMW vehicles. Certain vehicles have battery cables which are routed along the underbody and monitored for short-circuiting.

The ground points are another important aspect of the power supply in BMW vehicles, particularly in vehicles with reduced-weight aluminium front ends.

The safety battery terminal represents a further innovation in BMW vehicles.

---

### Energy management

An energy management system is used to ensure a proper energy balance in the electrical systems of BMW vehicles.

Different energy management systems are used in BMW vehicles. The most important system is the power management software located in the DME/DDE engine management system. An alternator with a BSD interface is also required. This delivers the simplest system, basic energy management, as used in vehicles with V8 engines in the E53. Different modules are used for defined deactivation of electrical loads/consumers.

An energy management system was used for the first time with a power module in the E65.

The micro-power module is used in conjunction with the intelligent battery sensor in the E60-E64.

In the E87 the junction box assumes the function of deactivating the loads/consumers. The energy management system in the E87 can be configured with or without an IBS.



# Abbreviations

AHM	Trailer module
BSD	Bit-serial data interface
CAS	Car access system
CCC	Car communication computer
CD	Compact disc
CDC	CD changer
DDE	Digital diesel electronics
DME	Digital motor electronics
DWA	Anti-theft alarm system
EGS	Electronic transmission control unit
HHS	Heated rear window
IB	Interior lighting
IBS	Intelligent battery sensor
IHKA	Automatic climate control
IR	Infrared
LSZ	Light switch cluster
M-ASK	Multi-audio system controller
MOSFET	Metal oxide semiconductor field effect transistor
PDC	Park distance control
PTC	Positive temperature coefficient
PWM	Pulse width modulation
RLS	Rain/driving light sensor
SCA	Automatic soft-close function
SH	Auxiliary heating
ZGM	Central gateway module
ZV	Central locking system





